

# Keysight X-Series Signal Analyzers

## N9020A MXA Signal Analyzer

This manual provides documentation for the following Analyzers:

N9020A Option 503 (20 Hz – 3.6 GHz)  
N9020A Option 508 (20 Hz – 8.4 GHz)  
N9020A Option 513 (20 Hz – 13.6 GHz)  
N9020A Option 526 (20 Hz – 26.5 GHz)

Notice: This document contains references to Agilent. Please note that Agilent's Test and Measurement business has become Keysight Technologies. For more information, go to [www.keysight.com](http://www.keysight.com).

# Notices

© Keysight Technologies, Inc.  
2008-2014

No part of this manual may be reproduced in any form or by any means (including electronic storage and retrieval or translation into a foreign language) without prior agreement and written consent from Keysight Technologies, Inc. as governed by United States and international copyright laws.

## Trademark Acknowledgements

Bluetooth®

## Manual Part Number

N9020-90218

## Print Date

December 2014

Supersedes: November 2014

Published in USA

Keysight Technologies  
1400 Fountaingrove Parkway  
Santa Rosa, CA 95403

## Warranty

THE MATERIAL CONTAINED IN THIS DOCUMENT IS PROVIDED "AS IS," AND IS SUBJECT TO BEING CHANGED, WITHOUT NOTICE, IN FUTURE EDITIONS. FURTHER, TO THE MAXIMUM EXTENT PERMITTED BY APPLICABLE LAW, KEYSIGHT DISCLAIMS ALL WARRANTIES, EITHER EXPRESS OR IMPLIED WITH REGARD TO THIS MANUAL AND ANY INFORMATION CONTAINED HEREIN, INCLUDING BUT NOT LIMITED TO THE IMPLIED WARRANTIES OF MERCHANTABILITY AND FITNESS FOR A PARTICULAR PURPOSE. KEYSIGHT SHALL NOT BE LIABLE FOR ERRORS OR FOR INCIDENTAL OR CONSEQUENTIAL DAMAGES IN CONNECTION WITH THE FURNISHING, USE, OR PERFORMANCE OF THIS DOCUMENT OR ANY INFORMATION CONTAINED HEREIN. SHOULD KEYSIGHT AND THE USER HAVE A SEPARATE WRITTEN AGREEMENT WITH WARRANTY TERMS COVERING THE MATERIAL IN THIS DOCUMENT THAT CONFLICT WITH THESE TERMS, THE WARRANTY TERMS IN THE SEPARATE AGREEMENT WILL CONTROL.

## Technology Licenses

The hardware and/or software described in this document are furnished under a license and may be used or copied only in accordance with the terms of such license.

## Restricted Rights Legend

If software is for use in the performance of a U.S. Government prime contract or subcontract, Software is delivered and licensed as "Commercial computer software" as

defined in DFAR 252.227-7014 (June 1995), or as a "commercial item" as defined in FAR 2.101(a) or as "Restricted computer software" as defined in FAR 52.227-19 (June 1987) or any equivalent agency regulation or contract clause. Use, duplication or disclosure of Software is subject to Keysight Technologies' standard commercial license terms, and non-DOD Departments and Agencies of the U.S. Government will receive no greater than Restricted Rights as defined in FAR 52.227-19(c)(1-2) (June 1987). U.S. Government users will receive no greater than Limited Rights as defined in FAR 52.227-14 (June 1987) or DFAR 252.227-7015 (b)(2) (November 1995), as applicable in any technical data.

## Safety Notices

### CAUTION

A **CAUTION** notice denotes a hazard. It calls attention to an operating procedure, practice, or the like that, if not correctly performed or adhered to, could result in damage to the product or loss of important data. Do not proceed beyond a CAUTION notice until the indicated conditions are fully understood and met.

### WARNING

A **WARNING** notice denotes a hazard. It calls attention to an operating procedure, practice, or the like that, if not correctly performed or adhered to, could result in personal injury or death. Do not proceed beyond a WARNING notice until the indicated conditions are fully understood and met.

## Where to Find the Latest Information

Documentation is updated periodically. For the latest information about these products, including instrument software upgrades, application information, and product information, browse to one of the following URLs, according to the name of your product:

<http://www.keysight.com/find/pxa>

<http://www.keysight.com/find/mxa>

<http://www.keysight.com/find/exa>

<http://www.keysight.com/find/cxa>

<http://www.keysight.com/find/mxe>

To receive the latest updates by email, subscribe to Keysight Email Updates at the following URL:

<http://www.keysight.com/find/MyKeysight>

Information on preventing analyzer damage can be found at:

[www.keysight.com/find/PreventingInstrumentRepair](http://www.keysight.com/find/PreventingInstrumentRepair)

## Is your product software up-to-date?

Periodically, Keysight releases software updates to fix known defects and incorporate product enhancements. To search for software updates for your product, go to the Keysight Technical Support website at:

<http://www.keysight.com/find/techsupport>



## Table of Contents

**1. Overview**

What You Will Find in This Chapter .....	13
Keysight MXA Signal Analyzer Overview .....	14
Instrument Option Descriptions .....	15
Signal Analyzer Accessories .....	16
Manual Set on CD-ROM .....	16
50 Ohm Load .....	17
50 Ohm/75 Ohm Minimum Loss Pad .....	17
75 Ohm Matching Transformer .....	17
AC Probe .....	17
AC Probe (Low Frequency) .....	17
Broadband Preamplifiers and Power Amplifiers .....	17
RF and Transient Limiters .....	18
Power Splitters .....	18
Static Safe Accessories .....	18
Before You Start Troubleshooting .....	19
ESD Information .....	21
Protection from Electrostatic Discharge .....	21
Handling of Electronic Components and ESD .....	22
Test Equipment Usage and ESD .....	22
For Additional Information about ESD .....	22
Service Equipment You Will Need .....	23
Calibration Application Software .....	23
Front End Controller Troubleshooting Kit .....	24
USB Keyboard and Mouse .....	25
USB Storage Device .....	25
Required Test Equipment List .....	26
After an Instrument Repair .....	38
Contacting Keysight Technologies .....	39
Instrument Serial Numbers .....	42
How to Return Your Instrument for Service .....	43
Service Order Number .....	43
Original Packaging .....	43
Other Packaging .....	44

**2. Boot Up and Initialization Troubleshooting**

What You Will Find in This Chapter .....	45
Check the Basics .....	46
Instrument Boot Up Process .....	47
Typical instrument boot-up process flow .....	48
Potential Problems During Boot Process .....	51
Yellow Standby LED Does Not Illuminate .....	51
Green Power On LED Does Not Illuminate .....	53

Fan(s) Are Not Operating . . . . .	55
No Agilent Splash Screen Displayed . . . . .	57
Instrument Hangs at the Agilent Splash Screen . . . . .	58
PCI Enumeration Error . . . . .	58
Instrument Cannot Completely Load or Run the Operating System . . . . .	59
Troubleshooting a Blank Display . . . . .	59
Verify LCD Backlight Functionality . . . . .	60
Verify Video Signal Path Integrity . . . . .	63
Video Controller / LCD Troubleshooting . . . . .	63
Initializations Did Not Complete . . . . .	63
Fails an Initial Alignment . . . . .	64
Signal Level Verification . . . . .	70
Signal Level Problem with Input Frequencies < 3.6 GHz . . . . .	70
Signal Level Problem with Input Frequencies > 3.6 GHz . . . . .	71

### 3. Instrument Messages

Introduction . . . . .	73
Event vs. Condition Messages . . . . .	73
Event and Condition Categories . . . . .	74
Event Message Format . . . . .	75
Event Queues . . . . .	76
Advisory Messages . . . . .	78
Event Messages . . . . .	84
-800, Operation Complete Event . . . . .	85
-700, Request Control Event . . . . .	85
-600, User Request Event . . . . .	85
-500, Power on Event . . . . .	85
-400 to -499, Query Errors . . . . .	85
-300 to -399, Device-Specific Errors . . . . .	86
-221 Settings Conflict Errors . . . . .	89
-200 to -299, Execution Errors . . . . .	101
-100 to -199, Command Errors . . . . .	112
0 Error . . . . .	114
Condition Messages . . . . .	115
Condition errors 1 to 99, Calibration . . . . .	115
Condition Errors 101 to 199, Measurement Integrity . . . . .	120
Condition Errors 201 to 299, Signal Integrity . . . . .	123
Condition Errors 301 to 399, Uncalibrated Integrity . . . . .	127
Condition Errors 401 to 499, Power . . . . .	131
Condition Errors 501 to 599, Frequency . . . . .	131
Condition Errors 601 to 699, Error Summaries . . . . .	133
Condition Errors 701 to 799, Operation . . . . .	134
Condition Errors 801 to 899, Temperature . . . . .	135

### 4. RF Section Troubleshooting

What You Will Find in This Chapter .....	137
RF Section Description .....	138
Purpose .....	138
RF Section Theory of Operation .....	142
Troubleshooting .....	146
Quick Check to Verify the Low Band Signal Path .....	146
Troubleshooting a Low Band Problem .....	151
Quick Check to Verify High Band RF Path #1 .....	174
Troubleshooting a High Band Problem .....	178
High Band Preamp (Option P08, P13, P26) .....	204
High Band Mixing Equations .....	204
Microwave Preselector Bypass (Option MPB) .....	205
<b>5. Front End Control Troubleshooting</b>	
What You Will Find in This Chapter .....	207
A15 Front End Control Description .....	208
Purpose .....	208
A15 Front End Control Assembly Troubleshooting .....	212
Verifying Input Attenuator A, Input Attenuator B, Low Band Switch Logic and Power Supplies .....	213
Input Attenuator A Control Logic Verification .....	215
Input Attenuator B Control Logic Verification .....	216
Low Band Switch Control Logic Verification (all except Option 503) .....	216
Preselector Tune Output .....	218
Front End Assembly Control Logic Verification .....	219
Verifying SW1 and SW2 (Option MPB only) .....	221
Oscilloscope Test .....	222
Verifying Aux IF Out, Rear Panel (Option CR3, CRP only) .....	225
Standard Analyzer .....	225
Verifying Option CR3 .....	226
Verifying Option CRP .....	227
<b>6. Analog/Digital IF Troubleshooting</b>	
What You Will Find in This Chapter .....	229
25 MHz BW IF Section .....	232
A2 Analog I.F. Assembly Description .....	232
A2 Analog I.F. Assembly Theory of Operation .....	233
A2 Analog I.F. Troubleshooting .....	236
A3 Digital I.F. Assembly Description .....	243
A3 Digital I.F. Assembly Theory of Operation .....	244
A3 Digital I.F. Troubleshooting .....	246
40 MHz BW IF Section .....	251
A2 Analog IF Assembly Description .....	251
A2 Analog IF Assembly Theory of Operation .....	252
A2 Analog IF Troubleshooting .....	255
A3 Digital IF Assembly Description .....	262
A3 Digital IF Assembly Theory of Operation .....	263

A3 Digital IF Troubleshooting . . . . .	265
≥ 85 MHz BW IF Section. . . . .	273
A25 Wideband Analog IF Assembly Description . . . . .	273
A25 Wideband Analog IF Assembly Theory of Operation . . . . .	273
A25 Wideband Troubleshooting . . . . .	275
A26 140 MHz Wideband Digital IF Troubleshooting . . . . .	278
<b>7. L.O. Synthesizer/Reference Troubleshooting</b>	
What You Will Find in This Chapter . . . . .	279
A14 L.O. Synthesizer Assembly Description . . . . .	280
Purpose . . . . .	280
A14 L.O. Synthesizer Theory of Operation . . . . .	281
Brief Description of the Major Blocks: . . . . .	281
A14 L.O. Synthesizer Troubleshooting . . . . .	282
Verifying the 4800 MHz Input Power & Frequency Stability: . . . . .	283
Verifying the 1st L.O. Output Power: . . . . .	286
A16 Reference Assembly Description . . . . .	290
Purpose . . . . .	290
A16 Reference Assembly Troubleshooting . . . . .	293
Diagnostic LEDs . . . . .	302
<b>8. CPU/Disk Drive Troubleshooting</b>	
What You Will Find in This Chapter . . . . .	305
A4 CPU Description . . . . .	306
Disk Drive . . . . .	306
Front Panel Interface . . . . .	306
Graphics Controller . . . . .	306
Power Supply Control . . . . .	306
Rear Panel Connectivity . . . . .	307
System Memory . . . . .	307
System Processor . . . . .	307
A5 Disk Drive . . . . .	308
Overview . . . . .	309
Troubleshooting software related issues . . . . .	310
Reloading the X-Series Software . . . . .	311
Disk Drive Recovery Process . . . . .	312
Agilent Recovery System . . . . .	312
Using the Instrument Recovery System . . . . .	313
Replacing the instrument disk drive . . . . .	313
<b>9. Power Supply/Midplane Troubleshooting</b>	
What You Will Find in This Chapter . . . . .	315
A6 Power Supply Description . . . . .	316
Purpose . . . . .	316
Power Supply Theory of Operation . . . . .	317
A6 Power Supply Basic Troubleshooting	



(Cover On) . . . . .	322
A7 Midplane Description . . . . .	324
Purpose . . . . .	324
A7 Midplane Assembly Troubleshooting . . . . .	327
<b>10. Front Panel/Motherboard Troubleshooting</b>	
What You Will Find in This Chapter . . . . .	329
A8 Motherboard Description . . . . .	330
Purpose . . . . .	330
A8 Motherboard Troubleshooting . . . . .	331
A1 Front Panel Assembly . . . . .	332
A1A2 Front Panel Interface Board . . . . .	332
A1A3 LCD . . . . .	332
A1A4 LCD Inverter Board/DC-DC Converter . . . . .	332
A1A5 Front Panel USB Interface Board . . . . .	332
Option BBA Description . . . . .	333
A17 LED Board . . . . .	333
A18 BBIQ Interface Board . . . . .	333
A19 BBIQ Main Board . . . . .	334
<b>11. Block Diagrams</b>	
What You Will Find in This Chapter . . . . .	335
Block Diagrams . . . . .	336
RF Lowband Path Block Diagram . . . . .	337
RF Highband Path #1 Block Diagram . . . . .	338
RF Highband Path #2 Block Diagram . . . . .	339
Reference and Synthesizer Block Diagram (Serial Prefix < MY/SG/US5233 without Option B85, B1A, or B1X) . . . . .	340
Reference and Synthesizer Block Diagram (Serial Prefix ≥ MY/SG/US5233 and all with Option B85, B1A, or B1X) . . . . .	341
25 MHz Bandwidth I.F. System Block Diagram . . . . .	342
40 MHz Bandwidth I.F. System Block Diagram . . . . .	343
≥ 85 MHz Bandwidth IF System Block Diagram . . . . .	344
MXA Computer Block Diagram . . . . .	345
BBIQ System Block Diagram . . . . .	346
<b>12. Service and Diagnostics Menus</b>	
Overview . . . . .	347
Controlling Access . . . . .	347
Secure Service Access, Software Versions A.01.xx through A.03.xx . . . . .	348
Summary of Requirements for Service Menu Access, Software Versions A.01.xx through A.03.xx: . . . . .	348
Secure Service Access, Software Version ≥ A.04.00 . . . . .	348
Menus . . . . .	349
Service Key Descriptions . . . . .	353
Timebase . . . . .	353
Corrections . . . . .	354
Band Lock . . . . .	356

---

## Contents

LO Band Lock .....	357
LO Control .....	357
Align .....	358
<b>13. Replaceable Parts</b>	
What You Will Find in This Chapter .....	363
How to Order Parts .....	365
Replaceable Parts .....	366
Hardware .....	382
<b>14. Assembly Replacement Procedures</b>	
What You Will Find in This Chapter .....	435
Before Starting .....	437
Safety .....	437
Tools you will need .....	438
Adjustments Tests after an instrument repair .....	438
Major Assembly Locations .....	439
Instrument Outer Case .....	440
Standard Instrument .....	440
Option PRC .....	442
Top Brace and Reference Bracket .....	445
Removal .....	445
Replacement .....	446
RF Area .....	447
Low Band Switch - Standard Instruments with Serial Number < MY/SG50510001 .....	450
Low Band Switch - Standard Instruments with Serial Number > MY/SG50510001 .....	454
Low Band Switch and Coaxial Switches Options DP2, MPB, B40 .....	458
Attenuators .....	474
YTF Preselector .....	476
RF Front End Assembly .....	479
Removal .....	479
Replacement .....	480
Front End Control Assembly .....	481
Removal .....	481
Replacement .....	483
L.O. Synthesizer Assembly .....	484
Removal .....	484
Replacement .....	484
Rear Panel .....	486
Removal .....	486
Replacement .....	486
Reference Assembly .....	487
Removal (Serial Prefix < MY/SG/US5233	

without Option B85, B1A, or B1X) . . . . .	487
Removal (Serial Prefix $\geq$ MY/SG/US5233 and any with Option B85, B1A, or B1X) . . . . .	488
Replacement . . . . .	491
Power Supply Assembly . . . . .	492
Removal . . . . .	492
Replacement . . . . .	493
CPU Assembly . . . . .	495
Removal . . . . .	495
Replacement . . . . .	497
Disk Drive . . . . .	498
Rear Panel Removable Disk Drive . . . . .	498
Internally Mounted Disk Drive . . . . .	502
Disk Drive Interconnect . . . . .	509
Analog I.F. (AIF)/Digital I.F. (DIF) Assembly . . . . .	511
Removal . . . . .	511
Separate AIF/DIF Assembly . . . . .	514
Replacement . . . . .	515
Wide Band Analog IF and Digital IF Assemblies . . . . .	516
Removal . . . . .	516
Replacement . . . . .	517
Midplane Assembly . . . . .	518
Removal . . . . .	518
Replacement . . . . .	519
Motherboard Assembly . . . . .	521
Removal . . . . .	521
Replacement . . . . .	524
Fan Assembly . . . . .	526
Removal . . . . .	526
Replacement . . . . .	527
Input Connector Assembly . . . . .	529
Removal . . . . .	529
Replacement . . . . .	529
Front Frame Assembly . . . . .	531
Removal . . . . .	531
Replacement . . . . .	532
Bail Handle Removal (Option PRC) . . . . .	533
Front Frame Assembly Components - LCD . . . . .	534
Front Frame Assembly Components - LED . . . . .	541
Option BBA . . . . .	549
<b>15. Post-Repair Procedures</b>	
What You Will Find in This Chapter . . . . .	561
Before Starting . . . . .	561
Post-Repair Procedures . . . . .	562
Additional Tasks . . . . .	567

**16. Functional Tests**

Functional Test Versus Performance Verification ..... 599

Before Performing a Functional Test ..... 600

Test Equipment ..... 601

Displayed Average Noise Level (DANL) ..... 604

    Procedure ..... 604

Frequency Readout Accuracy ..... 607

    Procedure ..... 607

Second Harmonic Distortion (SHD) ..... 609

    Procedure ..... 610

Amplitude Accuracy at 50 MHz ..... 612

    Procedure ..... 613

    Testing Preamp Option (P03, P08, P13, P26) ..... 615

Frequency Response (Flatness) ..... 616

    Procedure ..... 617

Frequency Response (Flatness), Preamp On ..... 620

    Procedure ..... 621

Scale Fidelity ..... 624

    Procedure ..... 625

BBIQ Input Frequency Response (Option BBA only) ..... 628

    Procedure ..... 630

**17. Instrument Software**

What You Will Find in This Chapter ..... 635

Instrument Software Overview ..... 636

Software Licensing ..... 637

Software Updates ..... 638

    Instrument Measurement Application Software ..... 638

    89601 VSA Software ..... 638

# 1 Overview

## What You Will Find in This Chapter

This chapter provides overview information on your spectrum analyzer.

The following sections are found in this chapter:

**Keysight MXA Signal Analyzer Overview on page 14**

**Instrument Option Descriptions on page 15**

**Signal Analyzer Accessories on page 16**

**Before You Start Troubleshooting on page 19**

**ESD Information on page 21**

**Service Equipment You Will Need on page 23**

**After an Instrument Repair on page 38**

**Contacting Keysight Technologies on page 39**

**How to Return Your Instrument for Service on page 43**

## Keysight MXA Signal Analyzer Overview

The Keysight MXA signal analyzer measures and monitors complex RF and microwave signals. The analyzer integrates traditional spectrum measurements with advanced vector signal analysis to optimize speed, accuracy, and dynamic range. The MXA has Windows XP Pro® built in as the operating system, which expands the usability of the analyzer. You will be able to manipulate various file types on your analyzer just like your personal computer. Having a Windows based instrument provides many benefits such as easier file management, built-in Windows based programs such as Internet Explorer, and much more.

The Keysight MXA signal analyzer is readily adaptable to meet changing measurement needs. Optional features, whether hardware or measurement application software, will enable the analyzer to be configured as a comprehensive analytical tool to test communications systems and components.

If customer requirements should change or expand, post sale upgrades can be purchased at any time. Many upgrades require a license key, which is obtained using the Keysight licensing process. If the Keysight Delivery Option is ordered, the entitlement certificate will be emailed to the customer the same day and the license key can be generated and installed in the MXA Signal Analyzer within minutes. Once the license key is entered into the analyzer, the new option is enabled and fully functional.

The service strategy for the MXA is assembly level repair, not component level.

## Instrument Option Descriptions

The MXA signal analyzer has a variety of options and measurement applications that can be installed depending on your application. These options and measurement applications can be purchased and installed at the time of sale or as a post-sale upgrade. In order to find out all the requirements about installing an upgrade into the analyzer, refer to [http://www.keysight.com/find/mxa\\_upgrades](http://www.keysight.com/find/mxa_upgrades)

Description information of Option BBA, Analog Baseband IQ Inputs can be found on [page 333](#).

## Signal Analyzer Accessories

A number of accessories are available from Keysight Technologies to help you configure your analyzer for your specific applications. They can be ordered through your local Keysight Sales and Service Office and are listed below.

### Manual Set on CD-ROM

The entire documentation set excluding the MXA Service Guide is shipped with the instrument on CD-ROM. The documentation that exists on the CD-ROM can also be accessed anytime via the web at [http://www.keysight.com/find/mxa\\_manuals](http://www.keysight.com/find/mxa_manuals).

Each manual is described below:

- Getting Started Guide: Describes analyzer features in detail. In addition, this manual covers unpacking and setting up the analyzer, analyzer features, and information on options and accessories, and what to do if you have a problem.
- Specifications Guide: Documents specifications, safety, and regulatory information.
- Instrument Messages: Includes instrument messages (and suggestions for troubleshooting them).
- Functional Tests: Includes manual functional tests.
- User's/Programmer's References: Multiple manuals which include programming information and SCPI command descriptions for basic spectrum analyzers and for applications such as IQ analyzer, WCDMA, and 802.16 OFDMA.
- Measurement Guides and Programming Examples: Multiple manuals which provide details on how to use catalogs and files, and how to measure various signals for basic spectrum analyzers and for applications such as IQ analyzer, WCDMA, and 802.16 OFDMA.

---

**NOTE** Refer to the front of the CD-ROM, for installation information.

---

**NOTE** Service documentation is **not** included in the standard documentation set. Refer to [http://www.keysight.com/find/mxa\\_upgrades](http://www.keysight.com/find/mxa_upgrades)

---



## 50 Ohm Load

The Keysight 909 series loads come in several models and options providing a variety of frequency ranges and VSWRs. Also, they are available in either 50 ohm or 75 Ohm. Some examples include the:

909A: DC to 18 GHz  
909C: DC to 2 GHz  
909D: DC to 26.5 GHz

## 50 Ohm/75 Ohm Minimum Loss Pad

The Keysight 11852B is a low VSWR minimum loss pad that allows you to make measurements on 75 Ohm devices using an analyzer with a 50 Ohm input. It is effective over a frequency range of dc to 2 GHz.

## 75 Ohm Matching Transformer

The Keysight 11694A allows you to make measurements in 75 Ohm systems using an analyzer with a 50 Ohm input. It is effective over a frequency range of 3 to 500 MHz.

## AC Probe

The Keysight 85024A high frequency probe performs in-circuit measurements without adversely loading the circuit under test. The probe has an input capacitance of 0.7 pF shunted by 1 M $\Omega$  of resistance and operates over a frequency range of 300 kHz to 3 GHz. High probe sensitivity and low distortion levels allow measurements to be made while taking advantage of the full dynamic range of the spectrum analyzer.

## AC Probe (Low Frequency)

The Keysight 41800A low frequency probe has a low input capacitance and a frequency range of 5 Hz to 500 MHz.

## Broadband Preamplifiers and Power Amplifiers

Preamplifiers and power amplifiers can be used with your spectrum analyzer to enhance measurements of very low-level signals.

- The Keysight 8447D preamplifier provides a minimum of 25 dB gain from 100 kHz to 1.3 GHz.
- The Keysight 87405A preamplifier provides a minimum of 22 dB gain from 10 MHz to 3 GHz. (Power is supplied by the probe power output of the analyzer.)
- The Keysight 83006A preamplifier provides a minimum of 26 dB gain from 10 MHz to 26.5 GHz.

- The Keysight 85905A CATV 75 ohm preamplifier provides a minimum of 18 dB gain from 45 MHz to 1 GHz. (Power is supplied by the probe power output of the analyzer.)
- The 11909A low noise preamplifier provides a minimum of 32 dB gain from 9 kHz to 1 GHz and a typical noise figure of 1.8 dB.

## RF and Transient Limiters

The Keysight 11867A and N9355C RF Limiters protect the analyzer input circuits from damage due to high power levels. The 11867A operates over a frequency range of dc to 1800 MHz and begins reflecting signal levels over 1 mW up to 10 W average power and 100 watts peak power. The N9355C microwave limiter (0.01 to 26.5 GHz) guards against input signals over 10 milliwatts up to 1 watt average power.

The Keysight 11947A Transient Limiter protects the analyzer input circuits from damage due to signal transients. It specifically is needed for use with a line impedance stabilization network (LISN). It operates over a frequency range of 9 kHz to 200 MHz, with 10 dB of insertion loss.

## Power Splitters

The Keysight 11667A/B/C power splitters are two-resistor type splitters that provide excellent output SWR, at 50  $\Omega$  impedance. The tracking between the two output arms, over a broad frequency range, allows wideband measurements to be made with a minimum of uncertainty.

11667A: DC to 18 GHz  
11667B: DC to 26.5 GHz  
11667C: DC to 50 GHz

## Static Safe Accessories

9300-1367	Wrist-strap, color black, stainless steel. Four adjustable links and a 7 mm post-type connection.
9300-0980	Wrist-strap cord 1.5 m (5 ft.)

## Before You Start Troubleshooting

Before troubleshooting, complete the following tasks:

- Familiarize yourself with the safety symbols marked on the instrument and read the general safety considerations in the front of this guide.
- Read the ESD information below.
- Familiarize yourself with the troubleshooting information in **Chapter 2, “Boot Up and Initialization Troubleshooting.”**, and how it relates to information on troubleshooting the other assemblies.

**WARNING** These servicing instructions are for use by qualified personnel only. To avoid electrical shock, do not perform any servicing unless you are qualified to do so.

---

**WARNING** The opening of covers or removal of parts is likely to expose dangerous voltages. Disconnect the product from all voltage sources while it is being opened.

---

**WARNING** The detachable power cord is the instrument disconnecting device. It disconnects the mains circuits from the mains supply before other parts of the instrument. The front panel switch is only a standby switch and is not a LINE switch (disconnecting device).

---

**CAUTION** Always position the instrument for easy access to the disconnecting device (detachable power cord).

---

**WARNING** To prevent electrical shock, disconnect the analyzer from mains before cleaning. Use a dry cloth or one slightly dampened with water to clean the external case parts. Do not attempt to clean internally.

---

**WARNING** This is a Safety Class 1 Product (provided with a protective earthing ground incorporated in the power cord). The mains plug shall only be inserted in a socket outlet provided with a protective earth contact.

---

Any interruption of the protective conductor inside or outside of the product is likely to make the product dangerous. Intentional interruption is prohibited.

---

**CAUTION** Always use the three-prong ac power cord supplied with this product. Failure to ensure adequate earth grounding by not using this cord may cause product damage.

---

**CAUTION** This instrument has an autoranging line voltage input; be sure the supply voltage is within the specified range.

---

## ESD Information

### Protection from Electrostatic Discharge

Electrostatic discharge (ESD) can damage or destroy electronic components. All work on electronic assemblies should be performed at a static-safe workstation. **Figure 1-1** shows an example of a static-safe workstation using two types of ESD protection:

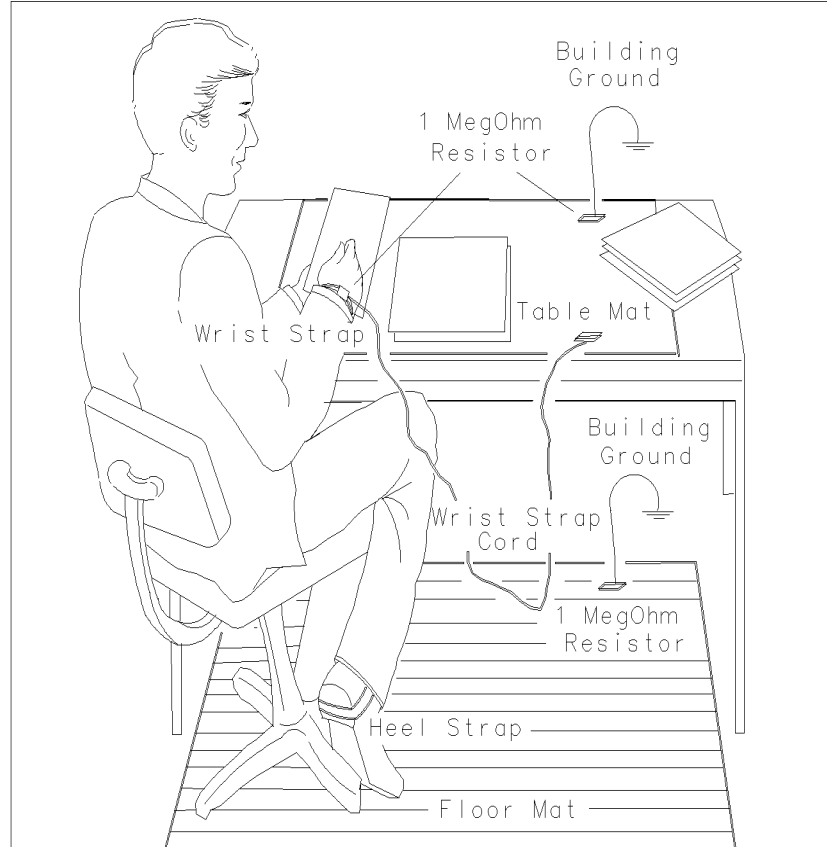
- Conductive table-mat and wrist-strap combination.
- Conductive floor-mat and heel-strap combination.

Both types, when used together, provide a significant level of ESD protection. Of the two, only the table-mat and wrist-strap combination provides adequate ESD protection when used alone. To ensure user safety, the static-safe accessories must provide at least 1 megohm of isolation from ground.

#### **WARNING**

These techniques for a static-safe workstation should not be used when working on circuitry with a voltage potential greater than 500 volts.

Figure 1-1 Example of a Static-Safe Workstation



## Handling of Electronic Components and ESD

The possibility of unseen damage caused by ESD is present whenever components are transported, stored, or used. The risk of ESD damage can be greatly reduced by paying close attention to how all components are handled.

- Perform work on all components at a static-safe workstation.
- Keep static-generating materials at least one meter away from all components.
- Store or transport components in static-shielding containers.

### **CAUTION**

**Always handle printed circuit board assemblies by the edges. This will reduce the possibility of ESD damage to components and prevent contamination of exposed plating.**

---

## Test Equipment Usage and ESD

- Before connecting any coaxial cable to an analyzer connector, momentarily short the center and outer conductors of the cable together.
- Personnel should be grounded with a 1 megohm resistor-isolated wrist-strap before touching the center pin of any connector and before removing any assembly from the analyzer.
- Be sure that all analyzers are properly earth-grounded to prevent build-up of static charge.

## For Additional Information about ESD

For more information about preventing ESD damage, contact the Electrical Over Stress/Electrostatic Discharge (EOS/ESD) Association, Inc. The ESD standards developed by this agency are sanctioned by the American National Standards Institute (ANSI).

## Service Equipment You Will Need

There are certain things that will be required to troubleshoot, adjust, and test the MXA Signal Analyzer. They include the following:

- Calibration Application Software
- Front End Controller Troubleshooting Kit
- USB Keyboard and Mouse
- USB Storage Device
- Test Equipment

### Calibration Application Software

Information regarding the Keysight X-Series Signal Analyzer Calibration Application Software can be found at the following web site:

[www.keysight.com/find/calibrationsoftware](http://www.keysight.com/find/calibrationsoftware)

## Front End Controller Troubleshooting Kit

The Front End Troubleshooting kit contains a PC board, required cables, and installation instructions to verify the switch control logic from the A15 Front End Control board to the lower level front end components is correct. Oftentimes when troubleshooting an RF front end problem, the logic needs to be verified before one of the front end components is changed. This troubleshooting kit will help identify the defective area in a timely manner. In order to effectively isolate A15 Front End Control board problems from front end component problems, it is highly recommended that the N9020-60005 Front End Troubleshooting kit is purchased.

The Front End Troubleshooting kit lower level items can be purchased individually or as a complete kit with instructions. The complete listing of kit components, descriptions, and part numbers can be found below.

Keysight Part	Keysight Part Number	Notes
Front End Troubleshooting kit	N9020-60005	
Front End Troubleshooting board	E4410-60115	Part of N9020-60005 Troubleshooting kit
Cable, Low Band switch	E4410-60160	Part of N9020-60005 Troubleshooting kit
Cable, RF Downconverter	E4410-60156	Part of N9020-60005 Troubleshooting kit
Cable, YTF Preselector	E4410-60158	Part of N9020-60005 Troubleshooting kit
Cable, Input Attenuators	E4410-60157	Part of N9020-60005 Troubleshooting kit
Cable, Troubleshooting	8121-1400	
Connector, MMCX (f) to SMA (f)	n/a	<a href="http://www.hubersuhner.com">www.hubersuhner.com</a> item number: 31_MMCX-SMZ-50-1/111_OE



## USB Keyboard and Mouse

A USB keyboard and mouse will be needed to accomplish many of the different troubleshooting tasks, as well as updating the instrument software. Any standard USB keyboard and mouse should work, but you can use the optional keyboard and mouse sold for the instrument. These can be purchased as:

Description	Option Number	Upgrade Option	Part Number <sup>a</sup>
USB Keyboard	N9020A-KYB	N9020AK-KYB	0960-2933
USB Mouse	N9020A-MSE	N9020AK-MSE	0960-2670

a. Part number is subject to change.

## USB Storage Device

The main reason why a USB storage device will be needed is to backup calibration data when the hard drive in an instrument needs to be replaced. Most any size of storage device can be used, as the size of the file to be backed up is not much larger than a few megabytes. An optional 512 MB device can be ordered along with an instrument as N9020A-EFM, as an upgrade as N9020AK-EFM, or by using the part number 1819-0195.

**NOTE** The memory capacity and part number of the USB storage device supplied with N9020A/AK-EFM is subject to change.

---

## Required Test Equipment List

The following table identifies the equipment recommended for troubleshooting, adjusting, and verifying the performance of the instrument. Only the recommended and alternate equipment is compatible with the performance verification testing. Some tests can use various models of a particular equipment type. The “Recommended Keysight Model” is the preferred equipment. However, the “Alternative Keysight Model” is an acceptable substitute.

**Table 1-1 Required Test Equipment**

Instrument	Critical Specifications	Recommended Model <sup>a</sup>	Alternative Model	Use <sup>b</sup>
<b>Signal Sources</b>				
Microwave Signal Generator #1	Frequency: 10 MHz to 26.5 GHz Frequency Resolution: 1 Hz Harmonic level: < -30 dBc Amplitude range: -40 dBm to +13 Amplitude resolution: 0.02 VSWR: < 20 GHz: 1.6:1 ≤ 31 GHz: 1.8:1	E8257D (Option 567, 1EA/1EU, 1E1) (Option 007, Analog Ramp Sweep, required for Frequency Response Adjustments)	For Adjustments: 83630A/B/L (Option 001, 008), 83640A/B/L (Option 001, 008), 83650A/B/L (Option 001, 008), PSG <sup>c</sup>  For Performance Tests: 83630A/B (Option 001, 008), 83640A/B (Option 001, 008), 83650B (Option 001, 008)  PSG <sup>c</sup>	A, P, T
Microwave Signal Generator #2 (only required for Third Order Intermodulation and Gain Compression)	Frequency: 10 MHz to 26.5 GHz Frequency Resolution: 1 Hz Harmonic level: < -30 dBc Amplitude range: -20 dBm to +13 Amplitude resolution: 0.02 VSWR: < 20 GHz: 1.6:1 ≤ 31 GHz: 1.8:1	E8257D (Option 1EA/1EU)	83630A/B (Option 008), 83640A/B (Option 008), 83650A/B (Option 008) PSG <sup>c</sup>	P
Low Noise Signal Generator (one PSG may be used for multiple sources. See footnote <sup>c</sup> )	Frequency: 50 MHz to 1.0 GHz Harmonics: < -30 dBc ≤ +13 dBm Spectral Purity SSB Phase Noise @ 1 GHz: -112 dBc at 100 Hz offset -121 dBc at 1 kHz offset -131 dBc at 10 kHz offset VSWR: < 1.5:1	E8257D (Options UNR, UNX)	8663A  PSG <sup>c</sup> (Options UNR, UNX)	A, P, T

**Table 1-1 Required Test Equipment**

<b>Instrument</b>	<b>Critical Specifications</b>	<b>Recommended Model<sup>a</sup></b>	<b>Alternative Model</b>	<b>Use<sup>b</sup></b>
Ultra Low Noise Reference Frequency Source (required for testing PXA Phase Noise) (required for MXA's with Option EP2)	Phase Noise (dBc/Hz) for 1 GHz tone and these offsets: 100 Hz –104 dBc/Hz 1 kHz –132 dBc/Hz 10 kHz –144 dBc/Hz 30 kHz –146 dBc/Hz 100 kHz –148 dBc/Hz 1 MHz –157 dBc/Hz 10 MHz –164 dBc/Hz	Wenzel Associates Inc. <sup>d</sup> Ultra Low Noise Reference Frequency Source Model 500-13428 Rev C		P, T
RF Signal Generator (one PSG may be used for multiple sources. See footnote <sup>c</sup> )	Frequency: 300 kHz to 3.6 GHz Frequency Resolution: 1 Hz Harmonic level: < –40 dBc Amplitude range: -20 dBm to +13 Amplitude resolution: 0.02 Harmonic level: < 2 GHz, < -30 dBc ≥ 2 GHz & < 26.5 GHz, < -50 dBc VSWR: < 20 GHz: 1.6:1 ≤ 31 GHz: 1.8:1 For Option UNR or UNX: Harmonics: < –30 dBc ≤ +13 dBm Spectral Purity SSB Phase Noise @ 1 GHz: –112 dBc at 100 Hz offset –121 dBc at 1 kHz offset –131 dBc at 10 kHz offset VSWR: < 1.5:1	E8257D (Options UNR, UNX)	8665B (for Freq Resp Phase Noise > 30 kHz test only)  PSG <sup>c</sup> (Options UNR, UNX)	A, P
Function Generator	Frequency: 10 Hz to 300 kHz Amplitude Resolution: 0.1 mv Harmonic Distortion: –35 dBc	33250A (required for Channel Match (Option BBA) test)	33120A (Option 001)	A, P
<b>Counters</b>				
Universal Counter	Frequency: 10 MHz Gate time: 10 to 100 seconds Must be capable of measuring signal at +7 dBm (0.5 Vrms)	53132A	53131A	A, P, T
<b>Meters</b>				
Digital Multimeter	Frequency: 3 Hz to 300 kHz AC Accuracy: ± 0.31% of reading	3458A		A, P, T

Table 1-1 Required Test Equipment

Instrument	Critical Specifications	Recommended Model <sup>a</sup>	Alternative Model	Use <sup>b</sup>
Power Meter	Dual Channel Instrumentation Accuracy: $\pm 0.5\%$ Power Reference Accuracy: $\pm 0.6\%$ Compatible with 8480 series power sensors dB relative mode	N1914A	E4419A/B N1912A	A, P
RF Power Sensor <b>(2 required)</b>	Frequency Range: 100 kHz to 3.6 GHz Amplitude Range: $-30$ to $+20$ dBm Zero Set: $\pm 50$ nW Zero Drift: $< \pm 10$ nW Measurement Noise: $< 110$ nW VSWR 100 kHz to 1 MHz: $\leq 1.20:1$ 1 MHz to 2 GHz: $\leq 1.10:1$ 2 GHz to 3 GHz: $\leq 1.30:1$ Cal Factor Uncertainty (std): $< 1.6\%$ Option H84 Cal Factor: Characterized by standards lab to: $\pm 0.6\%$ <sup>e</sup> Input Connector: Type-N (m)	8482A (Option H84)	N8482A <sup>f</sup> N8482A CFT <sup>f</sup> 8482A <sup>f</sup> (Non-H84 sensors will increase measurement uncertainty)	A, P
Microwave Power Sensor <b>(2 required)</b>	Frequency Range: 50 MHz to 26.5 GHz Amplitude Range: $-30$ to $+20$ dB Zero Set: $\pm 50$ nW Zero Drift: $< \pm 10$ nW Measurement Noise: $< 110$ nW Cal Factor Uncertainty: $< 3.0\%$ VSWR: 50 MHz to 100 MHz: 1.15:1 100 MHz to 2 GHz: 1.10:1 2 GHz to 12.4 GHz: 1.15:1 12.4 GHz to 18 GHz: 1.20:1 18 GHz to 26.5 GHz: 1.25:1 Input Connector: 3.5 mm (m)	N8485A <sup>f</sup>	N8485A CFT <sup>f</sup> 8485A <sup>f</sup>	A, P
Low Power Microwave Power Sensor <b>(2 required)</b> <b>(for Option P08, P13, or P26 only)</b>	Frequency Range: 50 MHz to 26.5 GHz Amplitude Range: $-70$ to $+20$ dBm Zero Set: $\pm 50$ pW Zero Drift: $< \pm 4$ pW Measurement Noise: $< 4$ pW Cal Factor Uncertainty: $< 3.0\%$ VSWR: 50 MHz to 100 MHz: 1.15:1 100 MHz to 2 GHz: 1.10:1 2 GHz to 12.4 GHz: 1.15:1 12.4 GHz to 18 GHz: 1.20:1 18 GHz to 26.5 GHz: 1.25:1 Input Connector: 3.5 mm (m)	8485D <sup>f</sup>		A, P
Power Sensor Cable <b>(2 required)</b>		11730A		A, P, T

Table 1-1 Required Test Equipment

Instrument	Critical Specifications	Recommended Model <sup>a</sup>	Alternative Model	Use <sup>b</sup>
<b>Standards</b>				
Frequency Standard	Frequency: 10 MHz Accuracy: $< \pm 1 \text{ e}10^{-10}$	Symmetricom 5071A	Keysight 5061B, 5071A	A, P
50 MHz, -25 dBm Calibrator	Frequency Drift: $< 2.5 \text{ kHz}$ Typical VSWR: 1.06:1 Output Power Variation: $\pm 0.004 \text{ dB}$ Total Harmonic Content: -45 dBc	Z5602A Opt H51		A
<b>Attenuators</b>				
10 dB Step Attenuator	Range: 0 to 80 dB Accuracy: Characterized by standards lab <sup>g</sup> Calibrated at 50 MHz VSWR: at 50 MHz: $\leq 1.05:1$	8496G (Option 001, H50)	8496H (Option 001, H50)	P
1 dB Step Attenuator	Range: 0 to 9 dB Accuracy: Characterized by standards lab <sup>g</sup> VSWR: at 50 MHz: $\leq 1.05:1$	8494G (Option 001, H50)	8494H (Option 001, H50)	P
Attenuator Interconnect Kit	Type N connector kit to connect 8496G to 8494G	11716A		P
Attenuator Driver	Compatible with the 8496G and 8494G step attenuators	11713B	11713A	P
3 dB Fixed Attenuator	Frequency: 50 MHz Loss: 3 dB (nominal) VSWR: at 50 MHz: $\leq 1.2:1$ Connector: Type-N (m, f)	8491A (Option 003)	8491B (Option 003)	P
6 dB Fixed Attenuator	Frequency: 50 MHz Loss: 6 dB (nominal) VSWR: at 50 MHz: $\leq 1.05:1$ Connector: Type-N (m, f)	8491A (Option 006, H33 <sup>h</sup> )	8491B (Option 006, H33 <sup>h</sup> )	P
6 dB Fixed Attenuator <b>(2 required)</b>	Frequency: 50 MHz to 3.6 GHz Loss: 6 dB (nominal) VSWR: at 50 MHz: $\leq 1.10:1$ Connector: 3.5 mm (m, f)	8493C (Option 006)		A
10 dB Fixed Attenuator	Frequency: 50 MHz Loss: 10 dB (nominal) VSWR: at 50 MHz: $\leq 1.05:1$ Connector: Type-N (m, f)	8491A (Option 010, H33 <sup>h</sup> )	8491B (Option 010, H33 <sup>h</sup> )	P

**Table 1-1 Required Test Equipment**

<b>Instrument</b>	<b>Critical Specifications</b>	<b>Recommended Model<sup>a</sup></b>	<b>Alternative Model</b>	<b>Use<sup>b</sup></b>
10 dB Fixed Attenuator	Frequency: 50 MHz to 19.5 GHz Loss: 10 dB (nominal) VSWR: 321.4 MHz to 8 GHz: ≤ 1.1:1 8 GHz to 12.4 GHz: ≤ 1.15:1 12.4 GHz to 19.5 GHz: ≤ 1.25:1 Connector: 3.5 mm (m, f)	8493C (Option 010)		A, P
20 dB Fixed Attenuator	Frequency: 10 MHz Loss: 20 dB (nominal) VSWR: 10 MHz: ≤ 1.20:1 Connector: Type-N (m, f)	8491A (Option 020)	8491B (Option 020)	A, P
30 dB Fixed Attenuator	Frequency: 50 MHz Loss: 30 dB ± 0.05 dB VSWR: 1.05 @ 50 MHz (For use with Low Power Sensors)	11708A		A, P
<b>Terminations</b>				
Type-N (m) (for Option 503, 508, 513)	Frequency: 10 kHz to 18 GHz VSWR: ≤ 1.05:1	909A (Option 012)		P, T
3.5 mm (f) (for Option 526)	50 Ω Frequency: 10 kHz to 50 GHz	909D (Option 526)		P, T
BNC (m) (required for Option BBA)	Frequency: 50 Hz to 300 kHz	1250-0207		P
<b>Miscellaneous Devices</b>				
RF Power Splitter	Frequency: 9 kHz to 3.6 GHz VSWR: ≤ 1.10:1 Tracking Error: < ± 0.15 δB Connector: Type-N (f)	11667A		A, P
Microwave Power Splitter	Frequency: 50 MHz to 26.5 GHz VSWR: 10 MHz to 3 GHz: < 1.22:1 3 GHz to 26.5 GHz: < 1.22:1 Tracking Error: < ± 0.40 δB Connector: 3.5 mm (f)	11667B		A, P

**Table 1-1 Required Test Equipment**

<b>Instrument</b>	<b>Critical Specifications</b>	<b>Recommended Model<sup>a</sup></b>	<b>Alternative Model</b>	<b>Use<sup>b</sup></b>
Directional Bridge	Frequency Range: 50 MHz to 3 GHz Directivity: 50 MHz to 2 GHz: 40 dB 2 GHz to 3 GHz: 30 dB VSWR: ≤ 2 GHz: ≤ 1.15:1 ≤ 3 GHz: ≤ 1.22:1 Insertion Loss: ≤ 1.5, +0.1 dB/GHz (nominal) Coupling (nominal): 16 dB Connector: Type N (f)	86205A		P
Directional Coupler	Frequency 2 GHz to 20 GHz Directivity > 16 dB Transmission arm loss: < 1.5 dB (nominal) Coupled Arm Loss: ~10 dB (nominal) VSWR: ≤ 1.35:1 Connector: SMA (f)	87300B		P
Microwave Power Divider	Frequency: DC to 500 MHz VSWR: < 1.10:1 Tracking Error: < ± 0.25 dB Connector: 3.5 mm (f)	11636B		A, P
Hybrid Power Divider	Frequency: 500 MHz to 3.6 GHz Isolation: 19 dB Insertion Loss: 4.5 dB (nominal) VSWR: < 1.45:1	87302C		A
<b>Cables</b>				
3.5 mm (m) to 3.5 mm (m) <b>(2 required)</b>	Frequency: DC to 26.5 GHz Length: ≤ 92 cm (36 in.) Insertion Loss: ~2 dB VSWR: DC to 18 GHz: ≤ 1.25:1 18 GHz to 26.5 GHz: ≤ 1.35:1	11500E	8120-4921	A, P
Type-N <b>(2 required)</b>	Frequency: 10 MHz to 8 GHz Precision Type-N (m), both ends 62 cm (24 in.) VSWR: ≤ 18 GHz: 1.4:1 Insertion Loss: 1.5 dB	11500C		A, P, T
BNC <b>(3 required)</b>	Frequency: DC to 10 MHz 50 Ω Coax BNC (m), both ends 120 cm (48 in.)	10503A		A, P, T

Table 1-1 Required Test Equipment

Instrument	Critical Specifications	Recommended Model <sup>a</sup>	Alternative Model	Use <sup>b</sup>
<b>Filters</b>				
50 MHz Low Pass	Cutoff Frequency: 50 MHz Rejection at 65 MHz: > 40 dB Rejection at 75 MHz: > 60 dB Insertion Loss: ~1 dB VSWR: ≤ 1.5:1 BNC (m) to BNC (f)	Telonic Berkeley TLA 50-5AB2	0955-0306	P,T
300 MHz Low Pass <b>(2 Required)</b>	Cutoff Frequency: 300 MHz Rejection at > 435 MHz: > 45 dB VSWR: ≤ 1.5:1 BNC (m, f)	Telonic Berkeley TLP 300-4AB4	0955-0455	P
1.8 GHz Low Pass <b>(2 Required)</b>	Cutoff frequency: 1.8 GHz Rejection at 2.1 GHz to 6 GHz: > 45 dB Insertion Loss @ 1.8 GHz: < 1 dB VSWR: ≤ 1.50:1 DC to 1.8 GHz Connector: SMA (f) to SMA (f)	RLC L-1636	0955-0491	P
4.4 GHz Low Pass <b>(2 Required)</b>	Cutoff frequency: 4.4 GHz Rejection at > 5.5 GHz: > 42 dB Insertion Loss @ 1.8 GHz: < 1 dB VSWR: ≤ 1.50:1 DC to 1.8 GHz Connector: SMA (f) to SMA (f)	K + L ML253-4499/XU -N/NP	9135-0005 360D	P
5.0 GHz Low Pass	3 dB frequency: 5.25 GHz 60 dB Rejection: > 6.7 GHz VSWR: 1.35:1	RLC F-30-5000-RF		P
8.0 GHz Low Pass	3 dB frequency: 8.4 GHz 60 dB Rejection: > 10.8 GHz VSWR: 1.35:1	RLC F-30-8000-RF		P
12.4 GHz Low Pass	3 dB frequency: 13.0 GHz 60 dB Rejection: > 16.74 GHz VSWR: 1.35:1	RLC F-30-12.4-RF		P
<b>Adapters</b>				
Type-N (f) to Type-N (f)	Frequency: DC to 18 GHz VSWR: ≤ 1.13:1	1250-1472		P
Type-N (m) to Type-N (m)	Frequency: DC to 18 GHz VSWR: ≤ 1.13:1	1250-1475		P
Type-N (f) to BNC (m)	Frequency: DC to 1.3 GHz VSWR: ≤ 1.13:1	1250-1477		P, T
Type-N (m) to BNC (m)	Frequency: DC to 1.3 GHz VSWR: ≤ 1.13:1	1250-1473		P, T



**Table 1-1 Required Test Equipment**

<b>Instrument</b>	<b>Critical Specifications</b>	<b>Recommended Model<sup>a</sup></b>	<b>Alternative Model</b>	<b>Use<sup>b</sup></b>
Type-N (m) to BNC (f)	Frequency: DC to 1.3 GHz VSWR: ≤ 1.13:1	1250-1476		P
Type-N (m) to 3.5 mm (m)	Frequency: DC to 18 GHz VSWR: ≤ 1.08:1	1250-1743		P
Type-N (m) to 3.5 mm (f) <b>(2 Required)</b>	Frequency: DC to 18 GHz VSWR: ≤ 1.08:1	1250-1744		P
3.5 mm (f) to Type-N (f) (for 3.5 mm source)	Frequency: DC to 18 GHz VSWR: ≤ 1.08:1	1250-1745		A, P
Type-N (f) to 3.5 mm (m)	Frequency: DC to 18 GHz VSWR: ≤ 1.14:1	1250-1750		A, P
3.5 mm (f) to 3.5 mm (f) (for 3.5 mm source)	Frequency: DC to 26.5 GHz VSWR: ≤ 1.05:1	83059B	1250-1749	P
3.5 mm (m) to 3.5 mm (m) <b>(2 Required)</b>	Frequency: DC to 26.5 GHz VSWR: ≤ 1.12:1	83059A	1250-1748	P
3.5 mm (f) to 2.4 mm (f) (for 2.4 mm source)	Frequency: DC to 26.5 GHz VSWR: ≤ 1.05:1	11901B		P
Type-N (f) to 2.4 mm (f) (for 2.4 mm source)	Frequency: DC to 18 GHz VSWR: ≤ 1.08:1	11903B		P
BNC (m) to SMA(f)	Frequency: DC to 1.3 GHz VSWR: ≤ 1.13:1	1250-1700		P
BNC Tee (BNC f,m,f)		1250-0781		A, P
SMB (f) to BNC (f)	Frequency: DC to 1.3 GHz	1250-1236		A, P
BNC (f) to SMA (m)	Frequency: DC to 1.3 GHz	1250-1200		A, P
BNC (f) to Dual Banana		1251-2277		A, P
3.5 mm (f) to Type-N (m)	Shipped with the 8485A for adapting to the Power Reference. Only to be used for power sensor cal.	08485-60005		A, P
Type-N Tee		1250-0559		P
<b>Optional Equipment</b>				
10 MHz Distribution Amplifier (only needed when using the 10 MHz Distribution Amplifier Setup)		Symmetricom 5087B	Keysight 5087A	A, P

**Table 1-1 Required Test Equipment**

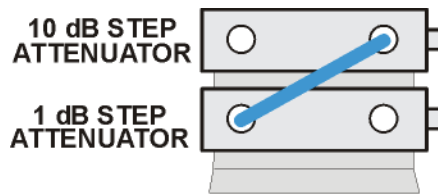
Instrument	Critical Specifications	Recommended Model <sup>a</sup>	Alternative Model	Use <sup>b</sup>
1 GHz Notch Filter (for alternate Phase Noise setup)	Center Frequency: 1.0001 GHz	Trilithic CFN-2-1000.1		P

- a. Keysight model numbers unless otherwise noted.
- b. A = Adjustments, P = Performance Testing, T = Troubleshooting
- c. Supported PSG models:

E8244A  
E8247C  
E8254A  
E8257C  
E8257D  
E8267C  
E8267D

Note: One PSG with Option 567, 1EA, 1E1, 007, and UNX or UNR can be used as the Microwave Signal Generator #1, Low Noise Signal Generator (for MXA's without Option EP2), and the RF Signal Generator.

- d. Wenzel Associates Inc., 2215 Kramer Ln., Austin, TX 78758 (512) 835-2038 Fax (512) 719-4086
- e. The 8482A power sensor uses cal factors to compensate the power sensor for frequency response errors. Cal factors are stated in percentages. The 8482A factory cal factor uncertainty ranges from 2.2% to 3.1%. The cal factor uncertainty can be reduced to < 1.0% by using metrology grade calibration techniques. The power sensor cal factor uncertainty becomes one component of the Verification Test uncertainty analysis. Lower cal factor uncertainties will translate to wider test margins.
- f. When ordering a new STD or CFT Power Sensor from Keysight to be used with the N7800A series applications, order with Option 1A7. The 1A7 option provides an ISO17025 calibration and includes calibration data. When re-calibrating your STD or CFT Power Sensor for use with the N7800A series applications, we recommend the Keysight ISO17025 calibration.
- g. The step attenuators should be permanently joined via the 11716A Interconnect Kit as shown in the following diagram.



step\_atten\_setup

For more information on step attenuator characterization, see the **“Step Attenuator Loss Characterization”** section below.

Overview  
Service Equipment You Will Need

- h. 8491A Option H33 is a fixed attenuator which has been characterized to have a VSWR  $\leq 1.05:1$  at 50 MHz. A VSWR of 1.05:1 is recommended to test Input Attenuator Switching Uncertainty, Display Scale Fidelity, and Absolute Amplitude Accuracy performance tests. Any 8491A/B attenuator can be mapped into this device if the VSWR at 50 MHz has been characterized to be  $\leq 1.05:1$ . When mapping the attenuator, to indicate that it meets the required specification, the Option H33 checkbox will need to be checked in the configure test station Administration screen.

### Step Attenuator Loss Characterization

The step attenuator combination should have each attenuator setting characterized by a metrology lab at 50 MHz. The following tables show which sections of the 10 dB and 1 dB step attenuators are utilized for each attenuator setting. The tables also list the Allowable Uncertainty for each attenuator setting. The interconnect cable should NEVER be disconnected once the loss characterization is performed.

Table 1-2 1 dB Step Attenuator

Nominal Attenuation (dB)	Attenuator Section				Allowable Uncertainty (dB)
	#1 (1 dB)	#2 (2 dB)	#3 (4 dB)	#4 (4 dB)	
0	Off	Off	Off	Off	0 (Reference)
1	On	Off	Off	Off	< 0.005
2	Off	On	Off	Off	< 0.005
3	On	On	Off	Off	< 0.005
4	Off	Off	On <sup>a</sup>	Off	< 0.005
5	On	Off	On	Off	< 0.005
6	Off	On	On	Off	< 0.005
7	On	On	On	Off	< 0.005
8	Off	Off	On	On	< 0.005
9	On	Off	On	On	< 0.005

a. TME requires that Section 3 be characterized.

Table 1-3 10 dB Step Attenuator

Nominal Attenuation (dB)	Attenuator Section				Allowable Uncertainty (dB)
	#1 (10 dB)	#2 (20 dB)	#3 (40 dB)	#4 (40 dB)	
0	Off	Off	Off	Off	0 (Reference)
10	On	Off	Off	Off	< 0.010
20	Off	On	Off	Off	< 0.015
30	On	On	Off	Off	< 0.020
40	Off	Off	On <sup>a</sup>	Off	< 0.025
50	On	Off	On	Off	< 0.030

Table 1-3 10 dB Step Attenuator

Nominal Attenuation (dB)	Attenuator Section				Allowable Uncertainty (dB)
	#1 (10 dB)	#2 (20 dB)	#3 (40 dB)	#4 (40 dB)	
60	Off	On	On	Off	< 0.035
70	On	On	On	Off	< 0.040

a. TME requires that Section 3 be characterized.

## After an Instrument Repair

If any instrument assemblies have been repaired or replaced, perform the related adjustments and performance verification tests. These tests are done using the N7814A Keysight X-Series Signal Analyzer Calibration Application Software. Refer to **Chapter 15, “Post-Repair Procedures”** for a list of post-repair adjustments and performance tests based on which hardware has been changed.

Information regarding the N7814A Keysight X-Series Signal Analyzer Calibration Application Software can be found at

<http://www.keysight.com/find/calibrationsoftware>

## Contacting Keysight Technologies

If you have a problem with your instrument, see **Chapter 2, “Boot Up and Initialization Troubleshooting”**. This section contains a checklist that will help identify some of the most common problems.

There is also support on the world-wide web. The address is:

[http://www.keysight.com/find/mxa\\_support](http://www.keysight.com/find/mxa_support)

FAQs, instrument software updates, documentation, and other support information can be accessed from this site.

To obtain servicing information or to order replacement parts, contact the nearest Keysight office listed in **Table 1-4**. In any correspondence or telephone conversations, refer to the instrument by its model number (N9020A) and full serial number (ex. MY49250887). With this information, the Keysight representative can quickly determine whether your unit is still within its warranty period.

By internet, phone, or fax, get assistance with all your test and measurement needs.

Table 1-4

## Contacting Keysight

Online assistance: [www.keysight.com/find/contactus](http://www.keysight.com/find/contactus)

### Americas

Country	Phone Number
Canada	(877) 894 4414
Brazil	55 11 3351 7010
Mexico	001 800 254 2440
United States	1 800 829-4444

### Asia Pacific

Country	Phone Number
Australia	1 800 629 485
China	800 810 0189
Hong Kong	800 938 693
India	1 800 112 929
Japan	0120 (421) 345
Korea	080 769 0800
Malaysia	1 800 888 848
Singapore	1 800 375 8100
Taiwan	0800 047 866
Other AP Countries	(65) 6375 8100

### Europe and Middle

Country	Phone Number
Austria	0800 001122
Belgium	0800 58580
Finland	0800 523252
France	0805 980333
Germany	0800 6270999
Ireland	1800 832700
Israel	1 809 343051
Italy	800 599100



**Europe and Middle**

<b>Country</b>	<b>Phone Number</b>
Luxembourg	+32 800 58580
Netherlands	0800 0233200
Russia	8800 5009286
Spain	0800 000154
Sweden	0200 882255
Switzerland	0800 805353 Opt. 1 (DE) Opt. 2 (FR) Opt. 3 (IT)
United Kingdom	0800 0260637

**For other unlisted countries:**

[www.keysight.com/find/contactus](http://www.keysight.com/find/contactus)

## Instrument Serial Numbers

Keysight makes frequent improvements to its products enhancing performance, usability, or reliability. Keysight service personnel have access to complete records of design changes to each type of instrument, based on the instrument's serial number and option designation.

Whenever you contact Keysight about your instrument, have the complete serial number available. This will ensure that you obtain accurate service information.

A serial number label is attached to the rear of the instrument. This label has two instrument identification entries: the first provides the identification number for each option built into the instrument and the second provides the instrument's serial number.

The serial number has two parts: the prefix (two letters and the first four numbers), and the suffix (the last four numbers). Refer to the following figure.

Figure 1-2

### Example Serial Number



The first two letters of the prefix identify the country in which the unit was manufactured. The remaining four numbers of the prefix identify the date of the last major design change incorporated in your instrument. The four digit suffix is a sequential number and, coupled with the prefix, provides a unique identification for each unit produced. Whenever you list the serial number or refer to it in obtaining information about your instrument, be sure to use the complete number, including the full prefix and the suffix.

The serial number is located on the rear panel serial sticker or when the analyzer is power up, press **System, Show, System**. The system information can be very useful for updates and post-sale upgrades.

## How to Return Your Instrument for Service

### Service Order Number

If an instrument is being returned to Keysight for servicing, the phone numbers are mentioned in **Table 1-4, “Contacting Keysight,” on page 40**. In order for Keysight to expedite the repair please be as specific as possible about the nature of the failure.

#### **Helpful failure descriptions:**

- Signal level measures 10 dB too low at 1 GHz
- L.O. Unlock error message appears on screen in spans < 10 MHz
- Analyzer will not complete boot up sequence to signal analyzer mode

#### **Failure descriptions that will most likely increase repair time:**

- Analyzer broken
- Analyzer will not make accurate measurements
- Signal drifts

If you have recorded any error messages that appeared on the analyzer display, or have completed a Functional Test or Performance Verification Test, or have any other specific data on the performance of the instrument, please send a copy of this information with the instrument.

### Original Packaging

Before shipping, pack the unit in the original factory packaging materials if they are available. If the original materials were not retained, see **“Other Packaging” on page 44**.

## Other Packaging

### CAUTION

Instrument damage can result from using packaging materials other than those specified. Never use styrene pellets in any shape as packaging materials. They do not adequately cushion the equipment or prevent it from shifting in the carton. They cause equipment damage by generating static electricity and by lodging in the instrument louvers, blocking airflow.

---

You can repackage the instrument with commercially available materials, as follows:

1. Protect the control panel with cardboard.
2. Wrap the instrument in antistatic plastic to reduce the possibility of damage caused by electrostatic discharge.
3. Use a strong shipping container. A double-walled, corrugated cardboard carton with 159 kg (350 lb) bursting strength is adequate. The carton must be both large enough and strong enough to accommodate the instrument. Allow at least 3 to 4 inches on all sides of the instrument for packing material.
4. Surround the equipment with three to four inches of packing material and prevent the equipment from moving in the carton. If packing foam is not available, the best alternative is S.D.-240 Air Cap™ from Sealed Air Corporation, Hayward, California, 94545.  
  
Air Cap looks like a plastic sheet filled with 1-1/4 inch air bubbles. Use the pink-colored Air Cap to reduce static electricity. Wrapping the equipment several times in this material should both protect the equipment and prevent it from moving in the carton.
5. Seal the shipping container securely with strong nylon adhesive tape.
6. Mark the shipping container “FRAGILE, HANDLE WITH CARE” to assure careful handling.
7. Retain copies of all shipping papers.

## 2 Boot Up and Initialization Troubleshooting

### What You Will Find in This Chapter

This chapter provides information that is useful when starting to troubleshoot a spectrum analyzer. It includes procedures for troubleshooting common failures and provides information on isolating problems in the analyzer.

The following sections are found in this chapter:

[Check the Basics on page 46](#)

[Instrument Boot Up Process on page 47](#)

[Typical instrument boot-up process flow on page 48](#)

[Potential Problems During Boot Process on page 51](#)

[Yellow Standby LED Does Not Illuminate on page 51](#)

[Green Power On LED Does Not Illuminate on page 53](#)

[Fan\(s\) Are Not Operating on page 55](#)

[No Agilent Splash Screen Displayed on page 57](#)

[Instrument Hangs at the Agilent Splash Screen on page 58](#)

[PCI Enumeration Error on page 58](#)

[Instrument Cannot Completely Load or Run the Operating System on page 59](#)

[Troubleshooting a Blank Display on page 59](#)

[Initializations Did Not Complete on page 63](#)

[Fails an Initial Alignment on page 64](#)

[Signal Level Verification on page 70](#)

[Signal Level Problem with Input Frequencies < 3.6 GHz on page 70](#)

[Signal Level Problem with Input Frequencies > 3.6 GHz on page 71](#)

## Check the Basics

Before calling Keysight Technologies or returning the instrument for service, please make the following checks:

1. Is there power at the power outlet? At the power receptacle on the instrument?
2. Is the instrument turned on? Check to see if the front panel LED is green, which indicates the power supply is on.
3. If other equipment, cables, and connectors are being used with the instrument, make sure they are connected properly.
4. Review the procedure for the measurement being performed when the problem appeared. Are all the settings correct?
5. If the instrument is not functioning as expected, return the unit to a known state by pressing the **Mode Preset** key.
6. Is the measurement being performed, and the results that are expected, within the specifications and capabilities of the instrument? Refer to the specifications book for specifications.
7. In order to meet specifications, the instrument must be aligned. Press **System, Alignments, Align Now, All**. The diagnostic tests should all pass. If the instrument displays a failure during these tests, refer to [“Fails an Initial Alignment” on page 64](#).
8. Check to see if the instrument has the latest firmware before starting the troubleshooting procedure. Press **System, Show System**. The firmware revision is listed under **Firmware Revision**. For more information, refer to [“Instrument Software” on page 635](#).
9. Is the instrument displaying an error message? If so, refer to [Chapter 3, “Instrument Messages”, on page 73](#) for more information.
10. If the necessary test equipment is available, perform the functional checks in [Chapter 16, “Functional Tests”, on page 599](#).

## Instrument Boot Up Process

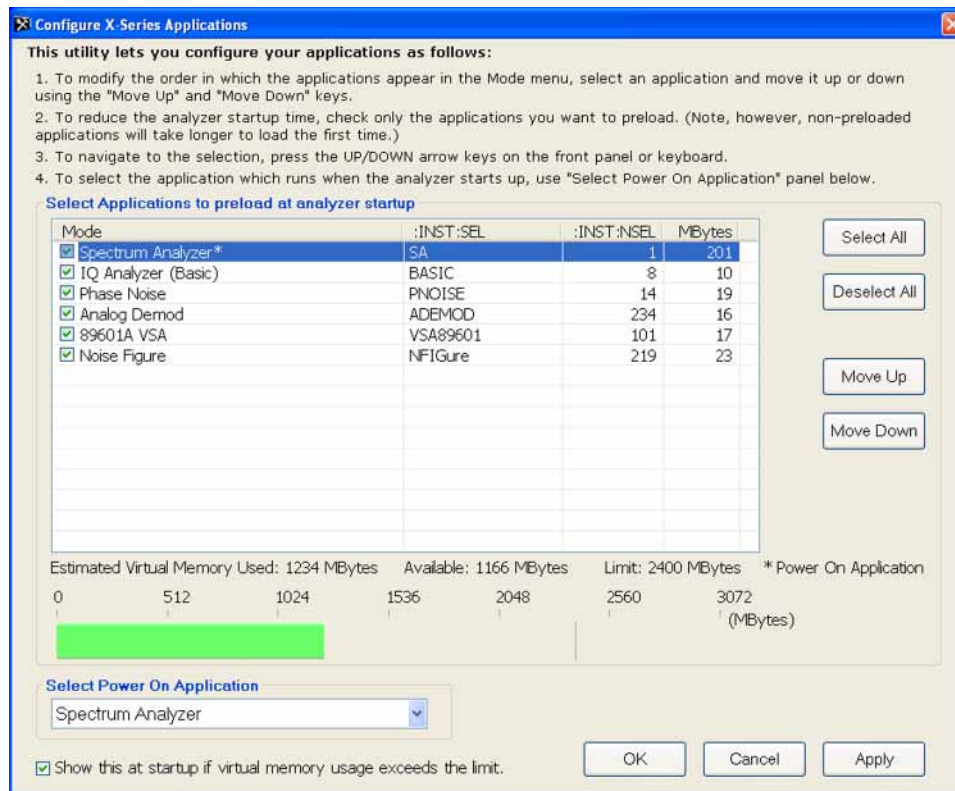
This section describes the signal analyzer boot up process from initial AC power to a normal analyzer sweep. The boot process time from start to finish will take 3 to 4 minutes. This boot time will vary slightly depending on the analyzer hardware configuration, installed options and the number of measurement applications.

By default, the measurement applications will preload before the spectrum analyzer application is fully booted. The analyzer boot time can be shortened if needed by turning off the preload process for applications that are not going to be used. If this is done, the preload process will be bypassed during the application boot up. If a certain measurement mode is selected that did not preload during the original boot, that measurement application will preload at that time. When this occurs the mode switching time will take longer. Once the application is loaded all subsequent mode switches will be much faster.

If the user does not want the measurement applications to preload during the application boot process, select the Configure Applications icon on the desktop. This will bring up a window as shown in **Figure 2-1** that shows the various applications and what is selected to preload. By default all applications are checked and therefore, will preload when the MXA application is launched. Uncheck any applications to bypass the preloading process, select Apply, and then OK to close the Configure Applications window when finished.

Figure 2-1

Configure Application



## Typical instrument boot-up process flow

1. Plug in the AC power cord from a known good AC power source into the rear panel of the analyzer.
2. The yellow standby LED illuminates on the analyzer front panel to the left-hand side of the On/Off button. If the yellow Standby LED is not illuminating refer to the “Yellow Standby LED Does Not Illuminate” section in this chapter.
3. To turn the analyzer on, press the On/Off button. The yellow Standby LED should turn off and the green Power On LED should illuminate. A green Power On LED indicates that the power supply has received an “On” command from the A4 CPU assembly. If the green Power On LED is not illuminating refer to the “Green Power On LED Does Not Illuminate” section in this chapter.

### NOTE

If the analyzer AC power source was removed by the operator by pulling the power cord or by turning off the analyzer via a power main switch on a test rack, the analyzer will automatically power on without having to press the On/Off button on the front panel.

---



4. The instrument fans should start running. The fans are mounted on the left-hand side of the analyzer and draw air into the instrument to cool the internal circuitry. If a fan is not running refer to the **“Fan(s) Are Not Operating”** section in this chapter.
5. The Agilent Technologies splash screen is displayed in white font on a dark background for ~5-10 seconds after the analyzer is turned on. If the Agilent Technologies logo is not displayed refer to the **“No Agilent Splash Screen Displayed”** section in this chapter. If the instrument hangs at the Agilent Technologies splash screen refer to the **“Instrument Hangs at the Agilent Splash Screen”** section in this chapter.
6. Verify text is displayed on screen where the user has the option of booting Windows XP or running the Agilent Recovery System. The default selection is to boot Windows XP. If a recovery is required, press the Down Arrow key on the front panel of the analyzer within 5 seconds to highlight “Agilent Recovery System” and press the Enter key on the analyzer, otherwise Windows XP will begin to boot. If the Windows XP boot screen is not displayed within a few seconds refer to the **“Instrument Cannot Completely Load or Run the Operating System”** section in this chapter.
7. If the recovery system is not selected the Windows XP Professional operating system will begin to boot up. This will take ~20-30 seconds.

**NOTE**

If a recovery was selected follow the on-screen instructions and perform a system recovery. Additional information about performing a system recovery can be found in **Chapter 8, “CPU/Disk Drive Troubleshooting”**, on page 305 in this manual.

---

8. The Agilent Technologies logo is displayed in white font on a blue background while Windows finishes loading user preferences. This can take up to 4 minutes. If this does not occur refer to the **“Instrument Cannot Completely Load or Run the Operating System”** section in this chapter.
9. By default, the initialization process of the MXA Spectrum Analyzer application begins loading. The N9020A MXA Signal Analyzer screen appears. The screen remains for slightly over 1 minute. If any of the initializing processes do not complete, refer to the **“Initializations Did Not Complete”** section in this chapter.
10. While the application software is loading the instrument will perform a number of internal alignments before the analyzer begins to sweep. A screen with a black background appears and the alignment progress is shown in a yellow box. The number of alignments is dependent on which hardware options are present. If an alignment fails, refer to the **“Fails an Initial Alignment”** section in this chapter.

11. If any of the initial alignments fail, check the alignment history for troubleshooting hints.

The instrument alignment history can be found at:

**E:\AlignDataStorage\AlignmentHistory.txt**

Look for any failed status for the various internal hardware items listed in this file.

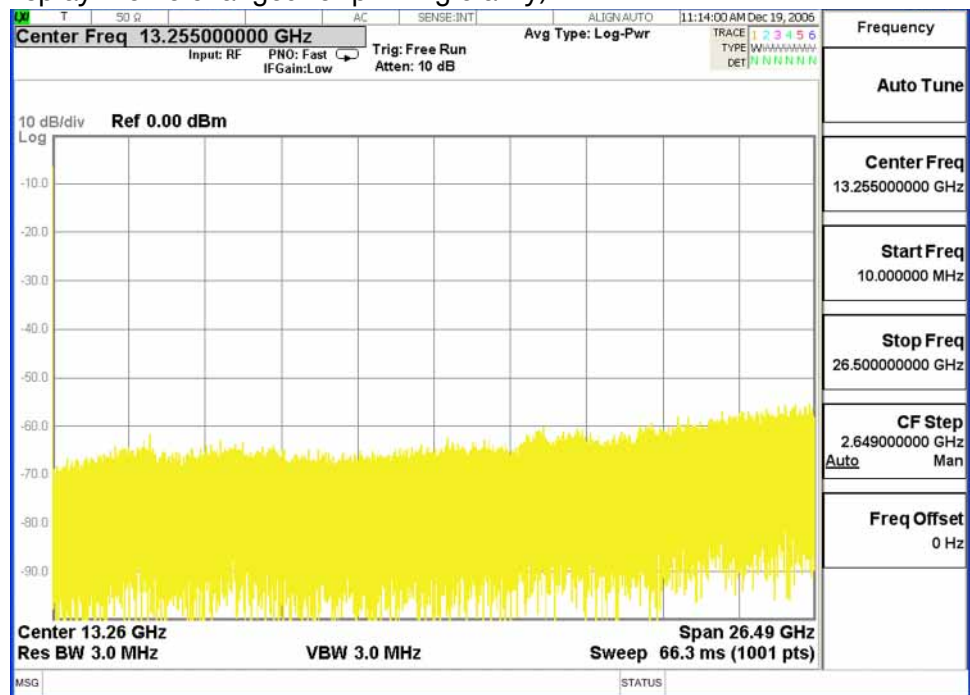
Once the MXA application is fully initialized and aligned, the sweep should resemble **Figure 2-2** when delivered from the factory. This completes the boot process from initial AC power to the spectrum analyzer application.

**IMPORTANT**

If the power up state has been changed from the factory power on state by the user, the analyzer will boot to that state.

Figure 2-2

Typical Instrument Sweep at Power-up  
(Display theme changed for printing clarity)



## Potential Problems During Boot Process

This section describes potential problems that may occur if there is an internal hardware issue that prohibits the MXA from completing a full boot up to the spectrum analyzer application.

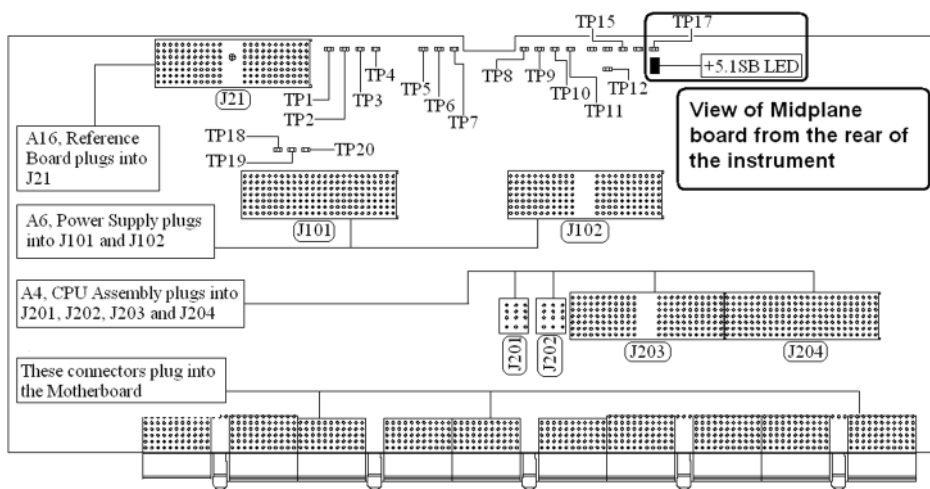
### Yellow Standby LED Does Not Illuminate

Control of the yellow front panel Standby LED comes from the A4 CPU board assembly. This signal is routed through the A7 Midplane board and is then buffered on the A8 Motherboard before being sent to the A1A2 Front Panel Interface board through W1. Of course, the power for this all originates with the A6 Power Supply Assembly. When the Standby LED does not come on it could be due to any one of these assemblies. This procedure will help to determine which one is the cause.

If the instrument turns on and operates properly but the yellow Standby LED does not work then all that will need to be done is to trace where the control signal for the LED is being lost using the routing information in the preceding paragraph.

1. The Standby LED will only turn on when the instrument is connected to an AC source that has a voltage level and frequency of that specified for the instrument. Before proceeding verify that these requirements are being met. Refer to the instrument rear panel for these requirements.
2. Remove the AC power cord and then remove the instrument cover. Refer to the [Chapter 14, "Assembly Replacement Procedures"](#), on page 435 in this manual.
3. Refer to [Figure 2-3](#), verify the +5.1V standby LED on the A7 Midplane board is on.

**Figure 2-3** A7 Midplane Board +5.1V LED



**NOTE** All DC power supplies come from the A6 Power Supply assembly. However, the most convenient measurement location for all the DC supplies is the A7 Midplane. All power supply LED's are accessible once the instrument cover has been removed.

---

Is the +5.1SB LED on the A7 Midplane board on?

**If yes:**

After verifying that the connections from the front panel Standby LED back to the A4 CPU board are not at fault, replace the A4 CPU board.

**If no:**

Replace the A6 Power Supply assembly.

**NOTE** Before replacing the power supply, verify the midplane and motherboard interconnects are mechanically secure.

---

## Green Power On LED Does Not Illuminate

Control of the green front panel Power On LED comes from the A4 CPU board assembly. This signal is routed through the A7 Midplane board and is then buffered on the A8 Motherboard before being sent to the A1A2 Front Panel Interface board through W1. Of course, the power for this all originates with the A6 Power Supply Assembly. When the Power On LED does not come on it could be due to any one of these assemblies. This procedure will help to determine which one is the cause.

This procedure assumes that the yellow Standby LED does turn on when the AC power is connected to the rear panel of the instrument. If it doesn't, refer to the **“Yellow Standby LED Does Not Illuminate”** section before proceeding.

If the instrument turns on and operates properly but the green Power On LED does not work then all that will need to be done is to trace where the control signal for the LED is being lost using the routing information in the preceding paragraph.

1. The Power On LED will only turn on when the instrument is connected to an AC source that has a voltage level and frequency of that specified for the instrument and the front panel On/Off button has been pressed. Before proceeding verify that these requirements are being met. Refer to the instrument rear panel for these requirements.
2. Remove the AC power cord and then remove the instrument cover. Refer to **Chapter 14, “Assembly Replacement Procedures”, on page 435** in this manual.
3. Remove the MP7 Top Brace. Refer to **Chapter 14, “Assembly Replacement Procedures”, on page 435** in this manual.
4. With AC power connected to the rear of the instrument but without turning it on, leaving it in standby mode, measure the voltage at the top side of R867 of the A7 Midplane board assembly. See **Figure 2-4** for R867 location.

Does the voltage at R867 measure 5 VDC?

If yes:

Proceed to **step 5**.

If no:

Replace the A6 Power Supply assembly.

---

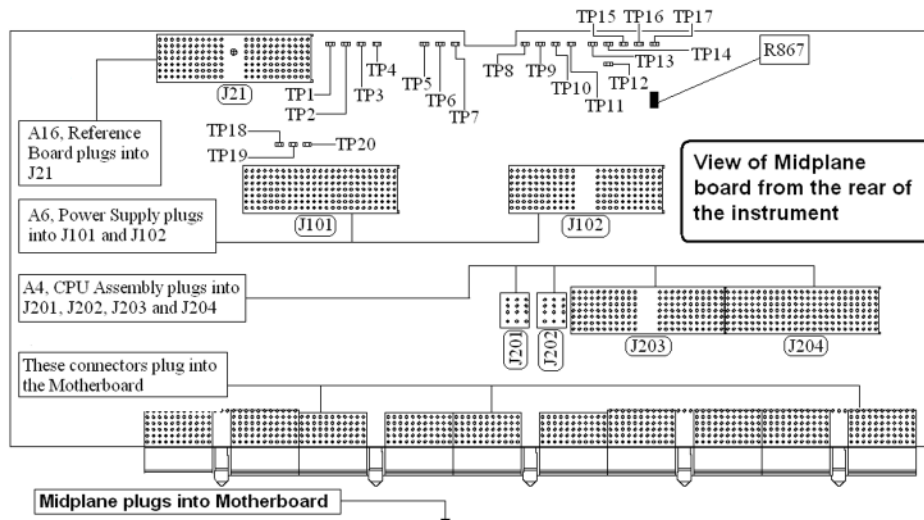
### NOTE

Before replacing the power supply, verify the midplane and motherboard interconnects are mechanically secure.

---

Figure 2-4

A7 Midplane Board - R867



5. While monitoring the voltage at R867, turn the instrument power on by pressing the front panel On/Off button.

Does the voltage at R867 measure 0 VDC?

If yes:

Proceed to **step 6**.

If no:

After verifying that the connections from the front panel On/Off button back to the A4 CPU board are not at fault, replace the A4 CPU board.

6. Do all of the green power supply LEDs along the top of the A7 Midplane board come on?

If yes:

After verifying that the connections from the front panel On/Off button back to the A4 CPU board are not at fault, replace the A4 CPU board.

If no:

Replace the A6 Power Supply assembly.

**NOTE**

Before replacing the power supply, verify the midplane and motherboard interconnects are mechanically secure.

## Fan(s) Are Not Operating

Control of the instrument fans comes from the A6 Power Supply assembly. This signal is routed from the A6 Power Supply through the A7 Midplane board, where there is a test point and LED to monitor the level, and is then routed to the A8 Motherboard where it is filtered before being sent to the Fans. When the Fans do not come on it could be due to any one of these assemblies. This procedure will help to determine which one is the cause.

This procedure assumes that the green Power On LED on the front panel does turn on when the instrument is turned on. If it doesn't, refer to the **“Green Power On LED Does Not Illuminate”** section before proceeding.

1. The instrument fans will only turn on when the instrument is connected to an AC source that has a voltage level and frequency of that specified for the instrument and the front panel On/Off button has been pressed. Before proceeding verify that these requirements are being met. Refer to the instrument rear panel for these requirements.
2. Remove the AC power cord and then remove the instrument cover. Refer to the **Chapter 14, “Assembly Replacement Procedures”, on page 435** in this manual.

3. Are both fans not spinning?

If yes:

Proceed to **step 4**.

If no:

Proceed to **step 6**.

4. Remove the MP7 Top Brace. Refer to **Chapter 14, “Assembly Replacement Procedures”, on page 435** in this manual.
5. Refer to **Figure 2-5**, verify that the Fan LED on the A7 Midplane board is on. Is the Fan LED on?

If yes:

Measure the voltage level at TP1 on the A7 Midplane board. Is the TP1 voltage between +7 and +15 VDC

If yes:

Proceed to **step 6**.

If no:

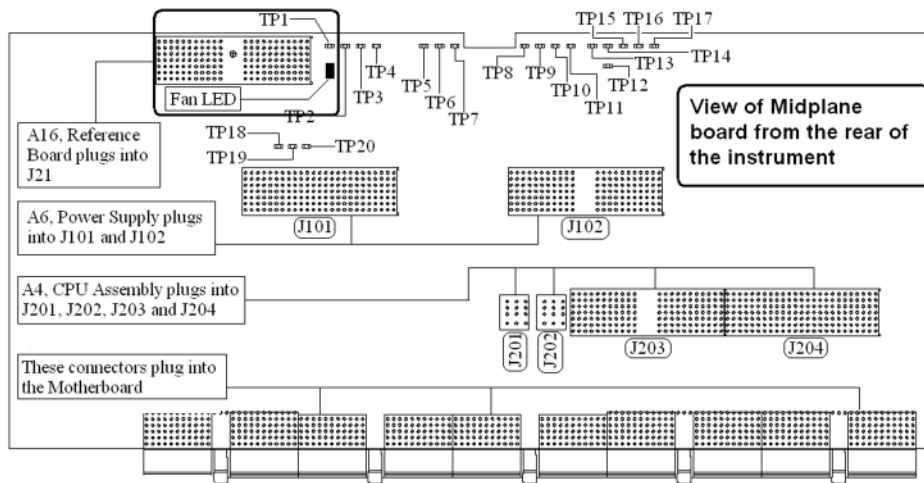
Replace the A6 Power Supply assembly.

If no:

Replace the A6 Power Supply assembly.

**NOTE** Before replacing the power supply, verify the midplane and motherboard interconnects are mechanically secure.

**Figure 2-5** A7 Midplane Board - Fan LED



6. With the instrument turned off, and the AC power cord removed, remove the Fan Assembly including unplugging both fans from the A8 Motherboard. Refer to [Chapter 14, "Assembly Replacement Procedures", on page 435](#) in this manual.
7. Turn the instrument power back on and measure the fan voltage at both of the fan connectors (J6 & J7) on the A8 Motherboard.

Both connectors have three pins. The outer conductors on both connectors are the FAN\_P supply and the center conductors are FAN\_N. The voltage between FAN\_P and chassis ground should be between +7 and +15 VDC on both connectors.

Does the A8 Motherboard fan connector for the fan(s) that do not work have the required voltage level?

If yes:

Replace the fan(s) that is not working

If no:

After verifying that the connections between the A7 Midplane board and the A8 Motherboard are mechanically and electrically secure replace the A8 Motherboard.



## No Agilent Splash Screen Displayed

(Black background with white “Agilent Technologies” text)

A problem of not displaying the Agilent splash screen could be caused by many different things. It could be due to a down power supply, a processor hardware problem, an instrument boot-up process error, a display section failure, etc.

This procedure assumes that the green Power On LED on the front panel does turn on when the instrument is turned on. If it doesn't, refer to the **“Green Power On LED Does Not Illuminate”** section before proceeding.

1. Remove the AC power cord and then remove the instrument cover. Refer to **Chapter 14, “Assembly Replacement Procedures”**, on page 435 in this manual.
2. Remove the MP7 Top Brace. Refer to **Chapter 14, “Assembly Replacement Procedures”**, on page 435 in this manual.
3. With the AC power applied and the On/Off button turned on, verify that all of the power supply voltages are at their proper level. This can easily be done by viewing the power supply LEDs on the back side of the A7 Midplane board. See **“A7 Midplane Assembly Troubleshooting”** on page 327 of this manual.

Are all of the power supply voltages at the proper level?

If yes:

Proceed to **step 4**.

If no:

After verifying that the connections between the A6 Power Supply, the A7 Midplane board, and the A8 Motherboard are all mechanically and electrically secure, replace the A6 Power Supply assembly.

4. Connect an external VGA monitor to the rear panel display output and cycle power on the analyzer. If power is not cycled, the CPU might not recognize that an external monitor is connected.

Does the external monitor display the correct information?

If yes:

Proceed to the **“Troubleshooting a Blank Display”** section in this chapter.

If no:

Replace the A4 CPU Board assembly.

## Instrument Hangs at the Agilent Splash Screen

A problem of the instrument hanging at the Agilent splash screen could be caused by many different things. It could be due to a down power supply, a processor hardware problem, an instrument boot-up process error, etc.

1. Remove the AC power cord and then remove the instrument cover. Refer to [Chapter 14, “Assembly Replacement Procedures”, on page 435](#) in this manual.
2. Remove the MP7 Top Brace. Refer to [Chapter 14, “Assembly Replacement Procedures”, on page 435](#) in this manual.
3. With the AC power applied and the On/Off button turned on, verify that all of the power supply voltages are at their proper level. This can easily be done by viewing the power supply LEDs on the back side of the A7 Midplane board. See [“A7 Midplane Assembly Troubleshooting” on page 327](#) of this manual.

Are all of the power supply voltages at the proper level?

If yes:

After verifying that the connections from the A7 Midplane board to the A4 CPU board are not at fault, replace the A4 CPU board.

If no:

After verifying that the connections between the A6 Power Supply, the A7 Midplane board, and the A8 Motherboard are all mechanically and electrically secure, replace the A6 Power Supply assembly.

## PCI Enumeration Error

When the instrument is first booting up it runs some BIOS level self tests, one of which is that of the devices on the PCI bus. If there is a problem with a device on the PCI bus a “PCI enumeration” error may be seen on the boot screen. Since the only assembly connected to the PCI bus, other than the A4 CPU board, is the A3 Digital IF assembly, try removing this assembly and rebooting the instrument to see if the error goes away. Of course, you will have other error messages due to this assembly being missing, but this will allow you to isolate this particular error.

## Instrument Cannot Completely Load or Run the Operating System

A problem of the instrument not loading the operating system can be caused by a few different things. It could be due to a down power supply, a processor hardware problem, an instrument boot-up process error, corrupt hard drive, etc.

This procedure assumes that the instrument can get past the Agilent splash screen at power on. If it doesn't, refer to the **“Instrument Hangs at the Agilent Splash Screen”** section before proceeding.

1. Verify that there are no external USB storage devices connected to the instrument.
2. Does the instrument get far enough along in the boot process to run the “Agilent Recovery System”?

If yes:

Run the “Agilent Recovery System” by referring to the **“Disk Drive Recovery Process” on page 312**. If this does not correct the problem replace the A5 Hard Disk Drive.

If no:

Replace the A5 Hard Disk Drive.

## Troubleshooting a Blank Display

This section is intended to troubleshoot a display system problem that would cause the internal LCD to be blank. It is assumed that the rest of the instrument is booting up and functioning properly. To determine if the problem is an internal display issue only, connect an external VGA monitor to the rear panel display output. If the rear panel display output is also not working go to the **“No Agilent Splash Screen Displayed”** section in this chapter.

Once it has been determined that the rest of the instrument appears to be functioning properly there are a few possible problems that could be causing the display to be blank. They are:

- An LCD Backlight inverter or DC-DC converter problem
- A video signal path integrity problem
- A video controller / LCD problem

## Verify LCD Backlight Functionality

There are two backlights within the LCD assembly, one across the top and one across the bottom. If only one of the backlights has burnt out, the other will still function. Considering this fact, as well as the fact that the expected life span of the backlights is much longer than the LCD itself, it is not very likely that the backlights themselves would cause a completely blank display.

To determine if a blank display problem is backlight related:

1. Remove the AC power cord and then remove the instrument cover. Refer to [Chapter 14, "Assembly Replacement Procedures"](#), on page 435 in this manual.
2. Remove the MP7 Top Brace. Refer to [Chapter 14, "Assembly Replacement Procedures"](#), on page 435 in this manual.
3. Turn the instrument on and allow enough time for it to completely boot-up.
4. Shine a bright light at the display and look closely for the expected information (a large flashlight should work). Since most of the display section of the screen has a black background you will need to look at either the area next to the softkeys or the area across the top of the screen, since these sections will have the largest areas of lighter information in them.
5. Can the expected display information now be seen?

If yes:

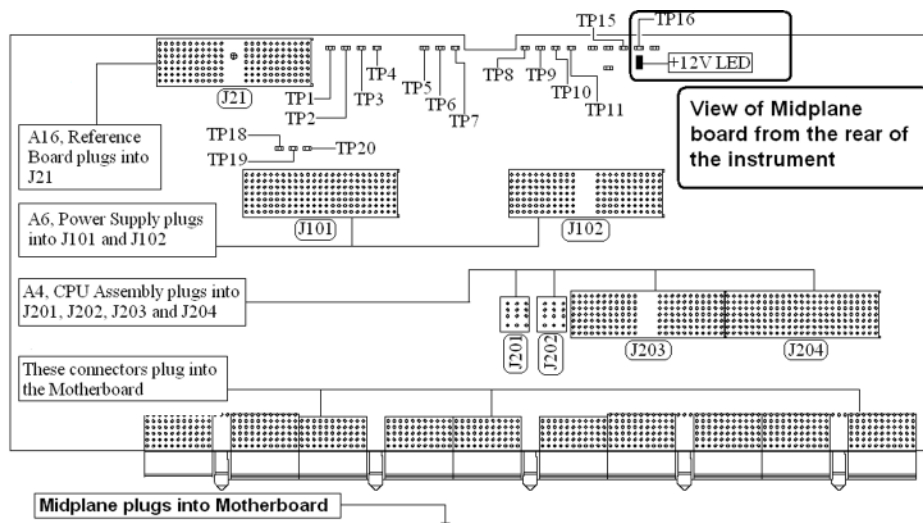
The problem is backlight related. Proceed to [step 6](#).

If no:

The problem is not backlight related. Skip to ["Verify Video Signal Path Integrity"](#).

6. Refer to **Figure 2-6**, verify that the +12D VDC power supply is on.

**Figure 2-6** A7 Midplane Board +12D LED



Is the +12D backlight supply voltage LED on?

If yes:

Proceed to **step 7**.

If no:

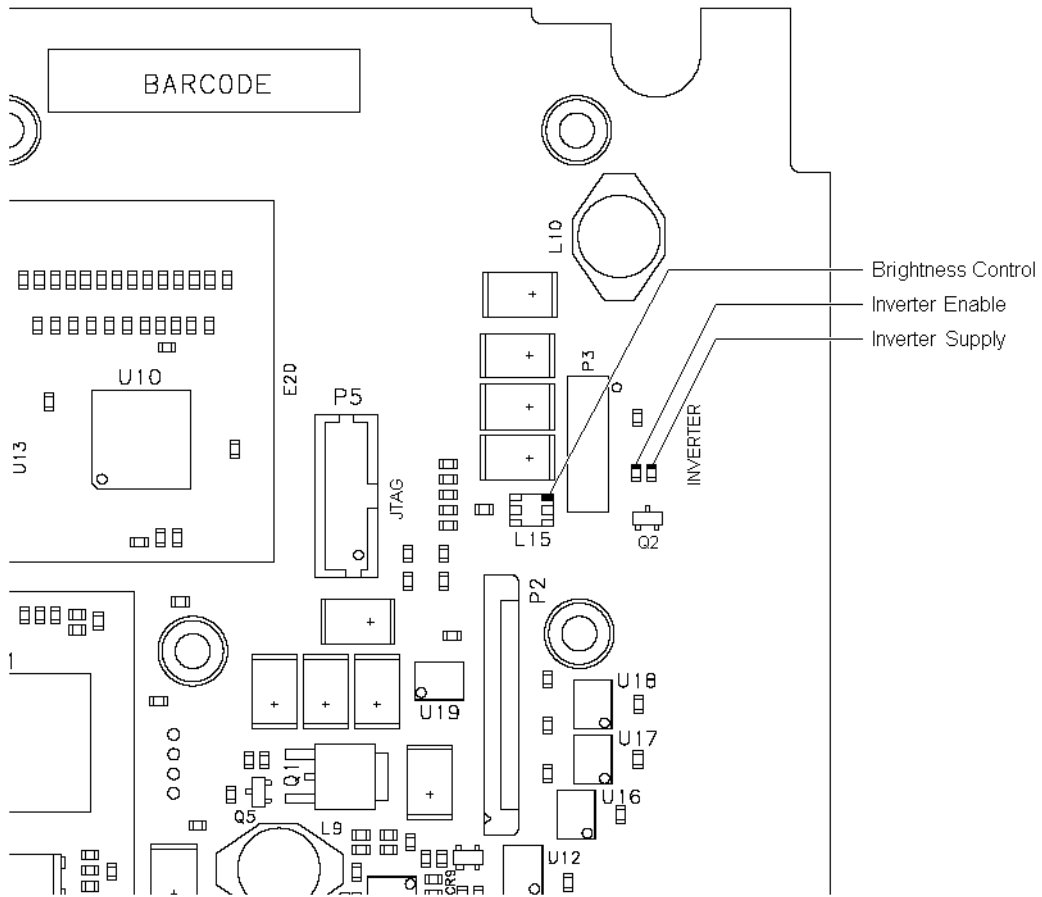
Replace the A6 Power Supply assembly.

7. With the instrument turned off remove the 8 screws that attach the front panel assembly to the instrument chassis.
8. Without disconnecting any of the cables carefully lay the front panel assembly face down on the work surface.
9. Refer to **Figure 2-7**, verify the 3 voltage levels listed in **Table 2-1** are correct.

**NOTE**

The instrument does have a screen saver which can disable the display backlight after a predefined period of time. If there is any question as to whether or not this has been set by the user prior to the current failure, and the "Inverter Enable" voltage measures too low, press a front panel key and see if the voltage level increases to the expected level.

**Figure 2-7** A1A2 Front Panel Interface Board LCD Backlight Inverter Control Voltages



**Table 2-1** Expected Backlight Inverter Control Voltage Levels

Signal	Expected Voltage
Brightness Control	0 to 3 VDC <sup>a</sup>
Inverter Enable	>6 VDC
Inverter Supply	+12 VDC

a. On newer analyzers, the backlight is a string of LEDs, rather than a fluorescent tube. The brightness control voltage for the LEDs ranges from 0 to 2.5VDC, rather than 0 to 3VDC. If the A1A2 Front Panel Interface board installed is either W1312-60042 or N9020-60033, expect this voltage to range from 0 to 3VDC.

**10. Are all of the 3 voltage levels within their expected ranges?**

If yes:

Replace the A1A4 LCD Inverter or DC-DC Converter board.

If no:

Replace the A1A2 Front Panel Interface board.

## Verify Video Signal Path Integrity

The video controller is located on the A4 Processor assembly and is routed to the front panel LCD through a few interconnections. These interconnections are:

- A4 Processor assembly to A7 Midplane Board
- A7 Midplane Board to A8 Motherboard assembly
- A8 Motherboard assembly to A1A2 Front Panel Interface assembly via W1 ribbon cable
- A1A2 Front Panel Interface to A1A3 LCD via A1W1 flex-circuit

If all of these connections are properly made and none of the cables are damaged proceed to **“Video Controller / LCD Troubleshooting”**.

## Video Controller / LCD Troubleshooting

The video controller is located on the A4 Processor assembly. The video signals that the controller outputs are LVDS. As described above, these signals are routed to the LCD via the A7 Midplane Board, A8 Motherboard, and A1A2 Front Panel Interface board.

On the A1A2 Front Panel Interface board the LVDS signals are buffered and then sent to the LCD via the A1W1 Flex circuit.

The most likely cause for a video problem is the A4 Processor assembly; however it could be the result of a defective LCD.

## Initializations Did Not Complete

During the initialization of the MXA Signal Analyzer Application the following messages will be displayed on the application splash screen:

- Checking for required services (1 of 7)
- Initializing License Services (2 of 7)
- Initializing Hardware (3 of 7)
- Initializing Data Services (4 of 7)
- Initializing SCPI Services (5 of 7)
- Initializing Message Services (6 of 7)
- Initializing Front Panel EEPROM Services (7 of 7)

If there is a problem with any of these initializations not completing or causing an error message to be displayed refer to the instrument Event Log. This can be accessed by using an external USB keyboard and mouse and selecting Start, Run, enter Eventvwr.exe, and select OK.

Once the Event Viewer comes up, look under SA for the latest error entries. Double-click on the entries to view further details, which should give you some idea of what the problem is.

## Fails an Initial Alignment

While the application software is loading the instrument will perform a total of 24 internal alignments before the analyzer begins to sweep. The alignment numbers, descriptions and related hardware are described in the [Table 2-2](#).

Table 2-2 Initial Alignments

Alignment Description	Most Probable Hardware Failure	Related Hardware
<b>Pre-tune 1st L.O. DAC</b>	A14 L.O. Synthesizer	A16 Reference board is not providing correct 4.8 GHz signal
<b>Final Tune DAC Setting</b>	A14 L.O. Synthesizer	A16 Reference board is not providing correct 4.8 GHz signal
<b>VCXO Tuning Curve</b>  (Power up alignment only) Measures the tuning voltage for the 100 MHz VCO at a number of different frequencies. Uses 10 MHz internal reference	A16 Reference	
<b>VCXO Loop Band width</b>  Adjusts gain of the PLL loop amplifier. Uses the 10 MHz internal reference	A16 Reference	
<b>2nd LO Tuning Curve</b>  (Power up alignment only) Measures the tune voltage for the 4800 MHz VCO at a number of different frequencies. Uses the 10 MHz internal reference	A16 Reference	
<b>2nd LO Loop Band width</b>  Adjusts gain of the PLL loop amplifier. Uses the 10 MHz internal reference.	A16 Reference	
<b>Dither Level Algorithm</b>  (4 measurements)	A3 Digital IF	



Boot Up and Initialization Troubleshooting  
Potential Problems During Boot Process

Table 2-2 Initial Alignments

Alignment Description	Most Probable Hard ware Failure	Related Hard ware
<p><b>AIF LC Wide Prefilter Passband Tuning Algorithm</b></p> <p>Adjusts the LC prefilter centering with the prefilter BW set to about 1.12 MHz.</p> <p>Uses 322.5 MHz Comb Calibrator on the A-IF.</p>	A2 Analog IF	
<p><b>AIF LC Wide Prefilter Passband Fine Tuning Algorithm</b></p>	A2 Analog IF	
<p><b>AIF LC Narrow Prefilter Passband Tuning Algorithm</b></p> <p>Adjusts the LC prefilter centering with the prefilter BW set to about 413 kHz.</p> <p>Uses 322.5 MHz Comb Calibrator on the A-IF.</p>	A2 Analog IF	
<p><b>AIF LC Narrow Prefilter Passband Fine Tuning Algorithm</b></p>	A2 Analog IF	
<p><b>AIF Xtal Wide Prefilter Passband Tuning Algorithm</b></p> <p>Adjusts Centering, symmetry and dip of the crystal prefilter BW set to about 80 kHz</p> <p>Uses 322.5 MHz Comb Calibrator on the A-IF</p>	A2 Analog IF	A3 Digital IF or A16 Reference
<p><b>AIF Xtal Narrow Prefilter Passband Tuning Algorithm</b></p> <p>Adjusts Centering, symmetry and dip of the crystal prefilter BW set to about 13 kHz</p> <p>Uses 322.5 MHz Comb Calibrator on the A-IF</p>	A2 Analog IF	
<p><b>AIF Variable Gain Algorithm</b></p> <p>The Gain of the Analog IF System is measured and compared with the ideal gain value. Several conditions are tested, Dither on/ dither off, A-IF prefilter in and bypassed, alias filter set wide and narrow.</p> <p>Uses 322.5 MHz Comb Calibrator on the A-IF</p>	A2 Analog IF	

Table 2-2 Initial Alignments

Alignment Description	Most Probable Hard ware Failure	Related Hard ware
<p><b>AIF Step Gain Algorithm</b></p> <p>Measures the relative gain of the IF for high gain (10 dB) versus the low gain (0 dB) paths. In normal instrument operation these two states can be controlled by the user interface key called "Swept IF Gain".</p> <p>Uses the Comb calibrator on the A-IF</p>	A2 Analog IF	
AIF 140 Variable Gain Alignment Algorithm (Option B85, B1A, or B1X)	A25 Wideband A-IF	
<p><b>LO Power Alignment Algorithm</b></p> <p>Measure max LO power then backs off for each band</p>	A13 Front End Assembly or A15 Front End Controller	
<p><b>AIF Variable Attenuator Algorithm</b></p> <p>Measures the gain in all settings of the A-IF 1 dB step attenuator. A reference power is measured with atten 4 dB</p> <p>The Comb calibrator on A-IF is used to provide a CW signal.</p>	A2 Analog IF	
<p><b>Mechanical Attenuator Algorithm</b></p> <p>Measures the attenuation of all DC coupled, and one AC coupled (10 dB) settings of the RF input attenuators.</p> <p>Reference atten setting is 10 dB</p>	A9 and A10 RF Input Attenuators	50 MHz calibrator on A16 Reference
<p><b>Electrical Attenuator Algorithm</b></p> <p>Each setting from 0 to 24 dB in steps of 1 dB is measured. The reference condition is electrical attenuator set to 0 dB and RF input attenuators set to 10 dB. (Option EA3)</p>	A13 Front End	50 MHz calibrator on A16 Reference.
<p><b>Electrical Attenuator Tail Algorithm</b></p> <p>Attenuation set to 0 dB (Option EA3)</p>	A13 Front End	
<p><b>AIF 140 Variable Attenuator Algorithm</b></p> <p>Ref power at atten 12 dB (Option B85, B1A, or B1X)</p>	A25 Wide band A-IF	
<p><b>DIF 40 Variable Attenuator Algorithm</b></p> <p>Ref power at atten 21 dB (Option B40)</p>	A3 Digital IF	

Table 2-2 Initial Alignments

Alignment Description	Most Probable Hard ware Failure	Related Hard ware
<p><b>Narrow Band Step Cal Adjustment Alignment Algorithm</b></p> <p>Recalled adjustment from calibration file. (Option B40)</p>	Alignment signal originates on A3 D-IF, then goes through A16 Reference, through A13 Front End, through A2 Analog IF, and back to A3 Digital IF.	
<p><b>DIF 40 Step Cal Adjustment Alignment Algorithm</b></p> <p>Recalled adjustment from calibration file. (Option B40)</p>	Since this is wide band alignment done for 40 MHz BW signal path, A2 Analog IF is not included in the signal path.	
<b>Narrow Band Step Cal Alignment Algorithm</b>		
<b>DIF 40 Step Cal Alignment Algorithm</b> (Option B40)		
AIF 160 Band 0 Chirp Cal Alignment Algorithm (Option B85, B1A, B1X)	A25 Wide band A-IF	
AIF 160 $\mu$ W Band Chirp Cal Alignment Algorithm (Option B85, B1A, B1X)	A25 Wide band A-IF	
<p><b>E Cal Path System Gain Algorithm</b></p> <p>Measures the amplitude error of the low band signal path by injecting the 50 MHz E-Cal signal into the A13 Front End assembly. The E-Cal signal originates on the A16 Reference assembly.</p>	Signal path from A13 Front End to A3 Digital IF	A16 Reference may not be providing 50 MHz E-Cal
<p><b>Low Band Nominal Path System Gain Algorithm</b></p> <p>Aligns low band (3 Hz to 3.6 GHz path) with preamp and electronic attenuator OFF. Dependent on successful E-Cal alignment.</p> <p>Input attenuators set to 10 dB and DC coupled.</p>	A13 Front End	50 MHz calibrator on A16 Reference. A9 and A10 Input attenuators
<p><b>Low Band Preamp Path System Gain Algorithm</b></p> <p>Aligns low band (3 Hz to 3.6 GHz path) with preamp ON.</p> <p>Input attenuator set to 20 dB. (Options P03, P07, P32, P44)</p>	A13 Front End	50 MHz calibrator on A16 Reference. A9 and A10 Input attenuators

Boot Up and Initialization Troubleshooting  
Potential Problems During Boot Process

Table 2-2 Initial Alignments

Alignment Description	Most Probable Hard ware Failure	Related Hard ware
<p><b>Low Band Elec Atten Path System Gain Algorithm</b></p> <p>Aligns low band with electronic attenuator in the signal path and set to 0 dB. (Option EA3)</p>	A13 Front End	<p>50 MHz calibrator on A16 Reference.</p> <p>A9 and A10 Input attenuators</p>
<p><b>Preselector Two Point Tuning Algorithm</b></p> <p>Aligns the YTF preselector centering near the maximum and minimum frequency points of the YTF.</p> <p>Uses the high band preamp noise as stimulus signal.</p>	<p>A12 YTF Preselector or A15 Front End Controller or All Low Band</p>	A13 Front End
<p><b>High Band Nominal Path System Gain Algorithm</b></p>	Anything in Band 1 signal path	4800 MHz calibrator on A16 Reference
<p><b>High Band Preamp Path System Gain Algorithm</b></p> <p>Measures change in signal level with high band preamp turned ON and OFF. Input attenuator set to 30 dB. (Options P07, P32, P44)</p>	A11 Low Band Switch	<p>4800 MHz calibrator on A16 Reference</p> <p>A9 and A10 Input attenuators</p> <p>A15 Front End Controller</p>
<p><b>High Band Preselector Bypass Path System Gain Algorithm</b></p> <p>A12 YTF Preselector is bypassed and amplitude of 4800 MHz calibrator measured. System gain is then computed. (Option MPB)</p>	SW1 and SW2, coax switches and cabling (Options 503, 508, 513, 526)	<p>A15 Front End Controller</p> <p>4800 MHz calibrator on A16 Reference</p> <p>A9 and A10 Input attenuators</p>
<p><b>High Band Preselector Bypass Preamp Path System Gain Algorithm</b> (Option MPB)</p>	A11 Low Band Switch SW1, SW2, or SW4 Preselector Bypass Switches	
<p><b>Burst Carrier Trigger Curve Fit Algorithm</b></p> <p>Detects the level of the signal envelope before filtering at the 22.5 MHz IF, and compares that detected level against the trigger threshold DC level.</p>	A2 Analog IF	
<b>Trigger Interpolation</b>	A3 Digital IF	
<b>DIF 25 Pulse Stretcher Alignment Algorithm</b>	A3 Digital IF	
<p><b>DIF 40 Pulse Stretcher Alignment Algorithm</b></p> <p>Adjusts time between trigger and clock signal. (Option B40)</p>	A3 Digital IF	

Table 2-2 Initial Alignments

Alignment Description	Most Probable Hardware Failure	Related Hardware
WBDIF Pulse Stretcher Alignment Algorithm (Option B85, B1A, or B1X)	A26 WBDIF	
DC Offset Alignment Algorithm (Option BBA)	A19 BBIQ Main A18 BBIQ Interface	

Using an external USB keyboard and mouse you can also access the alignment history, which can be found in a text file at:

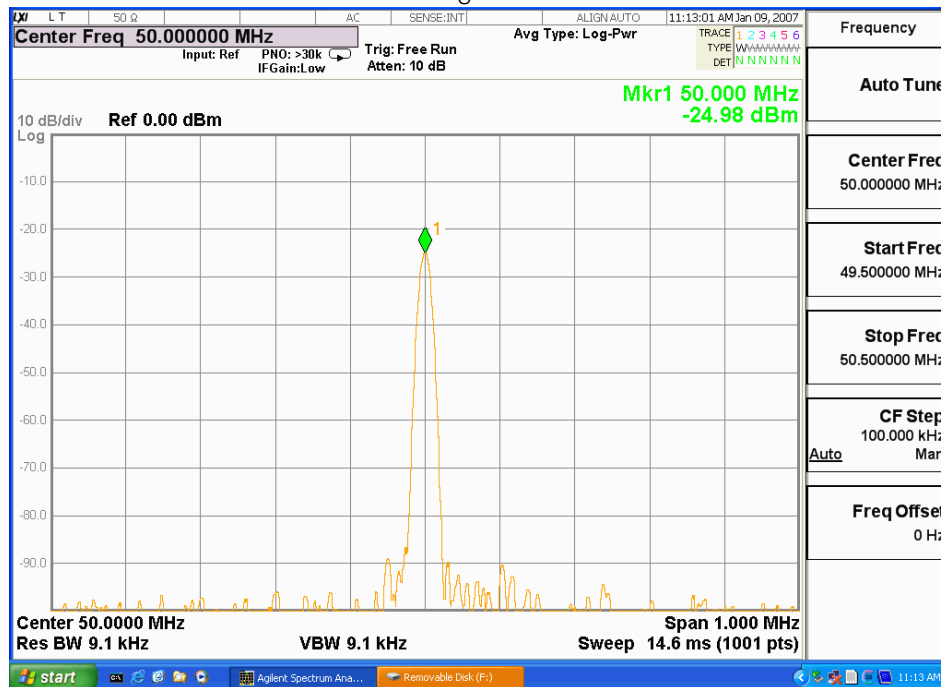
C:\ProgramFiles\Agilent\SignalAnalysis\Physics\AlignmentHistory.txt

You will find the most current alignment information at the bottom of this file. Look for the failed alignments and troubleshoot the Related Hardware based on the information provided in **Table 2-2**.

## Signal Level Verification

### Signal Level Problem with Input Frequencies < 3.6 GHz

Measure the 50 MHz RF calibrator signal level by pressing **Input/Output, RF Calibrator, 50 MHz**. Now press **Freq, 50 MHz, SPAN, 1 MHz, Peak Search**. If the analyzer is functioning correctly in low band, the 50 MHz calibrator level should be  $-25 \text{ dBm} \pm 2 \text{ dB}$ . See the figure below.



Is the signal level correct?

If yes:

The analyzer low band path is functioning properly at least at 50 MHz.

If no:

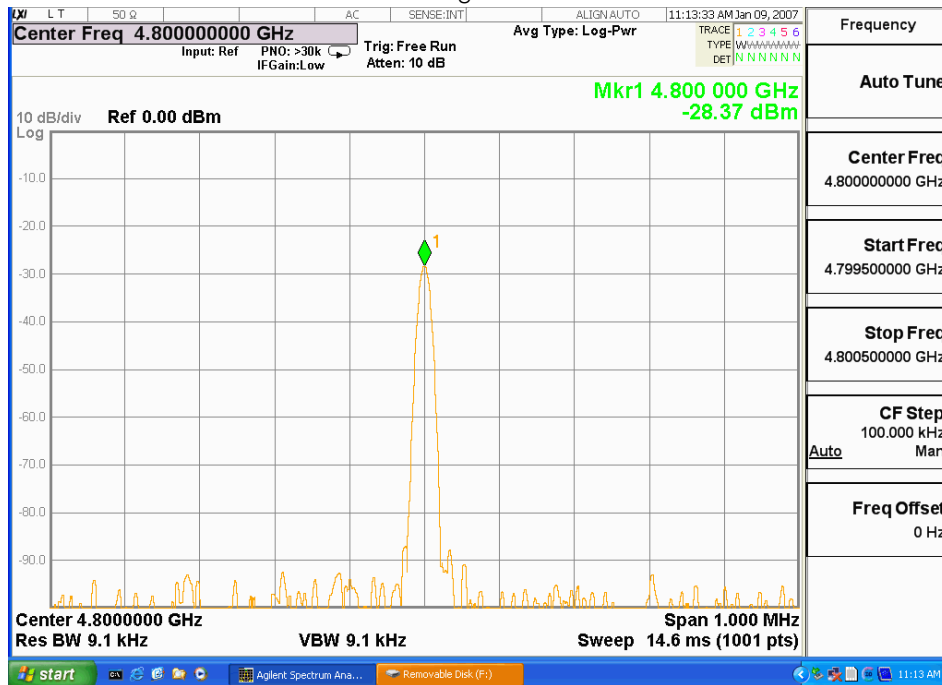
Refer to **Chapter 4, “RF Section Troubleshooting”** in this manual.

#### NOTE

It is possible that other input frequencies < 3.6 GHz could have an amplitude problem even though the 50 MHz calibrator is within tolerance. Using the internal RF calibrator provides a quick check of the low band path.

## Signal Level Problem with Input Frequencies > 3.6 GHz

Measure the 4.8 GHz RF calibrator signal level by pressing **Input/Output**, {**RF Calibrator**}, **4.8 GHz**. Now press **Freq**, **4.8 GHz**, **SPAN**, **1 MHz**, **Peak Search**. If the analyzer is functioning correctly in high band, the 4.8 GHz calibrator level should be  $-28 \text{ dBm} \pm 2 \text{ dB}$ . See the figure below.



Is the signal level correct?

If yes:

The analyzer high band path is functioning properly at least at 4.8 GHz.

If no:

Refer to **Chapter 4, “RF Section Troubleshooting”** in this manual.

### NOTE

It is possible that other input frequencies > 3.6 GHz could have an amplitude problem even though the 4.8 GHz calibrator is within tolerance. Using the internal RF calibrator provides a quick check of the high band path.

Boot Up and Initialization Troubleshooting  
Signal Level Verification



## 3 Instrument Messages

### Introduction

The Error and Status messaging system of the instrument reports events and conditions in a consistent fashion, as well as logging and reporting event history.

#### Event vs. Condition Messages

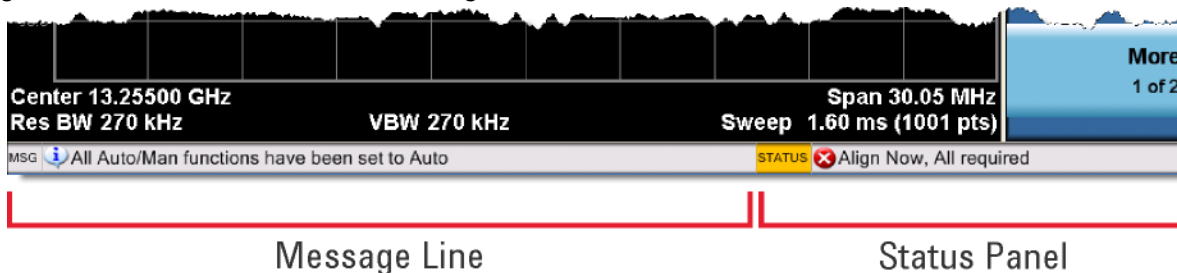
- An Event is simply a message indicating that something has happened. Events are sub-divided according to their severity, into Error, Warning or Advisory categories. The sub-divisions are described in more detail in the section **“Event and Condition Categories” on page 74**.

Event messages appear in the Message Line at the bottom left of the instrument’s display window, as shown in **Figure 3-1** below.

- A Condition is a state of the instrument, which is characterized by a Detection event and a Clearing event. Conditions may be Errors or Warnings.

Condition messages appear in the Status Panel at the bottom right of the instrument’s display screen, as shown in **Figure 3-1** below.

Figure 3-1 Instrument Message Line & Status Panel



## Event and Condition Categories

The three categories of severity are described below, for both Events and Conditions.

### Errors



Error messages appear when a requested operation has failed. (For example, “Detector not available”, “File not saved”.) Error messages are often generated during remote operation when an invalid programming command has been entered. (For example, “Undefined header”.)

Some errors are conditions rather than single events. They exist for a period of time, so they have associated “Detected” and “Cleared” events. (For example, “LO Unlocked” or “External reference out of range”.)

Error messages appear in the Status Panel at the bottom of the display. A message remains until you press a key, or another message is displayed in its place.

Error messages are logged in the error queues. If the error is a condition, both the Detected and Cleared events are logged.

---

### Warnings



Warning messages appear when a requested operation has completed successfully, but there are modifications and/or side effects. (For example, if you requested too high a stop frequency, then “Data out of range” is displayed and the analyzer sets itself to the highest available stop frequency.)

Some warnings are conditions rather than single events. They exist for a period of time, so they have a “Detected” event and a “Cleared” event. (For example, if you set the sweep time too fast for a measurement to meet the instrument specifications then the “Meas Uncal” message is displayed until you slow down the sweep time.)

Warning messages appear in the Status Panel at the bottom of the display. The message remains until you press a key, or another message is displayed in its place.

Warnings are logged in the error queues. If the warning is a condition, both the Detected and Cleared event messages are logged.

## Advisories



Advisory messages tell the front panel user some useful information. (For example, “File saved successfully” or “Measuring the fundamental”.)

Advisory messages appear in the Status Panel at the bottom of the display. The message remains until you press a key, or another message is displayed in its place.

Advisory messages are not logged in the error queues.

Grayout messages are a special type of Advisory, which appear when you attempt to access a function that is not available. This could be a grayed out front panel key, or an inappropriate SCPI command. There are two types of grayout messages: Benign and Forced.

1. **Benign:** the requested function is not available because it does not make sense with the current instrument settings. Changing it does not affect the current measurement. (For example, setting the number of FFTs/Span when you are not in the FFT mode.)

A benign grayout gives an Advisory type of message only when the front panel key is pressed.

The requested function cannot be changed from the front panel, but it can be changed remotely.

2. **Forced:** the requested function is not available either because changing it would cause an invalid measurement, or because of hardware limitations, or because the selection conflicts with other settings. (For example, selecting the electrical attenuator when the frequency span includes frequencies above 3.6 GHz.)

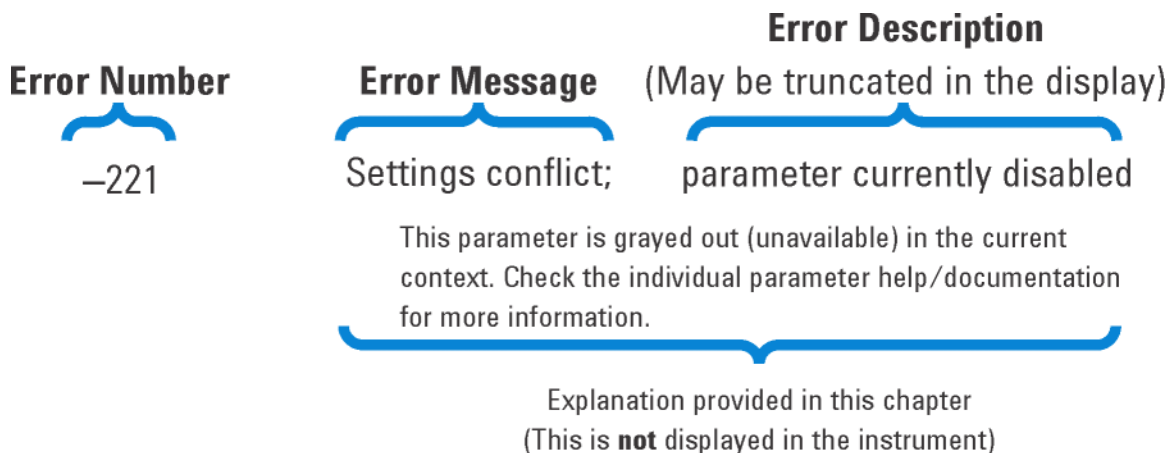
A forced grayout function cannot be changed either from the front panel or remotely. It generates a special type of Advisory message. It also only appears on the front panel when the key is pressed. Remotely, the message will appear in the event queue as a warning “-221, Settings conflict; <conflict description>”.

## Event Message Format

The event messages are listed in numerical order according to their message number. Advisory messages do not have numbers, and are listed in alphabetical order.

An explanation is included with each error to further clarify its meaning. Some errors are specified in industry standards, and may include references to Section 21.8 of the 1999 SCPI Syntax & Style Standard (<http://www.ivifoundation.org/docs/scpi-99.pdf>).

Figure 3-2 Error Message Example



## Event Queues

There are several different event queues that are viewed/queried and managed separately. Note that Conditions are logged in the queues as pairs of events: a “Detected” event and a corresponding “Cleared” event.

Table 3-1 Event Queue Types

Front Panel Status	Error messages can be viewed by pressing, <b>System, Show Errors, Status</b> . The Status screen shows error conditions that currently exist. When an error event is caused by a command sent over a remote interface, the resulting messages are logged in the queue for that interface. For convenience, they are also logged in the front panel queue.
Front Panel History	Error messages can be viewed by pressing, <b>System, Show Errors, History</b> . The History screen shows all the error events that have occurred since the instrument was turned on, with a maximum of 100 messages. When an error situation is caused by a command sent over a remote interface, the resulting messages are logged in the queue for that interface. For convenience, they are also logged in the front panel queue.
Remote interfaces (GPIB/LAN)	When an error event is caused by a command sent over a remote interface, the resulting messages are output to the queue for that interface. To return an error, you must query the queue for that interface. An error event that is caused by a front panel action is not reported to any remote interface queue. However, a status condition is usually caused by an internal event that is not related to a particular interface, so the Detected/Cleared events for status conditions are reported to all the error queues.

Table 3-2 Characteristics of the Event Queues

Characteristic	Front-Panel Status	Front-Panel History	Remote Interfaces (GPIB/LAN)
Capacity (maximum number of messages)	100	100	100

Table 3-2 Characteristics of the Event Queues

Characteristic	Front-Panel Status	Front-Panel History	Remote Interfaces (GPIB/LAN)
Overflow Handling	Circular (rotating). Drops oldest error as new error comes in.	Circular (rotating). Drops oldest error as new error comes in.	Linear, first-in/first-out. Replaces newest error with: -350, Queue overflow
Viewing Entries	Press: <b>System, Show Errors, Status</b>	Press: <b>System, Show Errors, History</b>	Send SCPI query to the desired interface.  SYSTem:ERRor?
Clearing the Queue	Press: <b>System, Show Errors, Clear Error Queue</b>  Clears the errors in all the queues.	Press: <b>System, Show Errors, Clear Error Queue</b>  Clears the errors in all the queues.	Send *CLS command to the desired interface.  Clears errors in the queue for this particular interface only.

Table 3-3 Summary of Event Reporting Modes

Event Type	SCPI Error Queues	Front Panel History Queue	Status Panel Display
Error Event	Logged	Logged	Displayed in Message Line
Warning Event	Logged	Logged	Displayed in Message Line
Advisory Event	Logged	Logged	Displayed in Message Line
Error Condition Detected	Logged	Logged	Displayed in Status Line
Error Condition Cleared	Logged		
Warning Condition Detected	Logged	Logged	Displayed in Status Line
Warning Condition Cleared	Logged		
Grayout Advisory (Benign)	Not logged	Logged	Displayed in Message Line
Grayout Advisory (Forced)	See note <sup>a</sup>	Logged	Displayed in Message Line

a. Not logged, unless the cause of the Advisory was remotely generated, in which case a Warning message, type -221, is logged.

## Advisory Messages

An advisory is simply a message that lets you know something useful; for example “File saved successfully” or “Measuring fundamental.” Operation completion and running status indications are common types of advisories. Advisories have no number and are not logged in the error queue.

Advisories include gray-out “settings conflict” errors. These gray-outs are benign (that is, changing them has no impact on the current measurement).

Advisories are event-type errors only. They are never conditions.

Message	Description/Correction Information
All Auto/Man functions have been set to Auto	Message generated by pressing the Auto Couple front-panel key
Allowable Center Frequency exceeded for the current span	When rotating the knob or step up/down keys to change the Center frequency, the value of the Span is kept constant. Therefore, the center frequency is limited by the frequency range of the instrument
Allowable Span exceeded for the current center frequency	When rotating the knob or step up/down keys to change the Span, the value of the Center frequency is kept constant. Therefore, the span is limited by the frequency range of the instrument
Allowable Start Frequency exceeded for the current span	When rotating the knob or step up/down keys to change the Start frequency, the value of the Span is kept constant. Therefore, the start frequency is limited by the frequency range of the instrument
Allowable Stop frequency exceeded for the current span	When rotating the knob or step up/down keys to change the Stop frequency, the value of the Span is kept constant. Therefore, the stop frequency is limited by the frequency range of the instrument
Already in Single, press Restart to initiate a new sweep or sequence	The instrument is already in the single state. If you want to start a new sweep or sequence, press the <b>Restart</b> key instead
Auto sweep time rules do not apply in FFT sweeps	FFT sweeps do not use the auto sweep time rules, so the rules setting cannot be changed from the front panel. The setting can be changed remotely and it will have no effect on the current operation unless the analyzer is switched out of FFT sweeps
Band Adjust has no effect on a Fixed marker	If a Marker is a Fixed type marker, the marker's value does not change from when it first became fixed. So you cannot change the band of a fixed marker
Band Adjust has no effect with Mkr Function Off	If Marker Function is off, changing the band has no effect
Band-pass filter set to OFF	Turning on any high-pass or low-pass filter turns off band pass filters
Cal Cancelled; Calibration data cleared	User has canceled the cal either directly or indirectly by changing the setup parameters. The current cal data has been erased. Perform a new user cal to obtain calibrated results again

Instrument Messages  
Advisory Messages

Message	Description/Correction Information
Cal Invalid: meas freq pt(s) > 3.6GHz are > 50MHz from existing Cal pts	When freq points being measured are above 3.6 GHz and a calibration has been successfully performed, and the number of points are changed, the new points are required to be within 50 MHz of the current cal points or the preselector optimize frequencies become inaccurate and the whole cal needs to be invalidated. Interpolation of the cal can only be performed if the new freq points are within 50 MHz of the cal points. To overcome this problem, change the number of freq points back to match cal points or perform another user cal
Carrier power is too low for optimum dynamic range.	For better dynamic range, transmit band spur measurements require >10 dBm signal power at the RF input port
Connecting to source...	The External Signal Generator is being interrogated via SCPI, to see whether it is suitable for the instrument to control. Please wait until complete before pressing any buttons
Demod Time is not available in Zero Span	The Demod Time function is not available in zero span because in zero span we are <b>always</b> demodulating
Detector <X> changed due to physical constraints	You have selected more detectors than the instrument hardware can implement. An existing detector selection has been changed to allow the current detector choice to be selected.  <X> indicates the trace number for which the detector was changed
Dynamic range is not optimum. Set AUTO RF input.	
Exp. Averaging not available when AUTO PhNoise is active.	
FFT Width is not settable unless Sweep Type is set to FFT	You must select the FFT sweep type before you can set the FFT Width
File <filename> saved	The file save operation executed successfully
Filter BW function is only available for Gaussian filter type	Flattop and CISPR/MIL filters have defined shapes that cannot be altered. Only the Gaussian filter type allows filter bandwidth definition changes
Fixed LO freq should be greater than RF Stop freq	The setup frequencies break the rules for a downconverter measurement. The measurement will still run, but check setup frequencies are correct before continuing. The LO fixed freq should be greater than the RF freq's for an LSB or DSB (for DSB measurements the setup uses LSB values) downconverter setup. Use the graph icon on the DUT setup form to clarify the setup required
Freq Scale Type=Log is not available in Zero Span	Logarithmic scaling cannot be used for time domain sweeps (0 Hz span)

<b>Message</b>	<b>Description/Correction Information</b>
<b>Frequency Hopping enabled, waiting for valid burst</b>	The demodulated burst type has not been found in the originally demodulated slot location within the frame
<b>Frequency menu has changed to reflect frequency context switch</b>	The frequency context parameter has been changed either by the user or the system. The frequency menu will now contain the frequencies for the new context. No action required
<b>Gate required for valid results</b>	
<b>High-pass and Low-pass filters set to OFF</b>	Turning on any band pass filter will turn off high-pass and low-pass filters
<b>High-pass filter set to OFF</b>	Turning on any band pass filter will turn off high-pass filters
<b>IF Fixed freq should be greater than LO Stop freq</b>	The setup frequencies break the rules for an upconverter measurement. The measurement will still run, but check setup frequencies are correct before continuing. The IF fixed freq should be greater than the LO Stop freq for a USB upconverter swept LO setup. Use the graph icon on the DUT setup form to clarify the setup required
<b>IF Fixed freq should be greater than RF Stop freq</b>	The setup frequencies break the rules for an upconverter measurement. The measurement will still run, but check setup frequencies are correct before continuing. The IF fixed freq should be greater than the RF Stop freq for an upconverter swept LO setup. Use the graph icon on the DUT setup form to clarify the setup required
<b>IF Start freq should be greater than LO Fixed freq</b>	The setup frequencies break the rules for an upconverter measurement. The measurement will still run, but check setup frequencies are correct before continuing. The IF start freq should be greater than the LO fixed freq for an USB upconverter fixed LO setup. Use the graph icon on the DUT setup form to clarify the setup required
<b>IF Start freq should be greater than RF Start freq</b>	The setup frequencies break the rules for an upconverter measurement. The measurement will still run, but check setup frequencies are correct before continuing. The IF start freq should be greater than the RF Start freq for an upconverter fixed LO setup. Use the graph icon on the DUT setup form to clarify the setup required
<b>Input is internal</b>	The instrument's input is set to internal (the internal amplitude reference signal). So any signals connected to the front/rear panel inputs cannot be measured
<b>LO Fixed freq should be greater than IF Stop freq</b>	The setup frequencies break the rules for an upconverter measurement. The measurement will still run, but check setup frequencies are correct before continuing. The LO fixed freq should be greater than the IF Stop freq for an LSB upconverter fixed LO setup. Use the graph icon on the DUT setup form to clarify the setup required



Message	Description/Correction Information
LO Fixed freq should be greater than RF Stop freq	The setup frequencies break the rules for a downconverter measurement. The measurement will still run, but check setup frequencies are correct before continuing. The LO fixed freq should be greater than the RF Stop freq's for an LSB or DSB (for DSB measurements the setup uses LSB values) downconverter fixed LO setup. Use the graph icon on the DUT setup form to clarify the setup required
LO Start freq should be greater than IF Fixed freq	The setup frequencies break the rules for an upconverter measurement. The measurement will still run, but check setup frequencies are correct before continuing. The LO Start freq should be greater than the IF fixed freq for an LSB upconverter swept LO setup. Use the graph icon on the DUT setup form to clarify the setup required
LO Start freq should be greater than RF Start freq	The setup frequencies break the rules for a downconverter measurement. The measurement will still run, but check setup frequencies are correct before continuing. The LO start freq should be greater than the RF Start freq's for an LSB downconverter swept LO setup. Use the graph icon on the DUT setup form to clarify the setup required
LO Stop freq should be greater than RF Stop freq	The setup frequencies break the rules for a downconverter measurement. The measurement will still run, but check setup frequencies are correct before continuing. The LO Stop freq should be greater than the RF Stop freq's for a DSB (for DSB measurements the setup uses LSB values) downconverter swept LO setup. Use the graph icon on the DUT setup form to clarify the setup required
Low-pass filter set to OFF	Turning on any band pass filter will turn off low-pass filters
No spurs have been found	You started a measurement in examine meas type in single or continual sweep mode, or full meas type in single sweep mode, but no spurs were found
Preparing Calculation...	
Preselector is centered	The preselector has been successfully centered
Preselector not used in this frequency range.	You cannot center or adjust the preselector because it is not used at all at the current marker frequency or between the current start and stop frequencies
Probe connected, cal data is being reapplied; <port>; <probe>	A probe has been connected, calibration data is being reapplied
Probe connected, no probe cal; using cable cal data; <port>; <probe>	A probe has been connected and no probe calibration data is available. The latest cable calibration data will be used
Probe disconnected, reverting to cable calibration data; <port>	A probe has been disconnected, calibration data reverting to the last cable calibration data
Reading SNS data...	The Keysight Smart Noise Source has been connected and the application is reading the device EEPROM data. Please wait until complete before continuing
Recalled File <filename>	A file recall (open/load) was successfully completed

<b>Message</b>	<b>Description/Correction Information</b>
Refer to online help for assistance with DSB measurements	The Double Side Band measurement requires careful setup to obtain valid results. Please refer to the manuals for help with this setup
Requested timeslot number is not present.	The selected timeslot is not on. (Timeslot is referenced to the trigger point)
RF Start freq should be greater than IF Fixed freq	The setup frequencies break the rules for a downconverter measurement. The measurement will still run, but check setup frequencies are correct before continuing. The RF Start freq should be greater than the IF Fixed freq for a DSB (for DSB measurements the setup uses LSB values) downconverter swept LO setup. Use the graph icon on the DUT setup form to clarify the setup required
RF Start freq should be greater than IF start freq	The setup frequencies break the rules for a downconverter measurement. The measurement will still run, but check setup frequencies are correct before continuing. The RF start freq should be greater than the IF Start freq's for an LSB downconverter fixed LO setup. Use the graph icon on the DUT setup form to clarify the setup required
RF Start freq should be greater than LO fixed freq	The setup frequencies break the rules for a downconverter measurement. The measurement will still run, but check setup frequencies are correct before continuing. The RF start freq should be greater than the LO fixed freq's for an USB downconverter fixed LO setup. Use the graph icon on the DUT setup form to clarify the setup required
RF Start freq should be greater than LO Start freq	The setup frequencies break the rules for a downconverter measurement. The measurement will still run, but check setup frequencies are correct before continuing. The RF start freq should be greater than the LO Start freq's for an USB downconverter swept LO setup. Use the graph icon on the DUT setup form to clarify the setup required
RF Stop freq should be greater than IF Stop freq	The setup frequencies break the rules for a downconverter measurement. The measurement will still run, but check setup frequencies are correct before continuing. The RF Stop freq should be greater than the IF Stop freq's for an USB or DSB (for DSB measurements the setup uses LSB values) downconverter fixed LO setup. Use the graph icon on the DUT setup form to clarify the setup required
Scale/Div only applies in Log Y Scale	Setting the Scale/Division only makes sense when you are using a logarithmic Y scale
Signal Track is turned off when Zero Span is selected	Signal Track is not available when you have selected Zero Span. So if Zero Span is entered while in Signal Track is On, Signal Track is turned off
Signals deleted	The signals in the signal list were successfully deleted
Sweep Points/Span is < minimum. Results may be inaccurate.	The sweep point to span ratio is below the minimum required to ensure the bucket ratio is large enough to test DVB-T masks
Sweep Setup is not available in Zero Span	Zero span is a display at a single frequency, so there is no "sweeping" to set up

Instrument Messages  
Advisory Messages

<b>Message</b>	<b>Description/Correction Information</b>
Sync is RF Ampl (not Training Sequence). Bits are not accurate.	
Trace file saved.	The trace saving operation was successful
Use Gate View Sweep Time in the Gate menu.	When in Gate View you use Gate View Sweep Time, rather than Sweep Time, to control the Gate View window
User Cal valid. Apply Cal from Meas Setup menu	The measurement setup has changed such that the current cal data can be applied to the results. To apply the cal, press Meas Setup/Cal Setup/Apply Calibration. A new cal can be performed if required

## Event Messages

Event messages are displayed in the MSG area in the bottom left of the instrument display. Event messages and message numbers are defined by the SCPI standard.

In the X-Series, sub-messages are often attached to add additional information, to help you better understand the event being reported. For example, error -221 is defined as `Settings Conflict`, but in the X-Series you will often see a longer message appended to error -221, such as `Settings Conflict; Function not available in Zero Span`. This helps you understand the exact cause of the Settings Conflict error.

## -800, Operation Complete Event

<b>Err#</b>	<b>Message</b>	<b>Verbose/Correction Information</b>
-800	<b>Operation complete</b>	The instrument has completed all selected pending operations in accordance with the IEEE 488.2, 12.5.2 synchronization protocol

## -700, Request Control Event

<b>Err#</b>	<b>Message</b>	<b>Verbose/Correction Information</b>
-700	<b>Request control</b>	The instrument requested to become the active IEEE 4881 controller-in-charge

## -600, User Request Event

<b>Err#</b>	<b>Message</b>	<b>Verbose/Correction Information</b>
-600	<b>User request</b>	The instrument has detected the activation of a user request local control

## -500, Power on Event

<b>Err#</b>	<b>Message</b>	<b>Verbose/Correction Information</b>
-500	<b>Power on</b>	The instrument has detected an off to on transition in its power supply

## -400 to -499, Query Errors

<b>Err#</b>	<b>Message</b>	<b>Verbose/Correction Information</b>
-400	<b>Query Error</b>	There was a problem with a query command. The exact problem cannot be specifically identified
-410	<b>Query INTERRUPTED</b>	Some condition caused an INTERRUPTED query to occur. For example, a query was followed by DAB or GET before a response was completely sent
-420	<b>Query UNTERMINATED</b>	Some condition caused an UNTERMINATED query to occur. For example, the device was addressed to talk and an incomplete program message was received
-430	<b>Query DEADLOCKED</b>	Some condition caused a DEADLOCKED query to occur. For example, both the input buffer and the output buffer are full and the analyzer cannot continue. The analyzer automatically discards output to correct the deadlock
-440	<b>Query UNTERMINATED after indefinite response</b>	A query was received in the same program message after a query requesting an indefinite response was executed

## -300 to -399, Device-Specific Errors

Err#	Message	Verbose/Correction Information
-300	<b>Device-specific error</b>	An instrument error occurred and the exact problem cannot be specifically identified. Report this error to the nearest Keysight Technologies sales or service office
-310	<b>System error;</b>	An internal system-type error has occurred. The exact problem cannot be specifically identified. Report this error to the nearest Keysight Technologies sales or service office
-310	<b>System error; A license will soon expire; &lt;feature code&gt; will expire in &lt;time&gt;</b>	The indicated feature/software will expire in the specified time. Contact Keysight Technologies to purchase continued use of this functionality
-310	<b>System Error; enable GPIB controller mode</b>	Press <b>System, I/O Config, GPIB</b> and set GPIB Controller to Enabled so that the analyzer can control the source over GPIB
-310	<b>System error; Error transmitting a LAN event to the network.</b>	Communication with the network driver failed
-310	<b>System error; Failed to initialize the PTP clock to current time.</b>	Failure communicating with the DMC libraries' PTP controller
-310	<b>System error; Failed to instantiate the PTP ordinary clock.</b>	Failure in the starting up the DMC libraries' PTP controller
-310	<b>System error; feature &lt;feature code&gt; not licensed</b>	The specified feature, for example "N9073A-TR2", is not licensed. The license may have expired. You cannot use it until you obtain a license
-310	<b>System error; Feature expired; &lt;feature code&gt;</b>	The specified feature has expired. The license is no longer valid
-310	<b>System error; License installation failed; &lt;feature code&gt;</b>	The license installation of the specified feature, for example "N9073A-TR2", has failed. You should refer to the event log in the control panel for more details
-310	<b>System error; License removal failed; &lt;feature code&gt;</b>	The license removal of the specified feature, for example "N9073A-TR2" has failed. You should refer to the event log in the control panel for more details
-310	<b>System error; No license; &lt;feature code&gt; will terminate in &lt;time&gt;</b>	The specified feature will stop working in the specified time due to the license expiration You will be prompted to save results and exit

Instrument Messages  
Event Messages

<b>Err#</b>	<b>Message</b>	<b>Verbose/Correction Information</b>
-310	System Error; No supported source found	Signal source at given IP address is not responding / IP does not belong to a source. Check IP address and network connection
-310	System Error; source connection lost, check interface connection	Signal source at given IP address is not responding / IP does not belong to a source. Check IP address and network connection
-310	System error; The configured PTP hardware driver could not be instantiated.	The PTP driver failed on initialization
-310	System error; The PTP hardware driver reported a configuration error.	Failure in the execution of the PTP driver. The most likely cause of this error is a mismatch between versions of the PTP driver and the LXI middleware
-310	System error; The PTP ordinary clock reported a configuration error.	Failure in execution of the DMC libraries' PTP controller
-310	System error; The Trigger alarm delayed LAN event was not scheduled due to an existing pending event.	Delayed LAN events cannot occur too close together (within 20 ms)
-310	System error; The Trigger alarm delayed LAN event was not scheduled due to a conflict with an existing scheduled alarm.	Delayed LAN events cannot occur too close to a scheduled Alarm (within 20 ms)
-310	System error; The Trigger alarm was not scheduled due to a conflict with an existing scheduled alarm.	Alarms cannot be scheduled to happen too close together (within 20 ms)
-311	Memory error	There is a physical problem with the instrument memory, such as a parity error
-312	PUD memory lost	Protected user data saved by the *PUD command has been lost
-313	Calibration memory lost	The nonvolatile calibration data used by the *CAL? command has been lost

Instrument Messages  
Event Messages

Err#	Message	Verbose/Correction Information
-314	Save/recall memory lost	The nonvolatile data saved by the *SAV? command has been lost
-315	Configuration memory lost	The nonvolatile configuration data saved by the instrument has been lost
-320	Storage fault;	A problem was found while using data storage. The error is not an indication of physical damage or failure of any mass storage element
-321	Out of memory	An internal operation needed more memory than was available. Report this error to the nearest Keysight Technologies sales or service office
-330	Self-test failed	A self-test failure occurred. Report this error to the nearest Keysight Technologies sales or service office
-340	Calibration failed	The instrument requires an Align All Now. Restore the alignment by pressing <b>System, Alignments, Align All Now</b>
-340	Calibration failed; <failure msg> <port>	The calibration for one of the I-Q ports did not succeed. The information in the "failure msg" field can be used to troubleshoot this problem. Contact Keysight technical support
-350	Queue overflow	An error occurred that did not get put in the error queue because the queue was full
-360	Communication error	There was a problem with instrument remote communications. The exact problem cannot be specifically identified
-360	Communication error; SNS data read failure. Disconnect then reconnect SNS	The Keysight Smart Noise Source connected to the instrument has failed to be read by the application. Please disconnect and reconnect the SNS. If this continues to fail, then the SNS may have had its EEPROM corrupted or another hardware fault exists. Check SNS on another instrument, NFA and ESA are also SNS compatible instruments. Check that the device is not an Keysight power sensor which uses the same cable interface
-360	Communication error; SNS is not connected	The Keysight Smart Noise Source connected to the instrument has failed to be read by the application. Please disconnect and reconnect the SNS. If this continues to fail, then the SNS may have had its EEPROM corrupted or another hardware fault exists. Check SNS on another instrument, NFA and ESA are also SNS compatible instruments. Check that the device is not an Keysight power sensor which uses the same cable interface
-361	Parity error in program message	A parity bit was not correct when the data was received. For example, on a parallel port
-362	Framing error in program message	A stop bit was not detected when data was received. For example, on a remote bus port
-363	Input buffer overrun	A software or hardware input buffer on a port overflowed with data because of improper or nonexistent pacing
-365	Time out error	There was a time-out problem in the instrument. The exact problem cannot be specifically identified



## -221 Settings Conflict Errors

This is one of the errors in the standard SCPI error range -200 to -299. For all other errors in this range, see “-200 to -299, Execution Errors” on page 101.

Err#	Message	Verbose/Correction Information
-221	De-emphasis only available in FM	The de-emphasis function is only available if FM demod is selected
-221	Function not available in Zero Span	The function you are trying to access is not available in zero span
-221	Setting conflict; <trigger source> trigger is not available while input is <input port>	The trigger source (Video, RF Burst, I/Q Mag, etc.) is not available with the current input port (RF, IQ, etc.)
-221	Setting conflict; Differential setting determined by probe type	A probe is connected that has a built in Differential setting. The setting cannot be changed manually
-221	Setting conflict; Input Z unavailable when probe sensed	A probe is connected and the Input Z is set based on the probe type. It cannot be changed manually
-221	Settings conflict;	A legal command was received but it could not be executed due to the current device state
-221	Settings conflict; *.CSV file format is not available in this measurement.	You cannot load or save base instrument traces, as this is not supported by the Log Plot measurement
-221	Settings conflict; <Q Param> cannot be changed when Q same as I	When the <b>Q Same as I</b> parameter is set to Yes, the I parameter value is copied to <Q Param> and the <Q Param> value cannot be changed. Set <b>Q Same as I</b> to No to enable explicit control of the <Q Param> value
-221	Settings conflict; A Valid User Cal is required. Optimize aborted	Optimize Preselector can only be performed if a valid user cal exists and is applied to current results. Perform a user cal first or apply existing cal
-221	Settings conflict; Auto Tune not available in Tracking Source mode	The Auto Tune feature cannot be used when you are using a Tracking Source
-221	Settings conflict; BTS gain is not available in this Mode	Base Transceiver Station gain correction is not available in some Modes, or in some measurements (for example, the SA measurement)

Instrument Messages  
Event Messages

<b>Err#</b>	<b>Message</b>	<b>Verbose/Correction Information</b>
-221	<b>Settings conflict; Cal only available when Source Mode is Tracking</b>	You must be in Tracking Source mode to use the Cal functions under Normalize. Press Source, Source Mode and set it to Tracking
-221	<b>Settings conflict; Calibration cannot be performed without valid ENR data</b>	The cal ENR table has no values in it, and hence the cal cannot be performed. Correct by either populating the cal ENR table, set ENR mode to Spot, or set the 'Use Meas Table Data for Cal' to 'On'
-221	<b>Settings conflict; Cancellation is not available while measuring DANL floor.</b>	Phase Noise cancellation does not make sense when measuring the DANL Floor, so for this reason it has been disabled
-221	<b>Settings conflict; Cancellation Ref trace has no data.</b>	When performing phase noise cancellation, you need to supply a reference trace that will be used to cancel out the background noise of the analyzer. The reference trace must be in Reference (View) mode, and selected by the Ref Trace parameter under the Cancellation menu
-221	<b>Settings Conflict; Cancellation trace has different X-Scale</b>	Reference trace for the cancellation has a different range of X-axis against the target trace
-221	<b>Settings conflict; Cannot optimize while user cal in progress</b>	Optimize Preselector cannot be performed while a user cal is in progress. The user cal performs an optimize preselector prior to taking the noise source on/off level results for the cal data
-221	<b>Settings conflict; Can't Auto-Couple Res BW in Zero Span</b>	The resolution bandwidth cannot be set to auto while you are in zero span (time domain)
-221	<b>Settings conflict; Carrier freq not allowed with BMT. (Bottom/Middle/Top only)</b>	The transmit band spur measurement only allows bottom (B), middle (M), and top (T) channel frequencies for each supported frequency band. The carrier frequency must be set to the bottom, middle or top frequency of the current frequency band
-221	<b>Settings Conflict; Code channel duplication</b>	This error is reported when the given code channel overlaps other code channel
-221	<b>Settings conflict; Continuous Peak is not available with Fixed marker</b>	The continuous peak feature cannot be used with a marker that is fixed. By definition that marker value cannot change
-221	<b>Settings conflict; Continuous Peak is not available with Signal Track on</b>	The continuous peak feature cannot be used while you are also using the signal tracking function

Instrument Messages  
Event Messages

Err#	Message	Verbose/Correction Information
-221	Settings conflict; Destination trace for Trace Math cannot be a trace operand	The resulting trace data (from doing a trace math function) cannot be put into the any of the traces that are being used by the math operation
-221	Settings conflict; Downconv only available when DUT is Amplifier	SCPI only message. The System Downconverter can only be set to 'On' when the DUT type is amplifier. Change DUT type to Amplifier if the System Downconverter is required
-221	Settings conflict; EDGE EVM only supports EDGE TCH burst type.	
-221	Settings conflict; Electronic attenuator is disabled	You are using the mechanical attenuator, and have not enabled the electronic attenuator. You cannot set the value of the electronic attenuator because it automatically sets/changes when enabled
-221	Settings conflict; Electronic attenuator is not available above 3.6 GHz	The maximum frequency of the electronic attenuator is 3.6 GHz. This is because of switching capacitance
-221	Settings conflict; Electronic attenuator unavailable in current state	
-221	Settings conflict; Electronic attenuator unavailable with Preamp on	The internal preamp is on. Electronic attenuator cannot be used while you are using the internal preamp
-221	Settings conflict; EMI Detectors are not available in FFT sweep	QPD, EMI Average, EMI Peak, and MIL Peak are not allowed when in the manually selected FFT sweep mode
-221	Settings conflict; External Mixer not available	A command has been sent to reference the External Mixer in a model that does not contain it
-221	Settings Conflict; FAST method can only be used while Radio Std is W-CDMA	
-221	Settings conflict; Feature not available in this View	Some functionality is available in one View, but not in another. (See the Views under the <b>View/Display</b> key.) This error occurs if you send a SCPI command or push a grayed-out key that is not available in the current selected View

Instrument Messages  
Event Messages

Err#	Message	Verbose/Correction Information
-221	Settings conflict; Feature not supported for selected source	You have selected a feature that the selected source does not support
-221	Settings conflict; Feature not supported for this Input.	Some functionality is not available when certain Inputs are selected. For example, Trigger Holdoff is not available for the BBIQ input
-221	Settings conflict; Feature not supported for this measurement.	Some functionality is available in one measurement, but not in another. (See the measurements under the <b>Meas</b> key.) This error occurs if you send a SCPI command or push a grayed-out key that is not available in the current selected measurement
-221	Settings conflict; Feature not supported for this model number	This functionality is not a part of the instrument you are using, but may be found in other models in the X-Series
-221	Settings conflict; FFT IF Gain High not available when Swept IF Gain = Manual Low	When Swept IF Gain is manually set to Low, you cannot set the FFT IF Gain to High because that would make the Reference Level couplings wrong in FFT mode
-221	Settings conflict; FFT method is unavailable for level gating	If you are using level gating, you cannot select the FFT Gate Method
-221	Settings conflict; FFT sweep type is not available while in Gated LO	The gated LO function turns the LO on and off as it sweeps, so the FFT sweep type is not available if you have selected gated LO
-221	Settings conflict; FFT sweep type is not available while in Gated Video	The FFT sweep type is not available if you have selected the gated video function
-221	Settings conflict; FFT Sweeps unavailable in Tracking Source mode	Since FFTs do not sweep, you cannot use a Tracking Source while doing FFTs
-221	Settings conflict; Fixed marker adjust not available while Marker Function is on	If a Marker Function is on for a Fixed marker, the marker's reported value is derived from the function. Therefore, you cannot directly set the X or Y value of a Fixed marker that has a marker function turned on
-221	Settings conflict; Fixed Marker Y value is not adjustable with Normalize On	If Normalize is on the Amplitude scale is in dB units, so adjusting the Y value of a Fixed marker is not possible

Instrument Messages  
Event Messages

<b>Err#</b>	<b>Message</b>	<b>Verbose/Correction Information</b>
-221	<b>Settings conflict; Freq &gt; 3.6 GHz unavailable while electronic attenuator enabled</b>	The electronic attenuator does not function above 3.6 GHz, so if you have that attenuator enabled, you cannot change the center frequency so that frequencies above 3.6 GHz are displayed/measured
-221	<b>Settings conflict; Function not available in External Mixing</b>	The frequency offset feature cannot be used when you have selected a log scale for the frequency axis
-221	<b>Settings conflict; Function not available in Tracking Source mode</b>	The feature cannot be used when you are using a Tracking Source
-221	<b>Settings conflict; Function only available in Tracking Source mode</b>	The feature cannot be used unless you are using a Tracking Source
-221	<b>Settings conflict; Function unavailable with MW Presel off</b>	You cannot center or adjust the preselector because the Microwave Preselector is currently off
-221	<b>Settings conflict; Gate control is Edge for Gated FFT</b>	You cannot use level triggering to control the gate if you are using the FFT gating method
-221	<b>Settings conflict; Gate control must be Edge for this Gate Source</b>	You cannot use level triggering to control the gate when you are using the currently selected gate source
-221	<b>Settings conflict; Gate is not available when Marker Count on</b>	The gate function cannot be used while you have marker count turned on
-221	<b>Settings conflict; Gate Length is not settable in FFT sweeps</b>	The sweep time for FFT sweeps is set by the calculations, so sweep time settings cannot be adjusted
-221	<b>Settings conflict; Gate Length is not settable in FFT sweeps</b>	The sweep time for FFT sweeps is set by the calculations, so sweep time settings cannot be adjusted
-221	<b>Settings conflict; Gate Method is not compatible with current Sweep Type setting</b>	If the Gate is On and you have the FFT Sweep Type manually selected, then the Gate Method cannot be selected

Instrument Messages  
Event Messages

<b>Err#</b>	<b>Message</b>	<b>Verbose/Correction Information</b>
-221	<b>Settings conflict; Gate not available with external Tracking Source</b>	The Gate functions are unavailable when Source Mode is Tracking with an external source. This is because the Gate circuitry is used to sync the external source
-221	<b>Settings conflict; Gate not available with Tracking Generator</b>	If the Source Type is Tracking Generator, the Gate circuitry is used for TG sync and is not available for gating
-221	<b>Settings conflict; Gated FFT is not available while Sweep Type is set to Swept</b>	The gated FFT function is not available if you have selected the swept type of sweep. You must be in the FFT sweep type
-221	<b>Settings conflict; Gated LO is not available while Sweep Type is set to FFT</b>	The FFT sweep type moves the LO frequency in steps. So the gated LO function is not available if you have selected FFT sweep
-221	<b>Settings conflict; Gated Video is not available while Sweep Type is set to FFT</b>	The gated video function is not available if you have selected the FFT sweep type
-221	<b>Settings conflict; Incorrect RBW for demod. Change RBW</b>	
-221	<b>Settings conflict; Ind I/Q is not available for this measurement</b>	The Independent I and Q setting is not available for the current measurement. Only some measurements (initially, only VXA) support this setting
-221	<b>Settings conflict; Invalid trace number</b>	The subopcode used to specify the trace number is invalid for this measurement or query
-221	<b>Settings conflict; Knob is not available to modify this function</b>	You should select a specific value for this function. Scrolling through values with the knob is not allowed
-221	<b>Settings conflict; LO Phase Noise Adj not available</b>	For instruments without the Dual-Loop LO, this feature is not available
-221	<b>Settings conflict; Marker 1 Trace Update=off turns off Signal Track</b>	Signal Track not available unless the trace containing Marker 1 is updating
-221	<b>Settings conflict; Marker cannot be relative to itself</b>	A marker must be set relative to another marker, not to itself

Instrument Messages  
Event Messages

Err#	Message	Verbose/Correction Information
-221	Settings conflict; Marker Count is not available when Gate on	The marker count function cannot be used while you have gating turned on
-221	Settings conflict; Marker Function is not available for a Fixed marker	If a Marker is a Fixed type marker, the marker's value does not change from when it first became fixed. You cannot turn on or change a Marker Function because there is no ongoing measurement data to use for the marker function calculation
-221	Settings conflict; Marker type must be delta	Mkr?->Span and Mkr?->CF require that the selected marker be a delta marker
-221	Settings conflict; Marker-> function is not available in zero span	Most of the <b>Marker To</b> functions are not available if you are in zero span (span = 0 Hz, or time domain), so you cannot send the commands for these functions
-221	Settings conflict; Mask unavailable for current Span. Increase to display mask.	The current span setting is either narrower than the mask width or so wide that there are too few display points to allow the mask to be drawn. Increase or decrease the span to display the mask
-221	Settings conflict; Meas Type was changed to Examine for Exp Avg Mode.	Average Mode has been changed to Exponential. Full Meas Type is not available for Exponential Average Mode, therefore Meas Type has been changed to Examine
-221	Settings conflict; Meas Type was changed to Full for Repeat Avg Mode	Average Mode has been changed to Repeat. Examine Meas Type is not available for Repeat Average Mode therefore Meas Type has been changed to Full
-221	Settings Conflict; MinPts/RBW limit not met	
-221	Settings conflict; Mkr -> CF is not available when the x-axis is time domain	The marker to center frequency functionality does not work when the X-axis is in the time domain
-221	Settings conflict; Mod Scheme AutoDet unavailable when Burst Sync=RF Amptd	The modulation scheme auto detection is unavailable when the burst sync is set to RF Amptd (GSM/EDGE)
-221	Settings conflict; MS gain is not available in this Mode	Mobile Station gain correction is not available in some Modes, or in some measurements (for example, the SA measurement)

Instrument Messages  
Event Messages

<b>Err#</b>	<b>Message</b>	<b>Verbose/Correction Information</b>
-221	<b>Settings conflict; Must apply Amplitude Correction to make this unit available</b>	These special units only apply when you are doing antenna measurements, so you must have a correction that includes Antenna Units enabled
-221	<b>Settings conflict; No meas frequencies are above 3.6 GHz</b>	Optimize Preselector can only be performed on frequencies in high band, that is, above 3.6 GHz. The current setup does not have input frequencies (IF) in this range so an Optimize Preselector cannot be performed
-221	<b>Settings conflict; no source selected</b>	You must select a source using Select Source before you can do this
-221	<b>Settings conflict; Normalize is not available when Scale Type = Lin</b>	Normalize does not support Linear amplitude scale, since the results are always presented as a dB ratio
-221	<b>Settings conflict; Normalize is not available while Demod View is on</b>	The normalization (correction) function cannot be used if you are using the Demod View
-221	<b>Settings conflict; Normalize is not available while Trace Math is on</b>	The Normalize function works by doing trace manipulation, so if trace math is on you cannot turn on normalization
-221	<b>Settings conflict; Only active Antenna Unit available; no other Y axis units</b>	When a correction with antenna units is turned on, the only Y-axis units you can have are those that match the Antenna Unit. Turn off the Correction or the Antenna Unit under Input/Output, Corrections
-221	<b>Settings conflict; Option not available</b>	You have attempted to perform an action for which a required option is not installed
-221	<b>Settings conflict; Param only available when DUT is a freq converter</b>	SCPI only message. The sideband and freq context parameters are only available when a freq conversion setup is in use. Change setup to contain a freq conversion to use these parameters
-221	<b>Settings conflict; Param only available when External LO Mode is Swept</b>	SCPI only message. This parameter is only available when the LO mode is set to Swept. Change the LO Mode to Swept
-221	<b>Settings conflict; Param only available when External LO Mode is Fixed</b>	SCPI only message. This parameter is only available when the LO mode is set to Fixed. Change the Freq Mode to Fixed
-221	<b>Settings conflict; Param only available when Frequency Mode is Fixed</b>	SCPI only message. This parameter is only available when the Freq mode is set to Fixed. Change the Freq Mode to Fixed



Instrument Messages  
Event Messages

<b>Err#</b>	<b>Message</b>	<b>Verbose/Correction Information</b>
-221	Settings conflict; Param only available when Frequency Mode is Swept	SCPI only message. This parameter is only available when the Freq mode is set to Swept. Change the Freq Mode to Swept
-221	Settings conflict; Param only available when valid cal data exists	SCPI only message. The 'Apply Calibration' parameter is only available when the stored cal data matches the current setup. Perform a fresh 'Calibrate Now' or change setup such that current cal data is valid
-221	Settings conflict; Preamp gain is not available in this Mode	Preamp gain correction is not available in some Modes or Measurements
-221	Settings conflict; Preamp unavailable with electronic attenuator on	The electronic attenuator is on. Internal preamp cannot be used while you are using the electronic attenuator
-221	Settings conflict; Reference marker must be in same window	A delta marker and its reference must be in the same window. This error occurs when you try to turn on a delta marker for which the reference is in a different window
-221	Settings conflict; Relative Trigger needs hardware support for this meas	To do Relative Triggering in this measurement requires optional hardware that is not present in this analyzer
-221	Settings conflict; Scale Type = Lin is not available when Normalize is on	Only the Log amplitude scale is available in Normalize, since the results are always presented as a dB ratio
-221	Settings conflict; Settings conflict; Pre-trigger is insufficient for demod. Decrease Trig Delay.	
-221	Settings conflict; Signal Track is not available with Continuous Peak	The signal tracking feature cannot be used while you are also using the continuous peak function
-221	Settings conflict; Signal Track is only available in Swept SA measurement	The signal track functionality can be used when making a swept SA measurement. It is not available in the SA measurement when you are using FFT sweeps

Instrument Messages  
Event Messages

Err#	Message	Verbose/Correction Information
-221	Settings conflict; Signal Track is turned off when Zero Span is selected	Signal Track is not available when you have selected Zero Span. So if Zero Span is entered while in Signal Track is On, Signal Track is turned off
-221	Settings Conflict; Span limited to XXX	
-221	Settings conflict; Span Zoom is not available in Zero Span	Span Zoom does not work with a time domain X-axis. You must select a span greater than 0 Hz
-221	Settings conflict; Step keys are not available to modify this function	You should select a specific value for this function. Using the <b>Up/Down</b> step keys to scroll through values is not allowed
-221	Settings conflict; Sweep Setup only available in swept measurements	The current measurement uses FFT mode, so does not use the Sweep Setup menu
-221	Settings conflict; Sweep Time cannot be auto-coupled in FFT sweeps	The sweep time for FFT sweeps is set by the calculations. So sweep time settings cannot be adjusted
-221	Settings conflict; Sweep Time cannot be auto-coupled while in Zero Span	You cannot send the remote command to set the sweep time to auto while you are in zero span
-221	Settings conflict; Sweep Time cannot be set while in FFT sweeps	The sweep time for FFT sweeps is set by the calculations. It cannot be manually controlled
-221	Settings conflict; Swept IF Gain High not available when FFT IF Gain = Manual Low	When FFT IF Gain is manually set to Low, you cannot set the Swept IF Gain to High because that would make the Reference Level couplings wrong in swept mode
-221	Settings conflict; Swept LO not available when freq mode is Fixed	SCPI only message. The LO Mode cannot be set to Swept when the freq mode is set to fixed. Change the freq mode away from fixed, or perform the measurement at several fixed frequencies
-221	Settings conflict; Swept Type=Swept is not available while in Gated FFT	If you have selected gated FFT then you are using the FFT sweep type and you cannot select the swept type of sweeping

Instrument Messages  
Event Messages

Err#	Message	Verbose/Correction Information
-221	Settings conflict; System Display Settings, Annotation is Off	This is an override that turns off many of the annotations. This is available as a security feature
-221	Settings conflict; T hot must be greater than T cold	The Tcold value set under <b>Meas Setup, ENR, Tcold</b> needs to be lower than the Thot value currently being set. Tcold is often taken as the ambient temperature of the noise source. If using an SNS the Tcold value may be read automatically before every sweep
-221	Settings Conflict; The parameter cannot be changed in FAST mode	
-221	Settings conflict; Trace Math is not available while Normalize is on	The Normalize function works by doing trace manipulation, so trace math is not available while normalization is running
-221	Settings conflict; Tracking Source unavailable in FFT Sweeps	Since FFTs do not sweep, you cannot use a Tracking Source while doing FFTs
-221	Settings conflict; Trigger input in use for source synchronization	If Point Trigger is being used with an external trigger input to synchronize an external source to the analyzer, that trigger input is unavailable for triggering
-221	Settings conflict; Trigger is not available with span > 0 Hz.	
-221	Settings conflict; Tx Band Spur meas does not support this frequency band.	The transmit band spur measurement does not support all of the commercially available frequency bands. You need to change your selection under <b>Mode Setup, Radio, Band</b> to one of the supported bands
-221	Settings conflict; Tx Band Spur measurement is not defined for mobiles.	Only base station testing is available
-221	Settings conflict; Administrat or privileges required	You must be logged in with administrator privileges to do this. Log out and log back in as the Administrator, then restart the SA application

Instrument Messages  
Event Messages

<b>Err#</b>	<b>Message</b>	<b>Verbose/Correction Information</b>
-221	Settings conflict;Auto Scan Time/Meas Time do not apply in Stepped Scan Type.	The Auto Scan Time/Meas Time are not available when Scan Type =Stepped Scan
-221	Settings conflict;Auto Scan Time/Meas Time do not apply in Stepped Scan Type.	The Auto Scan Time/Meas Time are not available when Scan Type =Stepped Scan
-221	Settings conflict;ClearList & Start not available when ScanSeq = (Re)measure	Cannot perform Clear List & Start during (Re)measure, because we require the frequency information of the peaks in signal list to perform (Re)measure
-221	Settings conflict;EMI Detectors and Average detector can't be used together	You cannot turn on any EMI Detector and Average detector together. They are always mutually exclusive
-221	Settings conflict;Freq > 1 GHz is not available while RF Input 2 enabled	Frequency is limited to 1GHz while RF Input 2 is enabled
-221	Settings conflict;Function not available while measurement is running	Settings change is not allowed while measurement is running. You must stop the current measurement if you wish to change the settings
-221	Settings conflict;function unavailable with this EMC Standard	
-221	Settings conflict;Log Percent Auto Step Rule does not apply in Swept Scan Type.	The Log Percent rule is not available when Scan Type=Swept Scan because we are always doing linear sweep
-221	Settings conflict;QPD + EMI Average + RMS Average is not allowed	You cannot turn on all 3 EMI detectors together. You must turn off one of the EMI Detectors before you turn this on

Err#	Message	Verbose/Correction Information
-221	Settings conflict;Range <0> is turned off as total range points > 40001	Max of Total range points is 400000. Reduce Scan Points or increase Step Size in order to turn on that range
-221	Settings conflict;RF Input 2 is not available above 1GHz	If the frequency range is set above 1GHz, you cannot change to RF Input 2
-221	Settings conflict;Scan Time & Points do not apply in current Step/Time Control.	The Scan Time & Points are not available when Step/Time Control is set to Step & Dwell
-221	Settings conflict;Step Size & Meas Time do not apply in current Step/Time Control.	The Step Size & Meas Time are not available when Step/Time Control is set to Scan Time&Pts

## -200 to -299, Execution Errors

This section lists all messages in the range except -221 error messages. For details of -221 messages, see [“-221 Settings Conflict Errors” on page 89](#).

Note that Execution Errors are divided into subclasses, as follows:

- 21x Trigger errors
- 22x Parameter error
- 23x Data corrupt or stale (invalid data)
- 24x Hardware error
- 25x Mass storage error
- 26x Expression data error
- 27x Macro error
- 28x Program error (a downloaded program-related execution error)
- 29x Memory use error

Err#	Message	Verbose/Correction Information
-200	All ranges are off. Turn on at least a range	There are no range turn on in scan table. You need to turn on at least a range to initiate a scan
-200	At Full Zoom	Marker Zoom is not available as it has reached full zoom

Instrument Messages  
Event Messages

<b>Err#</b>	<b>Message</b>	<b>Verbose/Correction Information</b>
-200	<b>At Full Zoom</b>	Marker Zoom is not available as it has reached full zoom
-200	<b>Execution Error</b>	A program execution error has occurred. The exact problem cannot be specifically identified
-200	<b>Execution error; Carrier frequency outside device's transmit band</b>	The entered channel/carrier frequency is not within the range of your current mode setup selection of standard and device
-200	<b>Execution error; Invalid GSM burst timing</b>	A GSM-like burst was acquired, but its timing is not valid. Ensure the correct Burst Type has been selected
-200	<b>Execution error; Invalid IP address</b>	The IP address supplied is either not valid or does not belong to a compatible Signal Generator. Please check the IP address and instrument connection and try again
-200	<b>Execution error; Invalid Marker Trace.</b>	Cannot place markers on the reference trace, because the reference trace is currently turned off or has no data
-200	<b>Execution Error; No peak found.</b>	No signal peak was found within the defined parameters of the search. (Note: for ESA/PSA compatibility, the Swept SA measurement uses 780 for this error number; all other measurements use -220)
-200	<b>Execution error; No ranges are defined. Activate a range.</b>	There are no active ranges in the range table. You will need to activate at least one range
-200	<b>Execution Error; Preselector centering failed</b>	Algorithm failed to center the preselector. This maybe caused by the signal peak being too low in amplitude, or it could be due to excessive CW input signal, alignment error, or hardware failure
-200	<b>Execution Error; Signal not stable enough to track</b>	The signal that you have selected to track is changing too much for the function to track it properly
-200	<b>Execution Error; Store ref trace before turning on Normalize</b>	The Reference trace data must be stored in the Ref trace before you turn on the Normalization function
-200	<b>Execution error; Sync word was not found.</b>	NADC & PDC: In an EVM measurement, the sync word is not found and the synchronization cannot be established when Sync Word is selected in the Burst Sync menu.  Flexible Digital Demodulation: The sync word cannot be detected because of inappropriate parameter settings or incorrect signal
-200	<b>Execution error; Trace file contains no compatible traces.</b>	The trace file may have been created by another version of the Phase Noise personality, which uses a different trace format that is incompatible with the version you are running. Please check that you are running the most up-to-date version of the personality

Instrument Messages  
Event Messages

<b>Err#</b>	<b>Message</b>	<b>Verbose/Correction Information</b>
-200	<b>Execution error; Trace file created by incompatible version of Phase Noise App</b>	The trace file may have been created by another version of the Phase Noise personality, which uses a different trace format that is incompatible with the version you are running. Please check that you are running the most up-to-date version of the personality
-200	<b>Function not available before Marker Zoom is performed</b>	Function not available before perform Marker Zoom
-200	<b>Must perform Scan before do Search</b>	Cannot perform Search as the trace data is empty
-200	<b>No marked signal</b>	Cannot perform the selected function because no signal was marked. You must mark the peak of interest before selecting the function
-200	<b>No Measure At Marker Added to Signal List</b>	No signal peak was added into Signal List as there is no valid measure to Marker result. You must perform Measure at Marker before selecting Measure At Marker --> List
-200	<b>No Peak Added to Signal List</b>	No signal peak was added from the Search to Signal List as no signal peaks were found within the defined parameters of the search criteria
-200	<b>Signal List is Empty</b>	Cannot perform the selected function because the signal list contains no data
-200	<b>Signal List is Full</b>	Cannot perform the selected function because the signal list is full. Please clear the list
-200	<b>Signal Selected is not in the Signal List</b>	The signal selected is not the list. You only can perform the operation on signal that is already available in the list
-201	<b>Invalid while in local</b>	The command cannot be executed while the instrument in Local control
-202	<b>Settings lost due to rtl</b>	A "return to local" control was forced and some settings were lost as a result of this
-203	<b>Command protected</b>	The command could not be executed because it is disabled. It was disabled by licensing or password protection
-203	<b>Command protected; feature not licensed</b>	The specified feature, for example "N9073A-TR2" is not licensed. The license may have expired. You cannot use it until you obtain a license
-210	<b>Trigger error</b>	A trigger error has occurred, but the exact problem cannot be specifically identified
-211	<b>Trigger ignored</b>	A GET, *TRG or other triggering signal was received, but was ignored because of timing considerations. For example, maybe the instrument was not ready to respond when the command was received
-212	<b>Arm ignored</b>	An arming signal was received, but it was ignored
-213	<b>Init ignored</b>	An initiate trigger/sweep request was received and ignored, because another measurement was already in progress

<b>Err#</b>	<b>Message</b>	<b>Verbose/Correction Information</b>
-214	<b>Trigger deadlock</b>	The trigger source for the initiation of a measurement is set to GET, and the following measurement query was received. The measurement cannot be started until a GET is received, but the GET would cause an INTERRUPTED error
-215	<b>Arm deadlock</b>	The arm source for the initiation of a measurement is set to GET and the following measurement query is received. The measurement cannot be started until a GET is received and the GET would cause an INTERRUPTED error
-220	<b>Parameter error</b>	A problem was found with a program data element. The exact problem cannot be specifically identified
-221	<b>Settings conflict;</b>	There are many types of settings conflict errors. For full details, see “ <b>-221 Settings Conflict Errors</b> ” on page 89
-222	<b>Data out of range;</b>	A data element was found but the instrument could not be set to that value because it was outside the range defined for the command. A descriptive message may be appended, such as “clipped to upper limit”
-222	<b>Data out of Range; clipped to source max/min</b>	A source parameter has been entered that exceeds the range of the selected source. The parameter has been clipped to match the range of the source
-222	<b>Data out of range; Invalid list data</b>	You tried to use a trace that has a number of sweep points that differs from the current sweep points setting
-222	<b>Data out of range; Two entries already exist at this x-axis value.</b>	When entering values for limit lines, you cannot have more than two Y-axis (amplitude) values entered for a specific X-axis (frequency) value
-223	<b>Too much data</b>	A data element (of block, expression, array type, or string type) had more data than allowed by the command, or by the available memory
-223	<b>Too much data; 200 spurs found. Additional spurs ignored.</b>	There are too many spurs for the table (the limit is 200), and any additional spurs that are found will be ignored
-224	<b>Illegal parameter value</b>	An exact data value (from a list of the allowed values) was required, but not found. See the specific feature description for information about the expected parameter values
-224	<b>Illegal parameter value; &lt;Value&gt; invalid. Fractional values are not allowed.</b>	The seconds parameter of an LXI time may not contain a fractional portion. For example 123456789.0 is valid, but 123456789.1 is not valid
-224	<b>Illegal parameter value; &lt;value&gt; out of range.</b>	The value does not fall within the valid range



<b>Err#</b>	<b>Message</b>	<b>Verbose/Correction Information</b>
-224	Illegal parameter value; Exceeding the max list length	The list parameters have a maximum allowed length. You are trying to set a length longer than the maximum
-224	Illegal parameter value; Gated FFT is not available while Sweep Type is set to Swept	The gated FFT function is not available if you have selected the swept type of sweep. You must select the FFT sweep type
-224	Illegal parameter value; Gated LO is not available while Sweep Type is set to FFT	The FFT sweep type moves the LO frequency in steps, so the gated LO function is not available if you have selected FFT sweep
-224	Illegal parameter value; Gated Video is not available while Sweep Type is set to FFT	The gated video function is not available if you have selected the FFT sweep type
-224	Illegal parameter value; Illegal identifier <identifier>. This value may already be in use.	The value for the LXI LAN identifier parameter must be unique (that is, LAN0 and LAN7 must have different identifier strings)
-224	Illegal parameter value; Index out of range	When querying the LXI Event Log or the Servo Log, an index may be used to look at a specific entry. This error occurs if the index provided does not point to a valid entry
-224	Illegal parameter value; Invalid list length	You are trying to set some list measurement settings, but the multiple lists that you sent had differing lengths. The number of settings must be consistent from list to list
-224	Illegal parameter value; LXI Event <event> already exists.	This error occurs when you try to add an LXI Event that has already been added
-224	Illegal parameter value; LXI Event <event> contains illegal characters.	When a new LXI Event is created, it may not use the comma, semicolon, or newline characters. All other printable ASCII characters are valid
-224	Illegal parameter value; LXI Event <event> does not exist.	The requested event has not been added yet

Instrument Messages  
Event Messages

Err#	Message	Verbose/Correction Information
-224	Illegal parameter value; Measurement not available	You tried to turn on a measurement that is not available in the current mode
-224	Illegal parameter value; This instrument is always DC coupled	You cannot set AC coupling in this instrument
-224	Illegal parameter value; This model is always AC coupled	You cannot set DC coupling in this analyzer
-225	Out of memory	There is not enough memory to perform the requested operation
-225	Out of memory; Insufficient resources to load Mode <mode name>	If you attempt to load a mode via SCPI that will exceed memory capacity, the Mode does not load and this message is returned. "mode name" is the SCPI parameter for the Mode in question (for example, SA for Spectrum Analyzer Mode.) You can free up resources using the <b>System, Power On, Configure Applications</b> menu
-225	Out of memory; Memory limit caused Data Acquisition to be truncated	
-226	List not same length	You are using the LIST structure, but have individual lists of differing lengths
-230	Data corrupt or stale;	A legal data element was found, but it could not be used because the data format or the data structure was not correct. This could occur if a new measurement had been started but had not completed
-230	Data corrupt or stale; Measurement data is not available	Measurement data not available. The measurement that you are trying to get data from must be the current active measurement. Maybe you have not initiated the measurement, or it has not completed all the sweeps/averages needed
-230	Data corrupt or stale; Trace contains no data.	Trace cannot be displayed because currently there is no data assigned to it. Use the functions under the <b>Trace/Detector</b> menu, or load a previously saved trace, to assign data to the trace
-230	Data corrupt or stale; Unable to load state from file	There is something wrong with the state data in the desired file. Maybe the file is corrupt, or it is from an instrument/version that is not recognized by the current instrument
-231	Data questionable	Indicates that the measurement accuracy is suspect
-232	Invalid format	A data element was found but it could not be used because the data format or the data structure was not correct
-232	Invalid format; Map information not loaded	Instrument failed to load the burst mapping information from the selected file

Instrument Messages  
Event Messages

Err#	Message	Verbose/Correction Information
-233	Invalid version	A legal data element was found but could not be used because the version of the data is incorrect. For example, state data changes as new instrument features are added, so old state files may not work in an instrument with a newer version of software
-240	Hardware error	A legal program command or query could not be executed because of a hardware error. The exact problem cannot be specifically identified
-240	Hardware error; See details in Windows Event Log under SA	The internal data acquisition system detected a problem at startup and logged the details in the Windows Event Log
-241	Hardware missing	The operation could not be performed because of missing hardware; perhaps the optional hardware is not installed
-241	Hardware missing; Input not available	The hardware required is not part of this model or the option is not installed
-241	Hardware missing; Internal preamp not available at all frequency points	The Internal Preamp is currently turned on, but the measurement is being performed completely or partially outside the range of the preamp. It is recommended that the user turns preamp off to ensure consistent results across the entire measurement
-241	Hardware missing; not available for this model number	The hardware required is not part of this model
-241	Hardware missing; Option not installed	The optional hardware is not installed
-250	Mass storage error;	A problem was found with the mass storage device (memory, disk drive, etc.). The exact problem cannot be specifically identified
-250	Mass storage error; Access denied	Access is denied
-250	Mass storage error; Bad path name	The specified path is invalid
-250	Mass storage error; Can only import single trace .csv files	Trace files containing multiple traces can not be imported. However, if you need to recall multiple traces you can use the <b>Save</b> and <b>Recall</b> functions, rather than the Import and Export functions
-250	Mass storage error; Can only load an Antenna Unit into Correction 1	The only Correction register that supports Antenna Units is number 1. You have attempted to load an Ampcor file that contains antenna units into another register
-250	Mass storage error; Cannot make	The directory or file cannot be created
-250	Mass storage error; Different Antenna Unit already in use	Attempt to import Corrections file with Antenna Unit that differs from an in-use correction

Instrument Messages  
Event Messages

Err#	Message	Verbose/Correction Information
-250	Mass storage error; Directory not found	The system cannot find the path specified
-250	Mass storage error; Failed to Load trace. Bad file format.	The load trace operation could not be completed, as the input file was not in the expected format. You can only load traces that were previously saved using the <b>Save, Trace</b> feature
-250	Mass storage error; File <filename> wrong type	Attempt to import a data file that is not the proper type for this operation
-250	Mass storage error; File <filename> and instrument version mismatch	While opening a file, there was a mismatch between file version or model number with instrument version or model number. The import still tried to load as much as possible, but you should check it closely
-250	Mass storage error; File contains incorrect data for this operation	There is a mismatch between the file data type of the file specified and the destination indicated. For example, a correction set cannot be loaded/imported into a limit line
-250	Mass storage error; File empty	Cannot save trace because it contains no data. Check that the trace is turned on and contains some valid data
-250	Mass storage error; Invalid register number for *SAV or *RCL Mass Storage error	You have used the *SAV command to save a state to a non existent state register.  Or You have used the *RCL command to recall a state register that wasn't previously saved with the *SAV command
-250	Mass storage error; Lock violation	The process cannot access the file because another process has locked a portion of the file
-250	Mass storage error; Mkr Table must be on to save Mkr Table as Meas Results	You have to have a Marker Table on the screen before you can save it. Turn on the Marker Table and try again
-250	Mass storage error; No file names available	Attempt to use the auto file name generation when all 10,000 file names are taken
-250	Mass storage error; Open failed	The system cannot open the device or file specified. This could be because the storage media is full, or possibly due to a filename error. If using an external storage device, check that the device is properly formatted
-250	Mass storage error; Pk Table must be on to save Pk Table as Meas Results	You must have a Peak Table on the screen before you can save it. Turn on the Peak Table and try again
-250	Mass storage error; Read fault	The system cannot read from the specified device

Instrument Messages  
Event Messages

<b>Err#</b>	<b>Message</b>	<b>Verbose/Correction Information</b>
-250	Mass storage error; Register <number> empty	Attempt to recall a register with nothing in it
-250	Mass storage error; Sharing violation	The process cannot access the file because it is being used by another process
-250	Mass storage error; Spectrogram must be on to save as Meas Results	You must have a Spectrogram on the screen before you can save it. Turn on the Spectrogram and try again
-250	Mass storage error; Too many open files	The system cannot open the file
-250	Mass storage error; Write fault	The system cannot write to the specified device
-252	Missing media	A legal command or query could not be executed because of missing media
-253	Corrupt media	A removable media was found to be bad or incorrectly formatted. Any existing data on the media may have been lost
-254	Media full	A legal command/query could not be executed because the media was full
-255	Directory full	A legal command or query could not be executed because the media directory was full
-256	File name not found;	A legal command or query could not be executed because the file name was not found in the specified location
-257	File name error;	A legal command or query could not be executed because there was an error with the file name on the device media. For example, maybe you tried to copy to a duplicate file name
-257	File name error; Allowable extension is .csv	You are using the wrong type of file extension for the current data/file type
-257	File name error; Allowable extension is .png	You are using the wrong type of file extension for the current data/file type
-257	File name error; Allowable extension is .state	You are using the wrong type of file extension for the current data/file type
-257	File name error; Invalid file name	The filename, directory name, or volume label syntax is incorrect
-257	File name error; name too long	
-258	Media protected	A legal command or query could not be executed because the media was protected. For example, the write-protect was set

Instrument Messages  
Event Messages

<b>Err#</b>	<b>Message</b>	<b>Verbose/Correction Information</b>
-260	<b>Expression error</b>	An error was found with an expression type of data element. The exact problem cannot be specifically identified
-261	<b>Math error in expression</b>	An expression that has legal syntax could not be executed because of a math error. For example, maybe you are dividing by zero
-270	<b>Macro error</b>	Indicates that a macro-related execution error occurred
-271	<b>Macro syntax error</b>	Indicates a syntax error within the macro definition
-272	<b>Macro execution error</b>	Indicates that a syntactically legal macro program data sequence could not be executed due to some error in the macro definition
-273	<b>Illegal macro label</b>	Indicates that the macro label defined in the *DMC command was a legal string syntax, but could not be accepted
-274	<b>Macro parameter error</b>	Indicates that the macro definition improperly used a macro parameter placeholder
-275	<b>Macro definition too long</b>	Indicates that a syntactically legal macro program data sequence could not be executed because the string or block contents were too long for the device to handle
-276	<b>Macro recursion error</b>	Indicates that a syntactically legal macro program data sequence could not be executed because the device found it to be recursive
-277	<b>Macro redefinition\ not allowed</b>	Indicates that a syntactically legal macro label in the *DMC command could not be executed because the macro label was already defined
-278	<b>Macro header not found</b>	Indicates that a syntactically legal macro label in the *GMC? query could not be executed because the header was not previously defined
-280	<b>Program error</b>	There was an execution error in a down-loaded program. The exact problem cannot be specifically identified
-281	<b>Cannot create program</b>	Indicates that an attempt to create a program was unsuccessful. A reason for the failure might include not enough memory
-282	<b>Illegal program name</b>	The name used to reference a program was invalid; for example, redefining an existing program, deleting a nonexistent program, or in general, referencing a nonexistent program
-283	<b>Illegal variable name</b>	An attempt was made to reference a nonexistent variable in a program
-284	<b>Program currently running</b>	Certain operations dealing with programs may be illegal while the program is running; for example, deleting a running program might not be possible
-285	<b>Program syntax error</b>	Indicates that a syntax error appears in a downloaded program. The syntax used when parsing the downloaded program is device-specific
-286	<b>Program runtime error</b>	
-290	<b>Memory use errors</b>	
-291	<b>Out of memory</b>	

Instrument Messages  
Event Messages

<b>Err#</b>	<b>Message</b>	<b>Verbose/Correction Information</b>
-292	Referenced name does not exist	
-293	Referenced name already exists	
-294	Incompatible type	Indicates that the type or structure of a memory item is inadequate

## -100 to -199, Command Errors

<b>Err#</b>	<b>Message</b>	<b>Verbose/Correction Information</b>
-100	<b>Command error</b>	There is a problem with the command. The exact problem cannot be specifically identified
-101	<b>Invalid character</b>	An invalid character was found in part of the command
-102	<b>Syntax error</b>	An unrecognized command or data type was found, for example a string was received for a command that doesn't accept strings
-103	<b>Invalid separator</b>	The command was supposed to contain a separator but we found an illegal character. For example, the semicolon was omitted after a command string
-104	<b>Data type error</b>	A data type differed from what was expected. For example, numeric or string data was expected, but block data was found
-105	<b>GET not allowed</b>	A Group Execute Trigger was received within a program message
-108	<b>Parameter not allowed</b>	More parameters were received than were expected for the command. For example, the *ESE common command only accepts one parameter, so sending *ESE 0,1 is not allowed
-109	<b>Missing parameter</b>	Fewer parameters were received than required for this command
-110	<b>Command header error</b>	This is a general error that is generated when a problem is found in a command header, but no more specific information is available
-111	<b>Header separator error</b>	An illegal character was found in a command where a separator was expected
-112	<b>Program mnemonic too long</b>	The command contains a keyword that has more than twelve characters
-113	<b>Undefined header</b>	The command meets the SCPI syntax requirements, but is not valid in the current measurement environment
-114	<b>Header suffix out of range</b>	The value of a numeric suffix that is attached to a program mnemonic makes the header invalid. (A suffix is usually units, like Hz or DB)
-115	<b>Unexpected number of parameters</b>	The number of parameters received does not correspond to the number of parameters expected.
-120	<b>Numeric data error</b>	An error was found in a data element that appears to be numeric. The exact problem cannot be specifically identified
-121	<b>Invalid character in number</b>	A character was found that is not valid for the data type. For example, an alpha in a decimal numeric or a "9" in octal data
-123	<b>Exponent too large</b>	The magnitude of an exponent was greater than 32000
-124	<b>Too many digits</b>	The mantissa of a decimal-numeric contained more than 255 digits, excluding leading zeros
-128	<b>Numeric data not allowed</b>	A legal numeric data element was found, but that is not a valid element at this position in the command



Instrument Messages  
Event Messages

<b>Err#</b>	<b>Message</b>	<b>Verbose/Correction Information</b>
-130	<b>Suffix error</b>	A problem was found in a suffix (units). The exact problem cannot be specifically identified
-131	<b>Invalid suffix</b>	There is a syntax problem with the suffix. You need to use the suffix (units) that are allowed by this command
-134	<b>Suffix too long</b>	The suffix contained more than twelve characters
-138	<b>Suffix not allowed</b>	A suffix was found after a numeric element that does not allow suffixes (units)
-140	<b>Character data error</b>	A problem was found with a character data element. The exact problem cannot be specifically identified
-141	<b>Invalid character data</b>	Either the character data element contains an invalid character or the element itself is not valid for this command
-144	<b>Character data too long</b>	The character data element contains more than twelve characters
-148	<b>Character data not allowed</b>	A character data element that you sent is valid, but it is not allowed at this point in the parsing
-150	<b>String data error</b>	A problem was found with a string data element. The exact problem cannot be specifically identified
-151	<b>Invalid string data</b>	A string type of data element was expected, but it is invalid for some reason. For example, an END message was received before the terminal quote character
-158	<b>String data not allowed</b>	A string data element that you sent is valid, but it is not allowed at this point in the parsing
-160	<b>Block data error</b>	A problem was found with a block data element. The exact problem cannot be specifically identified
-161	<b>Invalid block data</b>	A block data element was expected, but it was invalid. For example, an END message was received before the end length was satisfied
-168	<b>Block data not allowed</b>	A legal block data element was found, but it is not allowed at this point in the parsing
-170	<b>Expression error</b>	A problem was found with an expression data element. The exact problem cannot be specifically identified
-171	<b>Invalid expression</b>	An expression data element is not valid. For example, there may be unmatched parentheses or an illegal character
-178	<b>Expression data not allowed</b>	A legal expression data was found, but it is not allowed at this point in the parsing
-180	<b>Macro error</b>	A problem was found with a macro element. The exact problem cannot be specifically identified
-181	<b>Invalid outside macro definition</b>	Indicates that a macro parameter placeholder was encountered outside of a macro definition

Instrument Messages  
Event Messages

<b>Err#</b>	<b>Message</b>	<b>Verbose/Correction Information</b>
-183	<b>Invalid inside macro definition</b>	Indicates that the program message unit sequence, sent with a *DDT or *DMC command, is syntactically invalid
-184	<b>Macro parameter error</b>	Indicates that a command inside the macro definition had the wrong number or type of parameters

0 Error

<b>Err#</b>	<b>Message</b>	<b>Verbose/Correction Information</b>
0	<b>No error</b>	The queue is empty. Either every error in the queue has been read, or the queue was cleared by power-on or *CLS

## Condition Messages

Condition messages are displayed in the STATUS message area in the bottom right of the display. Condition messages are classified as either “Errors” or “Warnings.” In the tables in this section, an E in the **Error or Warning** column means that an error is displayed on the front panel and sent out to SCPI when this condition is detected. A W in this column means that a Warning is displayed on the front panel, but nothing is sent to SCPI.

For each Condition Message, there is a corresponding bit in one of the SCPI Status Registers. These bits are listed in the tables below. Some messages exist **only** as status bits; for these messages the **Error or Warning** column entry specifies “status bit only”.

### Condition errors 1 to 99, Calibration

These errors correspond to the `STATUS:QUESTIONABLE:CALIBRATION` register. Since this register is fanned out to three sub-registers, with summary bits in the main `STATUS:QUESTIONABLE:CALIBRATION` register, each sub-register has its own range of error numbers.

#### Condition Errors 6 to 34, Calibration Skipped

This series of errors corresponds to the bits in the `STATUS:QUESTIONABLE:CALIBRATION:SKIPPED` sub-register. The second column in the table shows the corresponding bit in that register.

An event with the error number shown in the table means the condition has been detected. When the condition is cleared, an event with the error number plus 1000 is generated. These error numbers can be viewed in the Show Errors screen, along with the DETECTED and CLEARED indicators.

For example, error 6 indicates that the “RF Alignment being skipped” condition has been detected, and error 1006 indicates that failure has been cleared.

This register is summarized as bit 11 of the `STATUS:QUESTIONABLE:CALIBRATION` register, as described in section **“Condition Errors 36 to 64, Calibration Needed or Failed” on page 116**.

Err#	Bit in status register	Message	Error or Warning	More Information
6	0	Align RF Skipped	W	
8	1	unused		
10	2	unused		
12	3	unused		
14	4	unused		
16	5	unused		

Err#	Bit in status register	Message	Error or Warning	More Information
18	6	unused		
20	7	unused		
22	8	unused		
24	9	unused		
26	10	unused		
28	11	unused		
30	12	unused		
32	13	unused		
34	14	unused		

### Condition Errors 36 to 64, Calibration Needed or Failed

This series of errors corresponds to the bits in the `STATUS:QUESTIONABLE:CALIBRATION` register. The second column in the table shows the corresponding bit in that register.

An event with the error number shown in the table means the condition has been detected. When the condition is cleared, an event with the error number plus 1000 is generated. These error numbers can be viewed in the Show Errors screen, along with the DETECTED and CLEARED indicators.

For example, error 42 indicates that the “RF Alignment Failure” condition has been detected, and error 1042 indicates that failure has been cleared.

Several bits in this register are “summary bits” for registers at a lower level. There are no error messages associated with these bits; they exist only as status bits, which can be read with a `STATUS:QUESTIONABLE:CALIBRATION?` event query or a `STATUS:QUESTIONABLE:CALIBRATION:CONDITION?` query.

Note that these summary bits summarize the state and history of the event registers at the lower level. This is true even for bits in the `STATUS:QUESTIONABLE:CALIBRATION` condition register. This means that:

- The summary bits read by the `STATUS:QUESTIONABLE:CALIBRATION:CONDITION?` query are true if any event bits are set in any of the `:CALIBRATION` sub-registers `:SKIPPed`, `:EXTENDED:NEEDED` or `:EXTENDED:FAILURE`.
- The summary bits read by the `STATUS:QUESTIONABLE:CALIBRATION?` event query are true if any event bit has undergone a false-to-true transition with the PTRansition filter set, or a true-to-false transition with the NTRansition filter set, in any of the `:CALIBRATION` sub-registers `:SKIPPed`, `:EXTENDED:NEEDED` or `:EXTENDED:FAILURE`.

Thus, the summary bits **cannot** be used to determine the current state of a lower level condition bit; only the state and history of the lower level event bits.

This register is itself summarized as bit 8 of the `STATUS:QUESTIONABLE` register, as described in the section **“Condition Errors 601 to 699, Error Summaries” on page 133.**

Err#	Bit in status register	Message	Error or Warning	More Information
36	0	unused		
38	1	unused		
40	2	TG Alignment Failure	E	
42	3	RF Alignment Failure	E	
44	4	IF Alignment Failure	E	
46	5	LO Alignment Failure	E	
48	6	ADC Alignment Failure	E	
50	7	FM Demod Alignment Failure	E	
52	8	Extended Align Needed Summary	status bit only	This bit is the summary bit for the <code>STATUS:QUESTIONABLE:CALIBRATION:EXTENDED:NEEDED</code> sub-register.
54	9	Extended Align Failure Summary	status bit only	This bit is the summary bit for the <code>STATUS:QUESTIONABLE:CALIBRATION:EXTENDED:FAILURE</code> sub-register.
56	10	unused		
58	11	Align Skipped Sum Summary	status bit only	This bit is the summary bit for the <code>STATUS:QUESTIONABLE:CALIBRATION:SKIPPED</code> sub-register.
60	12	Align Now, RF required	E	
62	13	unused		
64	14	Align Now, All required	E	In PSA, this was error 64

### Condition Errors 65 to 92, Calibration Needed (Extended)

This series of errors corresponds to the bits in the `STATUS:QUESTIONABLE:CALIBRATION:EXTENDED:NEEDED` sub-register. The second column in the table below shows the corresponding bit in that register.

An event with the error number shown in the table means the condition has been detected. When the condition is cleared, an event with the error number plus 1000 is generated. These error numbers can be viewed in the Show Errors screen, along with the DETECTED and CLEARED indicators.

For example, error 72 indicates that the “Input Attenuation not calibrated” condition has been detected, and error 1072 indicates that failure has been cleared.

This register is summarized as bit 8 of the `STATUS:QUESTIONABLE:CALIBRATION` register, as described in the section **“Condition Errors 36 to 64, Calibration Needed or Failed” on page 116**.

Err#	Bit in status register	Message	Error or Warning	More Information
65	0	unused		
66	1	<b>Align 9kHz-30MHz required</b>	E	An EMI conducted frequency range alignment is needed.
68	2	<b>Align 30MHz-1GHz required</b>	E	An EMI radiated frequency range alignment is needed.
72	4	<b>Input Attenuation not calibrated</b>	E	Corrected measurements have been requested and the required RF front-end setting of x dB has not been calibrated.
74	5	unused		
76	6	unused		
78	7	unused		
80	8	unused		
82	9	unused		
84	10	unused		
86	11	unused		
88	12	unused		
90	13	unused		
92	14	unused		

### Condition Errors 67 to 95, Calibration Failure (Extended)

This series of errors corresponds to the bits in the `STATUS:QUESTIONABLE:CALIBRATION:EXTENDED:FAILURE` sub-register. The second column in the table shows the corresponding bit in that register.

An event with the error number shown in the table means the condition has been detected. When the condition is cleared, an event with the error number plus 1000 is generated. These error numbers can be viewed in the Show Errors screen, along with the DETECTED and CLEARED indicators.

For example, error 71 indicates that the Characterize Preselector Failure has been detected, error 1071 indicates that failure has been cleared.

This register is summarized as bit 9 of the `STATUS:QUESTIONABLE:CALIBRATION` register, as described in the section **“Condition Errors 36 to 64, Calibration Needed or Failed” on page 116**.

Err#	Bit in status register	Message	Error or Warning	More Information
67	0	Align 9kHz to 30MHz failed	W	In PSA, this was error 13749
69	1	Align 30MHz to 1GHz failed	W	In PSA, this was error 13751
71	2	Characterize Preselector failure	W	The preselector characterization routine failed.
73	3	unused		
75	4	unused		
77	5	unused		
79	6	unused		
81	7	unused		
83	8	unused		
85	9	unused		
87	10	unused		
89	11	unused		
91	12	unused		
93	13	unused		
95	14	unused		

## Condition Errors 101 to 199, Measurement Integrity

This series of errors corresponds to the bits in the `STATUS:QUESTIONABLE:INTEGRITY` register. The second column in the table shows the corresponding bit in that register.

An event with the error number shown in the table means the condition has been detected. When the condition is cleared, an event with the error number plus 1000 is generated. These error numbers can be viewed in the Show Errors screen, along with the DETECTED and CLEARED indicators.

For example, error 141 indicates an Input Overload condition has been detected, error 1129 indicates that failure has been cleared.

Two bits in this register are “summary bits” for registers at a lower level. There are no error messages associated with these bits; they exist only as status bits, which can be read with a `STATUS:QUESTIONABLE:INTEGRITY?` event query or a `STATUS:QUESTIONABLE:INTEGRITY:CONDITION?` query.

Note that these summary bits summarize the state and history of the event registers at the lower level. This is true even for bits in the `STATUS:QUESTIONABLE:INTEGRITY` condition register. This means that:

- The summary bits read by the `STATUS:QUESTIONABLE:INTEGRITY:CONDITION?` query are true if any event bits are set in any of the `:INTEGRITY` sub-registers `:SIGNAL` or `:UNCALIBRATED`.
- The summary bits read by the `STATUS:QUESTIONABLE:INTEGRITY?` event query are true if any event bit has undergone a false-to-true transition with the PTRANSITION filter set, or a true-to-false transition with the NTRANSITION filter set, in any of the `:INTEGRITY` sub-registers `:SIGNAL` or `:UNCALIBRATED`.

Thus, the summary bits **cannot** be used to determine the current state of a lower level condition bit; only the state and history of the lower level event bits.

This register is itself summarized as bit 9 of the `STATUS:QUESTIONABLE` register, as described in the section [“Condition Errors 601 to 699, Error Summaries” on page 133](#).

Err#	Bit in status register	Message	Error or Warning	More Information
133	0	Signal Summary	status bit only	This bit is the summary bit for the <code>STATUS:QUESTIONABLE:INTEGRITY:SIGNAL</code> sub-register.
135	1	No Result	E	
135	1	No Result;Turn on MCE	E	To calculate Timing and Phase results in the Code Domain Power view of Mod Accuracy, the "Multi Channel Estimator" must be set to ON. Otherwise these results are invalid.



Instrument Messages  
Condition Messages

Err#	Bit in status register	Message	Error or Warning	More Information
135	1	No Result; Meas invalid with I/Q inputs	E	The current measurement does not support I/Q input; switch to the RF or another input or select a different measurement
137	2	unused		
139	3	Uncalibrated Summary	status bit only	This bit is the summary bit for the STATus:QUEStionable:INTEgrity:UNCalibrated sub-register.
141	4	Input Overload	E <sup>a</sup>	
141	4	Input Overload;ADC over range	E <sup>a</sup>	The signal at the input to the IF section is too high. You should increase the attenuation or lower the signal level.
141	4	Input Overload;I/Q ADC over range	E <sup>a</sup>	The I or Q input exceeds the ADC upper limit.
141	4	Input Overload;I/Q Voltage over range	E <sup>a</sup>	The input voltage on the I or Q channel exceeds the channel limit. In differential mode the over voltage may occur without causing an ADC overload, for example, if I is at +5.01 V and I-bar is at +5.0 the ADC will be in range but both I and I-bar will exceed the voltage limit.
141	4	Input Overload; RF Preselector Overload	E <sup>a</sup>	The level at the input of the MXE RF Preselector has exceeded tolerances, reduce the input level
143	5	unused		
145	6	unused		
147	7	Insufficient Data	E	
147	7	Insufficient Data; Incr. Demod Time	E	There is insufficient acquisition data to provide accurate metrics. You should increase the Demod Time to acquire enough data.
147	7	Insufficient Data; frequency list empty	E	A measurement was attempted with List frequency mode or a SCPI query of the frequency list table was made and the frequency list table is empty.
147	7	Insufficient Data; ENR table empty	E	A measurement was attempted or a SCPI query of an ENR table was made and there were no entries in the relevant ENR table (Common, Meas or Cal).
147	7	Insufficient Data; Loss table empty	E	A measurement is attempted or a SCPI query of a before or after loss table is made and there are no entries in the relevant loss table

Instrument Messages  
Condition Messages

Err#	Bit in status register	Message	Error or Warning	More Information
149	8	Meas Error		
151	9	Memory Error	E	
151	9	Memory Error;Shorten capture interval	E	A shortage of free memory related to longer capture intervals has occurred. The measurement is aborted and all results return invalid values
153	10	I/O Error	E	
153	10	I/O Error; Ext Source needs IP Addr	E	No IP address entered for external source and external LO control is ON.
155	11	Trig Error	E	
157	12	Invalid Data	Status bit only	This is the “invalid data indicator”, same as the “*” in the upper right corner of the screen. It means that the on-screen annotation does not match the on-screen data, usually because a measurement is pending after a settings change. There is no message in the status line and nothing in the history queue, but there IS an on-screen indication and a status bit.
159	13	Settings Alert	W	
159	13	Settings Alert;LO may overload IF	W	If the sweep type is Swept, the start frequency of the instrument is less than 10 MHz, and you put Swept IF Gain in Manual High, then a warning condition is generated and remains in effect as long as this condition exists.  In some older analyzers this was error 1109.
159	13	Settings Alert; Diff probe mismatch; <I Q I,Q>	W	The attenuation values of the two probes on the I and/or Q channels differ by too much for a valid differential reading.
159	13	Settings Alert; Acquisition truncated	W	In the Analog Demod mode, certain extreme settings combinations will result in a required acquisition length in excess of the capacity of the analyzer. Increase the AF Spectrum RBW or the RF Spectrum RBW, decrease the Channel BW, and/or decrease the Demod Waveform Sweep Time.

Err#	Bit in status register	Message	Error or Warning	More Information
159	13	Settings Alert; Analog Out settings conflict	W	The user has manually set the Analog Output under the Input/Output menu to a setting that conflicts with the current measurement. There will be no output on the Analog Out port until this conflict is resolved. In most cases, simply set Analog Out to Auto for the optimal setting.
159	13	Settings Alert; I/Q mismatch: <Differential Input Z Attenuation>	W	The impedance, differential, or attenuation settings for the I and Q channels do not match. For valid I+jQ measurements the impedance and differential settings should be the same on both channels and the attenuation should match within 1 dB
159	13	Settings Alert; Parm/data mismatch	W	For Bluetooth, the detected parameters did not match the data
159	13	Settings Alert; Src pwr ramp>ALC range	W	You have selected a Power Sweep range that exceeds the ability of the external Source to follow without changing mechanical attenuation. Lower the Power Sweep range.
159	13	Settings Alert; Sweep Rate Unavailable	W	The auto coupled sweep time exceeds the maximum allowed. Therefore, full amplitude accuracy cannot be attained. Please increase the RBW or reduce the span.
159	13	Settings Alert; Span:RBW Ratio too big	W	The chosen large ratio of span to RBW is not possible. Please reduce the span or increase the RBW and/or FFT Width.
161	14	Setting Modified	E	
161	14	Setting Modified; Filter not applied	E	The filter you have selected is larger than the sampling frequency. You should select a different filter.

- a. The Input Overload error is not reported to the SCPI queue unless the :SYSTEM:ERROR:OVERload ON command has been issued, however it always sets the status bit. For details of the :SYSTEM:ERROR:OVERload command, see any X-Series User's & Programmer's Reference.

## Condition Errors 201 to 299, Signal Integrity

This series of errors corresponds to the bits in the STATUS:QUESTIONable:INTEgrity:SIGNal sub-register. The second column in the table shows the corresponding bit in that register.

An event with the error number shown in the table means the condition has been detected. When the condition is cleared, an event with the error number plus 1000 is generated. These error numbers can be viewed in the Show Errors screen, along with the DETECTED and CLEARED indicators.

For example, error 207 indicates a Burst Not Found condition has been detected, error 1207 indicates that failure has been cleared.

This register is summarized as bit 0 of the `STATUS:QUESTIONABLE:INTEGRITY` register, as described in the section **“Condition Errors 101 to 199, Measurement Integrity” on page 120.**

Err#	Bit in status register	Message	Error or Warning	More Information
203	0	unused	E	
205	1	unused	E	
207	2	<b>Burst Not Found</b>	E	<p>The burst signal cannot be detected because of inappropriate parameter settings or incorrect signal.</p> <p>An in appropriate parameter setting could cause the signal to be partially, rather than fully, on the display, Burst Search Threshold and/or Burst Search Length may need to be adjusted.</p> <p>An incorrect signal could have either insufficient power, the rising or falling edges cannot be detected, or the burst is less than 126 microseconds.</p> <p>Carrier signal is not actually bursted.</p> <p>W-CDMA: Either the signal being analyzed has insufficient power, the rising or falling edges cannot be detected, or the burst is less than 126 microseconds.</p> <p>W-CDMA: Cannot synchronize measurement with PRACH channel for Power Control measurement, because the signal cannot be found. Make sure PRACH is present in the W-CDMA uplink signal, and that the preamble signature and scramble code are set correctly.</p> <p>GSM: Data was acquired but a GSM burst was not found, with the timeslot mode disabled.</p> <p>NADC, PDC: A valid burst is not found when the Device is MS.</p> <p>1xEV-DO: Data was acquired but a 1xEV burst was not found, with the timeslot mode disabled.</p> <p>Bluetooth: The burst that has been found does not correspond to the currently selected Bluetooth packet type (the burst length may be too short).</p> <p>WLAN: The instrument cannot find a valid WLAN burst. You may need to extend the search length.</p> <p>In PSA, this error was reported as one of the following error numbers: 10772, 13104, 10160, 10286, 10420, 10454, 10614, 10904, 10928, 13074, 10287</p>

Instrument Messages  
Condition Messages

Err#	Bit in status register	Message	Error or Warning	More Information
207	2	Burst not found;with selected Time Slot	E	The selected timeslot does not contain the expected burst.
209	3	Timing Error	E	
209	3	Timing Error;No time ref pilot burst	E	The pilot burst used for time reference is not active.
211	4	Carrier(s) incorrect or missing	E	In PSA, this error was reported as one of the following error numbers: 10165, 10173, 10178, 10419, 10421, 10535, 10560, 10642, 10648, 10650, 10960
213	5	Freq Out of Range	E	
213	5	Freq Out of Range; System input (IF)	E	One or more system input frequencies are out of range. If using a frequency list, check that all entries are valid for current measurement mode.
213	5	Freq Out of Range; External LO	E	One or more external LO frequencies are out of range. Check that the LO frequency limits are set correctly and check the entered measurement frequencies and measurement mode.
215	6	Sync Error	E	W-CDMA: Cannot sync DPCCH pilot.  Cannot synchronize measurement with DPCCH pilot for Power Control measurement, because the pilot signal cannot be found. Make sure DPCCH is present in the W-CDMA uplink signal, and that the slot format and scramble code are set correctly.
215	6	Sync Error;No pilot burst	E	There is no Pilot burst detected.
215	6	Sync Error;Sync code not found	E	Synchronization code is not found in the measured time slot.
215	6	Sync Error;No freq ref pilot burst	E	The pilot burst used for frequency reference is not active.
215	6	Sync Error;Midamble sync fail	E	Failed to find the uplink slot, which caused the synchronization with the Midamble to fail.
215	6	Sync Error;Preamble length zero	E	Burst type is "Data" or "Preamble" and the measurement cannot find a Preamble

Instrument Messages  
Condition Messages

Err#	Bit in status register	Message	Error or Warning	More Information
217	7	Demod Error	E	<p>This error is normally generated because of one of the following reasons:</p> <ol style="list-style-type: none"> <li>1. There is no carrier signal.</li> <li>2. Walsh channels other than the pilot are active.</li> <li>3. There is some other modulation problem that will prevent the measurement from being made.</li> </ol> <p>This problem must be corrected before the measurement can continue.</p> <p>cdma 2000 &amp; W-CDMA: Cannot correlate to the input signal and no active channel is found. (from composite EVM measurement) An active channel must meet the default threshold criteria that it is within 20 dB of the highest power code channel. The threshold can be changed using the active set threshold function in the Meas Setup menu.</p> <p>cdmaOne: A correlation failure with the pilot CDMA channel occurred during synchronous demodulation.</p> <p>1xEV-DO: Cannot correlate to the input signal and no active channel is found. (from composite EVM measurement) An active channel must meet the default threshold criteria that it is within 20 dB of the highest power code channel. The threshold can be changed using the active set threshold function in the Meas Setup menu.</p> <p>In PSA, this error was reported as one of the following error numbers: 10872, 10962, 13070, 10228, 10768</p>
217	7	Demod Error;Can't correlate	E	<p>Cannot correlate to the input signal and no active channel is found. (from composite EVM measurement) An active channel must meet the default threshold criteria that it is within 20 dB of the highest power code channel. The threshold can be changed using the active set threshold function in the Meas Setup menu.</p>
217	7	Demod Error;Data interval too short	E	<p>There are not enough input I/Q pairs for the measurement calculation. This may be caused by an incorrect data capture.</p>
217	7	Demod Error;No active channel	E	<p>There is no active channel detected.</p>
217	7	Demod Error;Not an active slot	E	<p>There is no active slot detected.</p>

Instrument Messages  
Condition Messages

Err#	Bit in status register	Message	Error or Warning	More Information
217	7	Demod Error;No full subframe found	E	No sub-frame or only part of one sub-frame is detected.
217	7	Demod Error;Muxed bits not found	E	Multiplexed Data Demod Bits are not generated even though Data channel is selected, because all 16 data code channels are not active
217	7	Demod Error;Acq Time too short	E	For Bluetooth, the detected packet type doesn't match the captured packet type because the payload start, end or data could not be found.
219	8	Signal Too Noisy	E	NADC & PDC: The valid EVM measurement cannot be performed, because the input signal is too noisy. GSM & EDGE: In a GSM measurement, indicates that a burst could not be found in a signal that appears noisy. In PSA, this error was reported as one of the following error numbers: 10702, 10824, 10906, 10930, 13024, 10626, 111
221	9	Slot Error	E	
221	9	Slot error;No active slot found	E	No valid active slot found in captured data, or no active slot found in captured interval. Synchronization may succeed and pilot found when this message is issued, but no results are included in peak/average calculation.
221	9	Slot Error; No idle slot found	E	No valid idle slot found in captured data, or no idle slot found in captured interval. Synchronization may succeed and pilot found when this message is issued, but no results are included in peak/average calculation.
223	10	unused	E	
225	11	unused	E	
227	12	unused	E	
229	13	unused	E	
231	14	unused	E	

### Condition Errors 301 to 399, Uncalibrated Integrity

This series of errors corresponds to the bits in the `STATUS:QUESTIONABLE:INTEGRITY:UNCALIBRATED` sub-register. The second column in the table shows the corresponding bit in that register.

Instrument Messages  
Condition Messages

An event with the error number shown in the table means the condition has been detected. When the condition is cleared, an event with the error number plus 1000 is generated. These error numbers can be viewed in the Show Errors screen, along with the DETECTED and CLEARED indicators.

For example, error 301 indicates a Meas Uncal condition has been detected, error 1301 indicates that failure has been cleared.

This register is summarized as bit 3 of the `STATUS:QUESTIONABLE:INTEGRITY` register, as described in the section **“Condition Errors 101 to 199, Measurement Integrity” on page 120.**

Err#	Bit in status register	Message	Error or Warning	More Information
301	0	Meas Uncal	W	
303	1	Signal ID on	W	
305	2	No Long Code Phase	W	
307	3	AC coupled: Accy unspec'd <10 MHz	W	AC input coupling will function at lower frequencies, but the performance is not specified below 10 MHz.
309	4	User cal	W	



Instrument Messages  
Condition Messages

Err#	Bit in status register	Message	Error or Warning	More Information
309	4	User Cal; Cal invalidated	E,W	<p>The existing user cal has been invalidated for one of the following reasons:</p> <p><b>Frequency:</b> Setting the frequency outside the current valid user cal set (for example: If the current sweep range is 2 to 3GHz, then setting the start frequency to 1.9 GHz will invalidate the current user cal. Other frequency changes that will invalidate the user cal are:</p> <ul style="list-style-type: none"> <li>• If the cal was performed at a fixed frequency and you change this frequency.</li> <li>• If you are in "Freq List" mode and you change it to extend beyond the current user cal range. In this case you will see an error message.</li> </ul> <p><b>DUT Type:</b> If the DUT Type parameter changes, causing the measurement frequencies to be pushed outside the current cal.</p> <p>Attenuation: If an attenuation setting is selected but has not been calibrated.</p> <p>Preamp: If set to condition different from current cal settings, for example: if calibrated with the preamp on, turning it off will invalidate the cal.</p> <p><b>Points:</b> Changing the number of measured frequency points can make the stored preselector offsets become inaccurate and hence invalidate the calibration. This occurs when the following conditions exist:</p> <ul style="list-style-type: none"> <li>• A successful calibration has been performed.</li> <li>• Some measured freq points are &gt; 3.6 GHz.</li> <li>• The new points &gt; 3.6 GHz are located more than 50 MHz away from the current calibration points.</li> </ul>
309	4	User Cal; Freq outside cal range	E	<p>The existing user cal has been invalidated because the current measurement frequencies lie partially or wholly outside the range of frequencies used for user-cal. (UNCAL)</p>
309	4	User Cal; Cal will be interpolated	W	<p>The measurement frequency range has been changed such that it is a subset of the calibrated range. (~CAL)</p>

Instrument Messages  
Condition Messages

Err#	Bit in status register	Message	Error or Warning	More Information
309	4	User Cal; Adjusted for new RBW	W	The measurement RBW has been changed since the last calibration (~CAL)
311	5	Calibration	W	
311	5	Calibration; ENR table extrapolated	W	One or more calibration or measurement frequency points exceed the currently loaded Cal or Meas ENR Table frequency ranges. The corresponding ENR table's lowest frequency ENR value will be re-used for frequencies less than the table range, and the highest frequency ENR value will be re-used for frequencies greater than the table range.  (~ENR)
311	5	Calibration; No ENR data present	W	No ENR Data (ENR)
313	6	Source Uncal	W	
313	6	Source Uncal;adj Start Freq or RBW	W	While using a Tracking Source, you must make sure the Start Frequency is high enough to avoid capturing LO feedthrough in the trace. This depends on both Start Freq and RBW. If you get this message, increase the Start Freq or narrow the RBW.
315	7	Preamp: Accy unspec'd <XX kHz	W	Preamp will function at lower frequencies, but the performance is not specified below XX kHz (XX is model number specific).
317	8	unused	W	
319	9	unused	W	
321	10	unused	W	
323	11	unused	W	
325	12	unused	W	
327	13	unused	W	
329	14	unused	W	

## Condition Errors 401 to 499, Power

This series of errors corresponds to the bits in the `STATUS:QUESTIONABLE:POWER` register. The second column in the table shows the corresponding bit in that register.

An event with the error number shown in the table means the condition has been detected. When the condition is cleared, an event with the error number plus 1000 is generated. These error numbers can be viewed in the Show Errors screen, along with the DETECTED and CLEARED indicators.

For example, error 409 indicates a 50 MHz Oscillator Unleveled condition has been detected, error 1409 indicates that failure has been cleared.

This register is summarized as bit 3 of the `STATUS:QUESTIONABLE` register, as described in the section [“Condition Errors 601 to 699, Error Summaries” on page 133](#).

Err#	Bit in status register	Message	Error or Warning	More Information
401	0	RPP Tripped	W	(not currently in use)
403	1	Source Unleveled	W	
405	2	Source LO Unleveled	E	(not currently in use)
407	3	LO Unleveled	E	(not currently in use)
409	4	unused		
411	5	unused		
413	6	unused		
415	7	unused		
417	8	unused		
419	9	unused		
421	10	unused		
423	11	unused		
425	12	unused		
427	13	unused		
429	14	unused		

## Condition Errors 501 to 599, Frequency

This series of errors corresponds to the bits in the `STATUS:QUESTIONABLE:FREQUENCY` register (s). The second column in the table shows the corresponding bit in that register.

Instrument Messages  
Condition Messages

An event with the error number shown in the table means the condition has been detected. When the condition is cleared, an event with the error number plus 1000 is generated. These error numbers can be viewed in the Show Errors screen, along with the DETECTED and CLEARED indicators.

For example, error 503 indicates a Frequency Reference Unlocked condition has been detected, error 1503 indicates that failure has been cleared.

This register is summarized as bit 5 of the STATUS:QUESTIONABLE register, as described in the section **“Condition Errors 601 to 699, Error Summaries” on page 133.**

Err#	Bit in status register	Message	Error or Warning	More Information
501	0	Source Synth Unlocked	E	
503	1	Frequency Reference Unlocked	E	
505	2	2 <sup>nd</sup> LO Unlocked	E	
507	3	unused		
509	4	LO Unlocked	E	
511	5	unused		
513	6	IF Synthesizer Unlocked	E	
515	7	Calibration Oscillator Unlocked	E	
517	8	unused		
519	9	Demodulation	E	
521	10	Ref missing or out of range	E	
521	10	Ref missing or out of range; External	E	The external frequency reference signal is missing or is not within the proper amplitude range.  In PSA, this error was reported as error 622
521	10	Ref missing or out of range; Pulse	E	The pulse reference signal is missing or is not within the correct amplitude range.
523	11	unused		
525	12	unused		
527	13	unused		
529	14	unused		

## Condition Errors 601 to 699, Error Summaries

This series of errors corresponds to the bits in the `STATUS:QUESTIONABLE` register, read with a `STATUS:QUESTIONABLE?` event query or a `STATUS:QUESTIONABLE:CONDITION?` query.

The second column in the table shows the corresponding bit in the status register. These bits do not have any corresponding error messages, although error numbers have been reserved for them as seen in the `Err#` column; they are status bits only.

The bits in the `STATUS:QUESTIONABLE` register are “summary bits” for registers at a lower level. Note that these summary bits summarize the state and history of the event registers at the lower level. This is true even for bits in the `STATUS:QUESTIONABLE` condition register. This means that:

- The summary bits read by the `STATUS:QUESTIONABLE:CONDITION?` query are true if any event bits are set in any of the `:QUESTIONABLE` sub-registers `:POWER`, `:TEMPERATURE`, `FREQUENCY`, `CALIBRATION` or `:INTEGRITY`.
- The summary bits read by the `STATUS:QUESTIONABLE?` event query are true if any event bit has undergone a false-to-true transition with the `PTRANSITION` filter set, or a true-to-false transition with the `NTRANSITION` filter set, in any of the `:QUESTIONABLE` sub-registers `:POWER`, `:TEMPERATURE`, `FREQUENCY`, `CALIBRATION` or `:INTEGRITY`.

Thus, the summary bits **cannot** be used to determine the current state of a lower level condition bit; only the state and history of the lower level event bits.

Err#	Bit in status register	Message	Error or Warning	More Information
601	0	unused		
603	1	unused		
605	2	unused		
607	3	<b>Power</b>	status bit only	This bit is the summary bit for the <code>STATUS:QUESTIONABLE:POWER</code> sub-register.
609	4	<b>Temperature</b>	status bit only	This bit is the summary bit for the <code>STATUS:QUESTIONABLE:TEMPERATURE</code> sub-register.
611	5	<b>Frequency</b>	status bit only	This bit is the summary bit for the <code>STATUS:QUESTIONABLE:FREQUENCY</code> sub-register.
613	6	unused		
615	7	unused		
617	8	<b>Calibration</b>	status bit only	This bit is the summary bit for the <code>STATUS:QUESTIONABLE:CALIBRATION</code> sub-register.

Err#	Bit in status register	Message	Error or Warning	More Information
619	9	<b>Integrity</b>	status bit only	This bit is the summary bit for the STATUS:QUESTIONABLE:INTEGRITY sub-register.
621	10	unused		
623	11	unused		
625	12	unused		
627	13	unused		
629	14	unused		

### Condition Errors 701 to 799, Operation

This series of errors corresponds to the bits in the STATUS:OPERATION register, which can be read with a STATUS:OPERATION? event query or a STATUS:OPERATION:CONDITION? query.

An event with the error number shown in the table means the condition has been detected. When the condition is cleared, an event with the error number plus 1000 is generated.

For example, error 721 indicates that the DC Coupled condition has been detected; error 1721 indicates that condition has been cleared.

Unless otherwise noted in the **Error or Warning** column below, these are status bits only, with no corresponding error message or number

Err#	Bit in status register	Message	Error or Warning	More Information
701	0	<b>Calibrating</b>	status bit only	
703	1	<b>Settling</b>	status bit only	
705	2	unused		
707	3	<b>Sweeping</b>	status bit only	
709	4	<b>Measuring</b>	status bit only	
711	5	<b>Waiting for Trigger</b>	status bit only	
713	6	<b>Waiting for Arm</b>	status bit only	

Instrument Messages  
Condition Messages

Err#	Bit in status register	Message	Error or Warning	More Information
715	7	unused		
717	8	<b>Paused</b>	status bit only	
719	9	<b>Source Sweeping</b>	status bit only	The "Source Sweeping" bit is used to indicate various conditions, depending on the Mode of operation:  In the List Sequencer mode, it is used to indicate that the sequencer is running  In the EMI Receiver mode, it is used to indicate that scan results are available from the Frequency Scan measurement
721	10	<b>DC Coupled</b>	W	
723	11	unused		
725	12	<b>Source Waiting for Trigger</b>	status bit only	
727	13	unused		
729	14	unused		

### Condition Errors 801 to 899, Temperature

This series of errors corresponds to the bits in the `STATUS:QUESTIONABLE:TEMPERATURE` register. The second column in the table shows the corresponding bit in that register.

An event with the error number shown in the table means the condition has been detected. When the condition is cleared, an event with the error number plus 1000 is generated. These error numbers can be viewed in the Show Errors screen, along with the DETECTED and CLEARED indicators.

For example, error 801 indicates that the Ref Osc Oven Cold condition has been detected; error 1801 indicates that condition has been cleared.

This register is summarized as bit 4 of the `STATUS:QUESTIONABLE` register, as described in the section **"Condition Errors 601 to 699, Error Summaries" on page 133**.

Err#	Bit in status register	Message	Error or Warning	More Information
801	0	<b>Reference Oscillator Oven Cold</b>	W	(not currently in use)

Instrument Messages  
Condition Messages

<b>Err#</b>	<b>Bit in status register</b>	<b>Message</b>	<b>Error or Warning</b>	<b>More Information</b>
803	1	unused		
805	2	unused		
807	3	unused		
809	4	unused		
811	5	unused		
813	6	unused		
815	7	unused		
817	8	unused		
819	9	unused		
821	10	unused		
823	11	unused		
825	12	unused		
827	13	unused		
829	14	unused		



## 4 RF Section Troubleshooting

### What You Will Find in This Chapter

The following information is found in this chapter:

1. Theory of operation of the RF section
2. Isolating the cause of an hardware problem by verifying the functionality of assemblies in the RF section signal path.

#### NOTE

**Each section describes how the assembly works and gives information to help you troubleshoot the assembly. Each description covers the purpose of the assembly, describes the main components, and lists external connections to the assembly.**

---

This following descriptions are found in this chapter:

[RF Section Description on page 138](#)

[Troubleshooting on page 146](#)

[Quick Check to Verify the Low Band Signal Path on page 146](#)

[Troubleshooting a Low Band Problem on page 151](#)

[Quick Check to Verify High Band RF Path #1 on page 174](#)

[Troubleshooting a High Band Problem on page 178](#)

[High Band Preamp \(Option P08, P13, P26\) on page 204](#)

[High Band Mixing Equations on page 204](#)

[Microwave Preselector Bypass \(Option MPB\) on page 205](#)

## RF Section Description

### Purpose

This section covers only those optional frequency ranges listed below for the N9020A, Signal Analyzer.

- Option 503, 3.6 GHz Frequency Range
- Option 508, 8.4 GHz Frequency Range
- Option 513, 13.6 GHz Frequency Range
- Option 526, 26.5 GHz Frequency Range

The RF input signal can be routed through three different front end signal paths. These various paths are switched in and out based on where the signal analyzer center frequency is tuned.

- 1. Low band RF path is used when the input frequency is  $\leq$  3600 MHz**
- 2. High band RF path #1 is used when the input frequency is  $>$  3.6 GHz to 13.6 GHz**
- 3. High band RF path #2 is used when the input frequency is  $>$  13.6 GHz to 26.5 GHz**

The RF section is designed to convert RF input signals to an intermediate frequency (IF) that is present at the RF output of the A13 Front End assembly. This IF depends on installed options and the IF path selected. This chapter will assume the default operation in Spectrum Analyzer mode. Therefore, the IF will be 322.5 MHz.

Table 4-1

IF Path	IF	Mode
10 MHz (standard)	322.5 MHz	Spectrum Analyzer or IQ Analyzer
25 MHz (Option B25)	322.5 MHz	IQ Analyzer
40 MHz (Option B40)	250 MHz	IQ Analyzer

The RF section is comprised of the following major assemblies:

- A9 Input Attenuator A
- A10 Input Attenuator B
- A11 Low Band Switch Assembly
- A12 YTF Preselector
- A14 L.O. Synthesizer Assembly
- A13 RF Front End Assembly
- A15 Front End Control Assembly
- SW1 and SW2 - Option MPB Microwave Preselector Bypass

**NOTE**

**SW1 and SW2 and their associated cables are the microwave preselector bypass hardware. This hardware is present in analyzers containing any or all of the following three options:**

- MPB, Microwave Preselector Bypass
- B40, 40 MHz Analysis Bandwidth
- DP2, Digital Signal Processing & 2 GB Capture Memory

**However, if there is no license for option MPB, the hardware will default to the non-bypassed path (high band microwave signals will be routed through the A12 YTF Preselector). If a license for Option MPB is present, it will be possible to bypass the A12 YTF Preselector.**

---

**1. RF input frequencies < 3600 MHz** route through the low band path. Refer to [Chapter 11, “Block Diagrams”](#) for details.

The RF input signal level can be optimized by either Input Attenuator A or Input Attenuator B. The low band switch is biased in such a way that the signal is routed to the input of the A13 RF Front End assembly. There are (3) different signal paths on the input of the RF Front End assembly that the signal can be routed through depending on installed options and front panel settings.

- Electronic Attenuator path, 0-24 dB (Option EA3)
- Low Band Preamplifier path, 20 dB nominal gain (Option P03)
- Direct to Mixer #1

**NOTE**

The RF input signal can route through the Electronic Attenuator section or the Preamplifier, but not both. All RF input frequencies < 3600 MHz go to Mixer #1.

---

The RF input signal is then mixed with the 1st L.O. from the A14 L.O. Synthesizer assembly in Mixer #1 to a 1st intermediate frequency of 5122.5 MHz. Since the RF input signal is <3600 MHz for low band, this RF input signal is upconverted in Mixer #1 to the 1st I.F. This 1st I.F. signal is then downconverted in Mixer #2 using the 4800 MHz 2nd L.O. generated on the A16 Reference assembly to a 2nd intermediate frequency of 322.5 MHz (5122.5 MHz (1st I.F.) – 4800 MHz (2nd L.O.)). The 2nd I.F. output is at A13J7 on the A13 RF Front End Assembly. This signal path is used for all frequency range options when the RF input frequencies are < 3600 MHz. The control voltages and biasing for these assemblies come from the A15 Front End Control assembly.

**2. RF input frequencies from 3.6 GHz to 13.6 GHz** go through high band path #1. Refer to [Chapter 11, “Block Diagrams”](#) for details.

This signal level can be optimized by either Input Attenuator A or Input Attenuator B. The signal is then routed to the low band switch, which will route the signal to the A12 YTF Preselector.

The signal then routes to the A12 YTF Preselector before going to the A13 RF Front End Assembly. The input switch in the RF Front End Assembly routes the RF input signal to Mixer #2. The RF input signal is then mixed with the 1st L.O. from the A14 L.O. Synthesizer Assembly in Mixer #2 to a 1st intermediate frequency of 322.5 MHz. The 322.5 MHz I.F. output is at A13J7 of the RF Front End Assembly. This is the signal path for Option 508, 8.4 GHz Frequency Range, Option 513, 13.6 GHz Frequency Range, and Option 526, 26.5 GHz Frequency Range (up to 13.6 GHz). The control voltages and biasing for these assemblies come from the A15 Front End Control Assembly.

**3. RF input frequencies from 13.6 GHz to 26.5 GHz** go through high band path #2. Refer to **Chapter 11, “Block Diagrams”** for details.

This signal level can be optimized by either Input Attenuator A or Input Attenuator B. The signal is then routed to the low band switch, which will route the signal to the A12 YTF Preselector.

The low band switch is biased by the A15 Front End Control Assembly. The signal then routes to the A12 YTF Preselector before going to the A13 RF Front End Assembly. The input switch in the RF Front End Assembly routes the RF input signal to Mixer #3. The RF input signal is then mixed with the 1st L.O. from the A14 L.O. Synthesizer Assembly in Mixer #3 to a 1st intermediate frequency of 322.5 MHz. The LO is doubled at tuned frequencies above 17 GHz. The 322.5 MHz I.F. output is at A13J7 of the RF Front End Assembly. This is the signal path for Option 526, 26.5 GHz Frequency Range (for frequencies  $\geq 13.6$  GHz). The control voltages and biasing for these assemblies come from the A15 Front End Control Assembly.

## RF Section Theory of Operation

### A9 Input Attenuator A

This assembly has two 2 dB attenuator sections, a DC block and a cal signal input port. With the DC block switched in (AC coupled mode), the low end minimum frequency range increases from 20 Hz to 10 MHz due to capacitive effects.

### A10 Input Attenuator B

This assembly has a total of 66 dB of attenuation to control the RF level going to the mixer assemblies in the A13 RF Front End Assembly. There is a 6 dB, 10 dB, 20 dB, and 30 dB section in the A10 assembly. Total input attenuation with the A9 and the A10 combined is 70 dB in 2 dB steps.

### A11 Low Band Switch

This assembly operates across the entire frequency range of the analyzer. The switch has 3 main functions:

- Switch RF input frequencies from 20 Hz to 3.59 GHz RF Output to A13 RF Front End Assembly.
- Switch RF input frequencies from 3.6 GHz to 26.5 GHz Microwave RF Output to A12, YTF Preselector.
- Optional high band preamplifier, which has a typical gain of 30 dB and a noise figure from 9-12 dB up to 18 GHz.

### A12 YTF Preselector

The YTF Preselector is used for input frequencies greater than 3.6 GHz. Signals less than 3.6 GHz bypass the YTF assembly and are routed directly to the A13 RF Front End Assembly. The YTF Preselector is a YIG tunable bandpass filter whose main purpose is to filter out unwanted spurious or image response signals. When the YTF is calibrated, the tunable bandpass will track the RF input signal. The YTF Preselector has a 3 dB bandwidth greater than 40 MHz and an insertion loss of ~ 6.5 dB.

The preselector requires centering for optimum amplitude accuracy. The Auto Align routine will perform a rough centering during the preselector two-point tuning algorithm. However, when troubleshooting, press **Amplitude, Preselector Center** to manually center the preselector.

The YTF Preselector is not present in most analyzers with Option 503, 3.6 GHz frequency range.

### A14 L.O. Synthesizer Assembly

The L.O. Synthesizer Assembly provides the 1st L.O. power that is required for the A13 RF Front End Assembly. The 1st L.O. has a frequency range from 3.80 to 8.70 GHz. Harmonics of the 1st L.O. are used to down convert RF input signals up to 26.5 GHz. Table 4-1 provides some examples of how the L.O. is multiplied for the given center frequency of the analyzer and which high band mixer is being used on the A13 RF Front End assembly. The output power is +13 to +18 dBm. In order to maximize the conversion efficiency, sufficient L.O. power must be supplied to the mixer in the A13 RF Front End Assembly from this assembly.

Table 4-2

#### X-Series Signal Analyzers

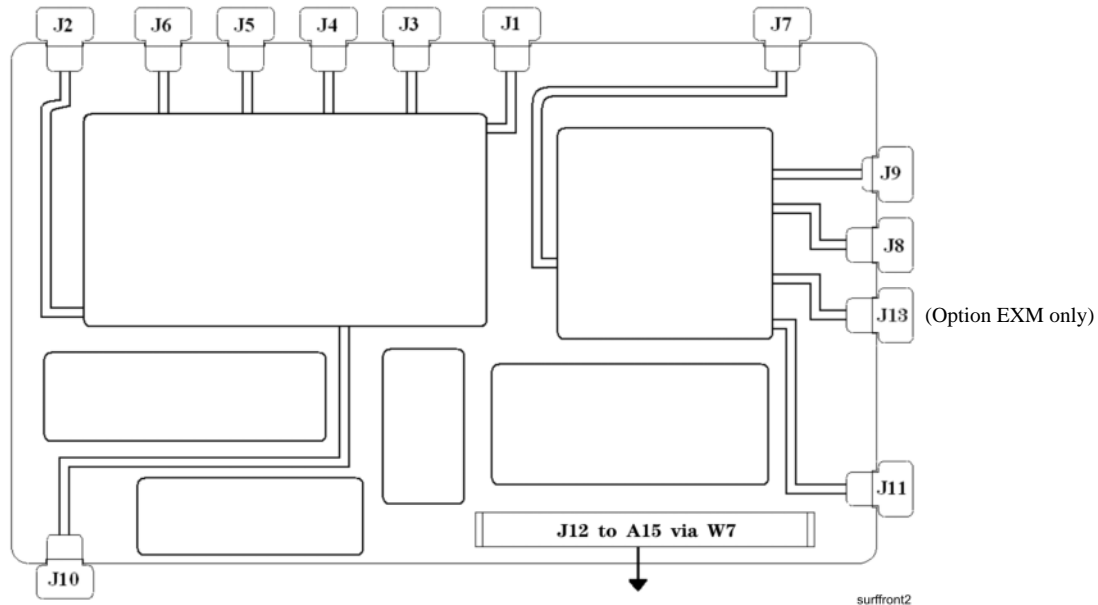
Analyzer Center Frequency <sup>a</sup>	1st L.O. @ A14J740	Desired 1st L.O. Harmonic @ Mixer 2 or 3
5 GHz	5.3225 GHz	5.3225 GHz <sup>b</sup>
10 GHz	5.16125 GHz	10.3225 GHz <sup>b</sup>
13.5 GHz	6.91125 GHz	13.8225 GHz <sup>b</sup>
14.5 GHz	7.41125 GHz	14.8225 GHz <sup>c</sup>
22 GHz	5.5806250 GHz	22.3225 GHz <sup>c</sup>

- a. Set span to Zero Span to measure 1st L.O.
- b. A13 Mixer 2 (refer to **Chapter 11, "Block Diagrams."**)
- c. A13 Mixer 3 (refer to **Chapter 11, "Block Diagrams."**)

### A13 RF Front End Assembly

This assembly is a self-contained microcircuit that is repaired at the assembly level. See [Figure 4-1](#).

Figure 4-1 A13 RF Front End Assembly View from Front Panel



This assembly contains the following circuits:

- Input Low-pass filter (RF input signals < 3.6 GHz)
- Low Band Limiter
- Optional Electronic Attenuator (0-24 dB attenuation control)
- Optional Low Band Preamplifier
- RF Mixer #1 (RF input signals < 3.6 GHz)
- 1st L.O. Sub-system (3.8 GHz to 8.7 GHz)
- 1st I.F. Amplifier (5122.5 MHz)
- I.F. Band pass filter (5122.5 MHz)
- I.F. Low-pass filter (5122.5 MHz)
- Mixer #2 (RF input signals 3.6 GHz to 13.599 GHz)
- Microwave Input Amplifier
- Mixer #3 (RF input signals 13.6 GHz to 26.5 GHz)
- 2nd I.F. Amplifier (322.5 MHz)
- Microwave L.O. Sub-system (3.8 GHz to 8.7 GHz)
- L.O. Doubler



- External Mixing Diplexer (units with Option EXM only)

Table 4-3 A13 RF Front End Signals

Signal Name	Description	From	To
RF Input	20 Hz to 3.59 GHz RF Input	A11J2, Low Band Switch	A13J2
Microwave Input	3.6 GHz to 26.5 GHz U-wave RF Input	YTF Output or SW1	A13J9
E-cal Input	Cal Signal Port	A16J705, Ref. Bd	A13J6
1st L.O. Input	3.8225 to 8.7225 GHz 1st L.O.	A14J40, Synth. Bd	A13J4
2nd L.O. Input	4.8 GHz 2nd L.O.	A16J702, Ref Bd	A13J1
I.F. Output	322.5 MHz I.F. Signal	A13J7	A2J100, AIF or A15J902, EFEC
To Band Pass Filter	Filter Port, 1st I.F. Amplifier Output	A13J10	5.1225 GHz Cavity Input
From Band Pass Filter	Filter Port, 2nd Mixer Input	5.1225 GHz Cavity Output	A13J11

### Front End Control Assembly

Provides the correct biasing and switch control logic to the following RF assemblies:

- Input Attenuator A
- Input Attenuator B
- Low Band Switch
- YTF Preselector (Input signals > 3.6 GHz)
- RF Front End Assembly
- (Optional) High Band Preamplifier
- (Optional) Low Band Preamplifier
- (Optional) Electronic Attenuator (0-24 dB)
- (Optional) Microwave Preselector Bypass

**NOTE**

Refer to **Chapter 5, “Front End Control Troubleshooting.”** for detailed descriptions & troubleshooting procedures

## Troubleshooting

### Quick Check to Verify the Low Band Signal Path

The analyzer has an internal 50 MHz amplitude reference signal that is used to verify the low band path. Refer to [Chapter 11, “Block Diagrams”](#) for details.

Equipment needed:

Functioning Spectrum Analyzer

DVM

Cables & Connectors

**NOTE** To perform the following checks, it will be necessary to remove the outer cover and the top brace. See [Chapter 14](#) for removal procedures.

---

Turn the analyzer on and allow it to complete its full boot up process to Spectrum Analyzer mode. Use the internal 50 MHz, -25 dBm calibrator signal as a reference for troubleshooting by pressing **Mode Preset, Input/Output, RF Calibrator, 50 MHz** on the analyzer. Now press **FREQ (Channel), 50 MHz, SPAN (X Scale), 1 MHz, Peak Search**. The 50 MHz reference signal should measure 50 MHz @ -25 dBm  $\pm$  2 dB on the analyzer display. If the power level is within tolerance, the low band path is functioning correctly at 50 MHz. To verify the high band path go to [“Quick Check to Verify High Band RF Path #1” on page 174](#).

If the power level is not within tolerance, press **SPAN (X Scale), Zero Span, AMPTD (Y Scale), Attenuation, 10 dB**.

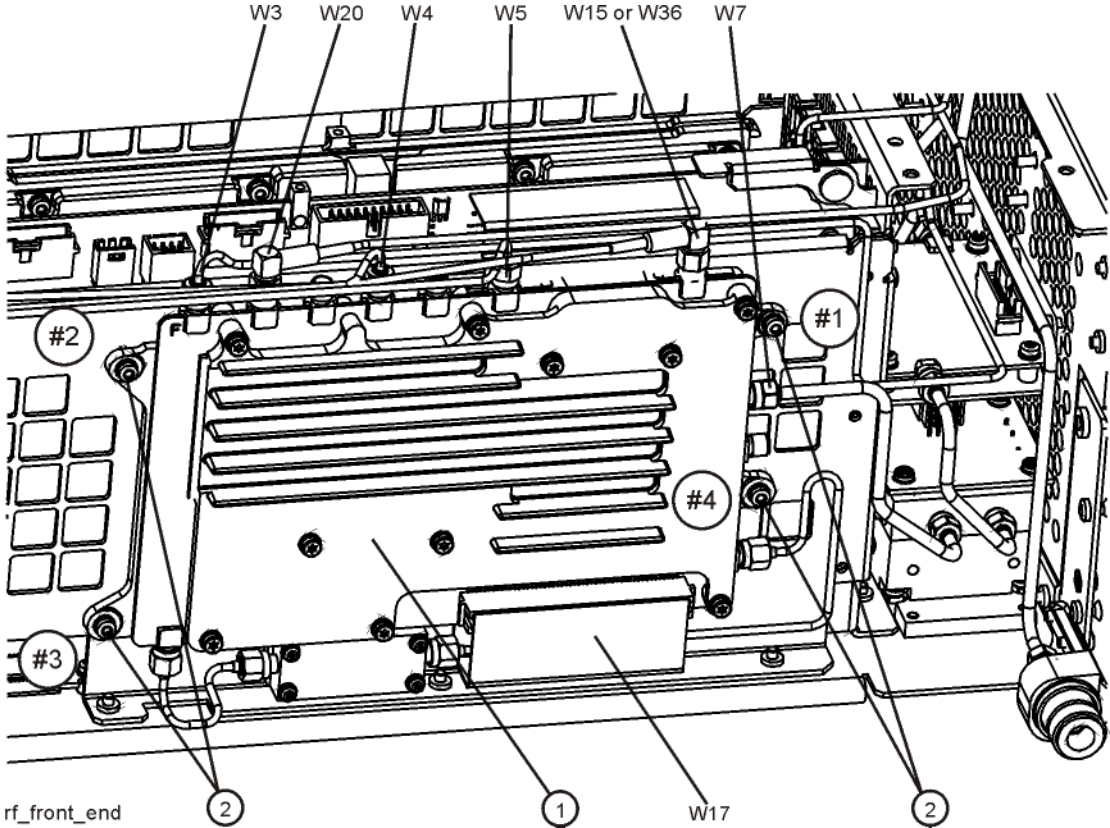
**IMPORTANT** Turn off auto align by pressing **System, Alignments, Auto Align, Off**.

---

Disconnect the W15 or W36 cable from A13J7 on the RF Front End Assembly  
**(1)** 322.5 MHz output. See **Figure 4-2**.

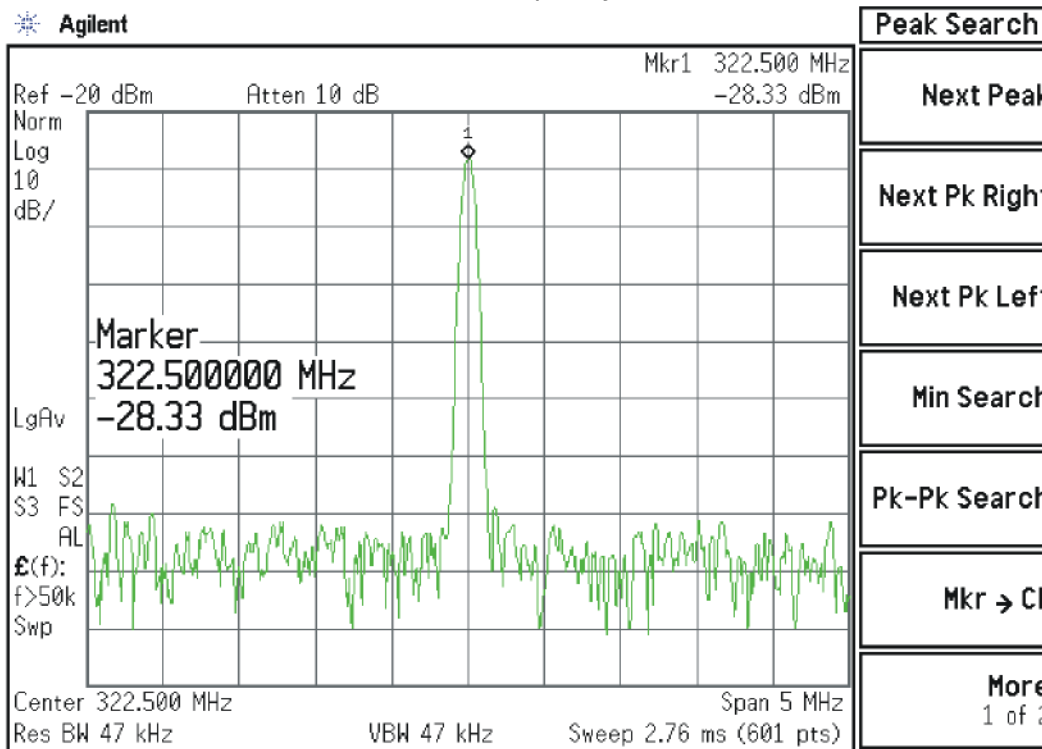
Figure 4-2

W15 or W36 Location



Connect A13J7 output to a functioning spectrum analyzer and verify the 322.5 MHz intermediate frequency is measuring  $-28.5 \pm 3$  dB using the same analyzer settings as in **Figure 4-3**.

Figure 4-3 322.5 MHz Intermediate Frequency



If this power level is correct the RF assembly from the A9 50 MHz Reference signal input port to A13J7, 322.5 MHz I.F. Output is operating correctly using a 50 MHz input calibrator signal. Reconnect the W15 or W36 cable to A13J7.

**NOTE** Flatness issues or power level problems at other input frequencies below 3600 MHz may exist. This type of problem can be diagnosed using the suspect RF input frequency.

If this power level is incorrect, the following assemblies need to be verified in the order listed using the 50 MHz internal calibrator signal. Be sure the 50 MHz calibrator is turned on **Input/Output, RF Calibrator, 50 MHz** when verifying the performance.

1. A16 Reference Assembly
2. A14 L.O. Synthesizer
3. A15 Front End Control Assembly
4. A9 Input Attenuator A
5. A10 Input Attenuator B
6. A11 Low Band Switch
7. A12 YTF Preselector
8. A13 RF Front End Assembly

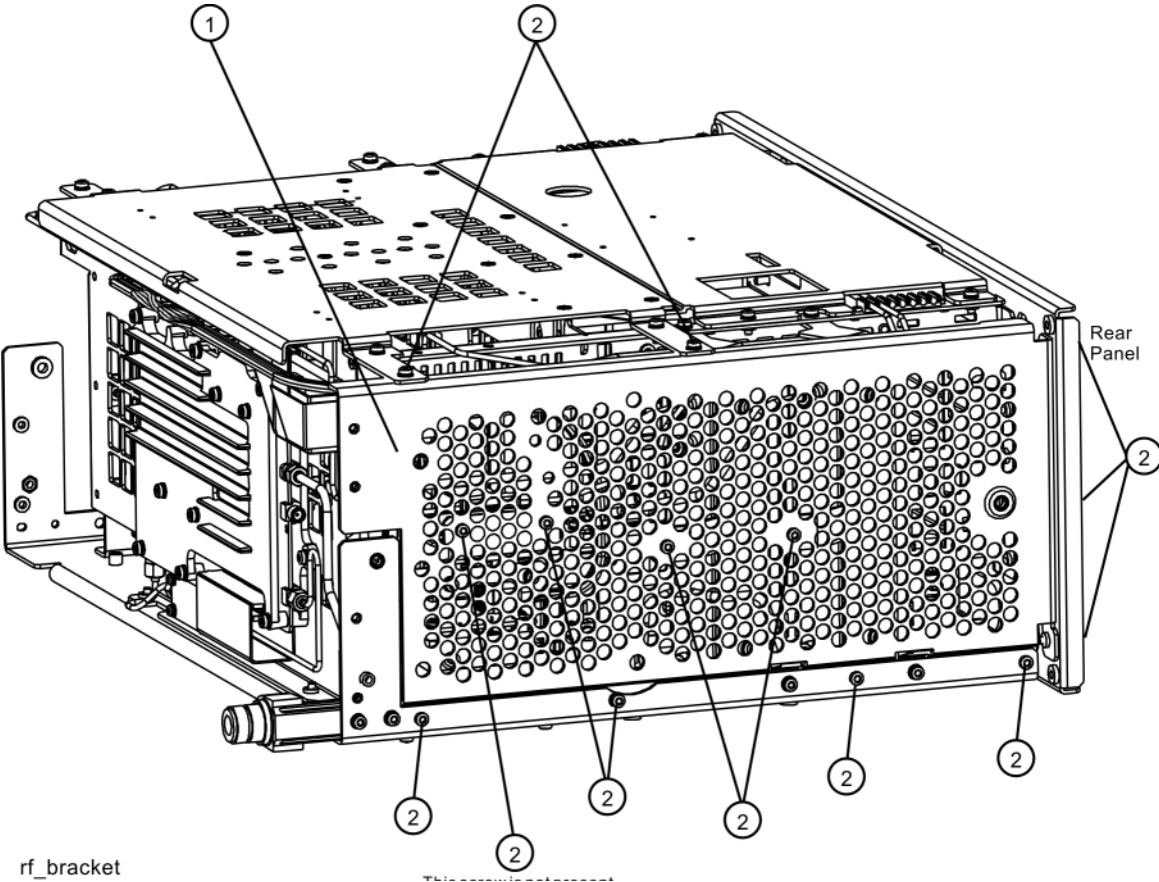
**NOTE**

In order to gain access to the front end components, remove the side chassis (1) by removing the 10 screws (2). Refer to [Figure 4-4](#).

---

Figure 4-4

Remove the Side Chassis



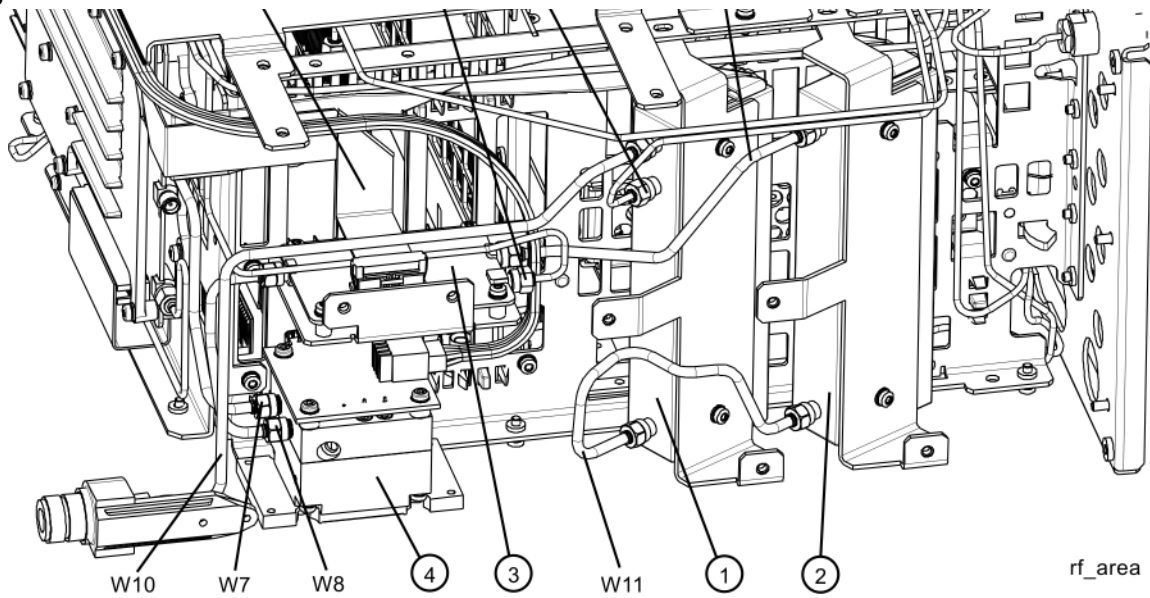
## Troubleshooting a Low Band Problem

### 1. Reference Assembly Verification

Remove cable W19 from A9 Input Attenuator A **(1)** and measure the 50 MHz calibrator signal on the cable end with a functioning Spectrum Analyzer. Refer to **Figure 4-5**.

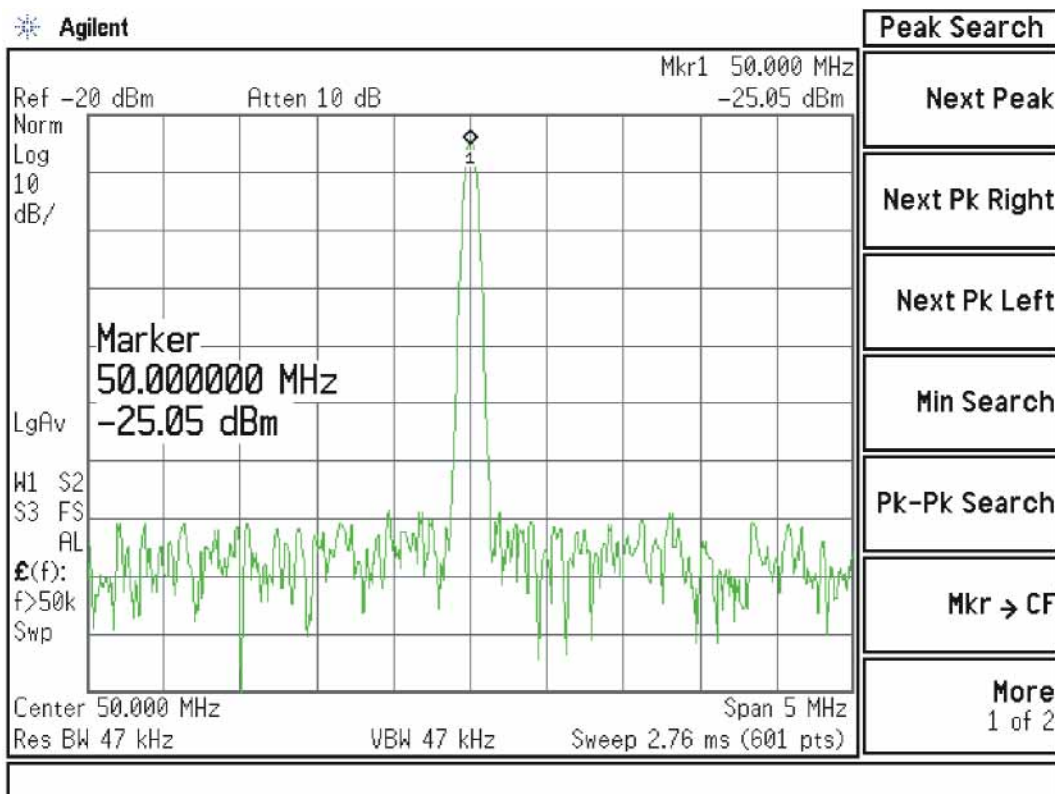
Figure 4-5

W19 Location



If the Reference assembly calibrator is functioning properly the 50 MHz calibrator signal will measure 50 MHz at  $-25 \text{ dBm} \pm 3 \text{ dB}$ . See **Figure 4-6**. If this level is incorrect, the Reference assembly is most likely defective. Reconnect W19 at A9 Input Attenuator A.

Figure 4-6 50 MHz Calibrator Signal





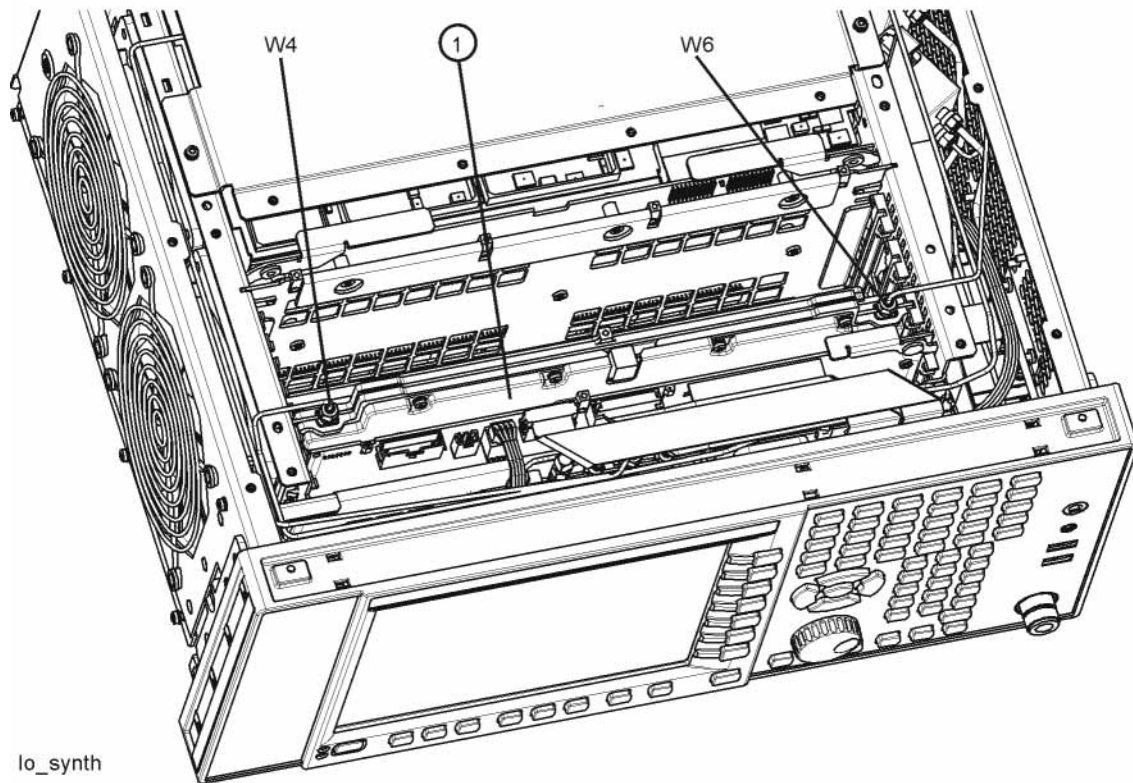
## 2. L.O. Synthesizer Assembly Verification

Press the following keys on the analyzer:

**FREQ (Channel), 1 GHz**  
**SPAN (X Scale)**  
**Zero Span**

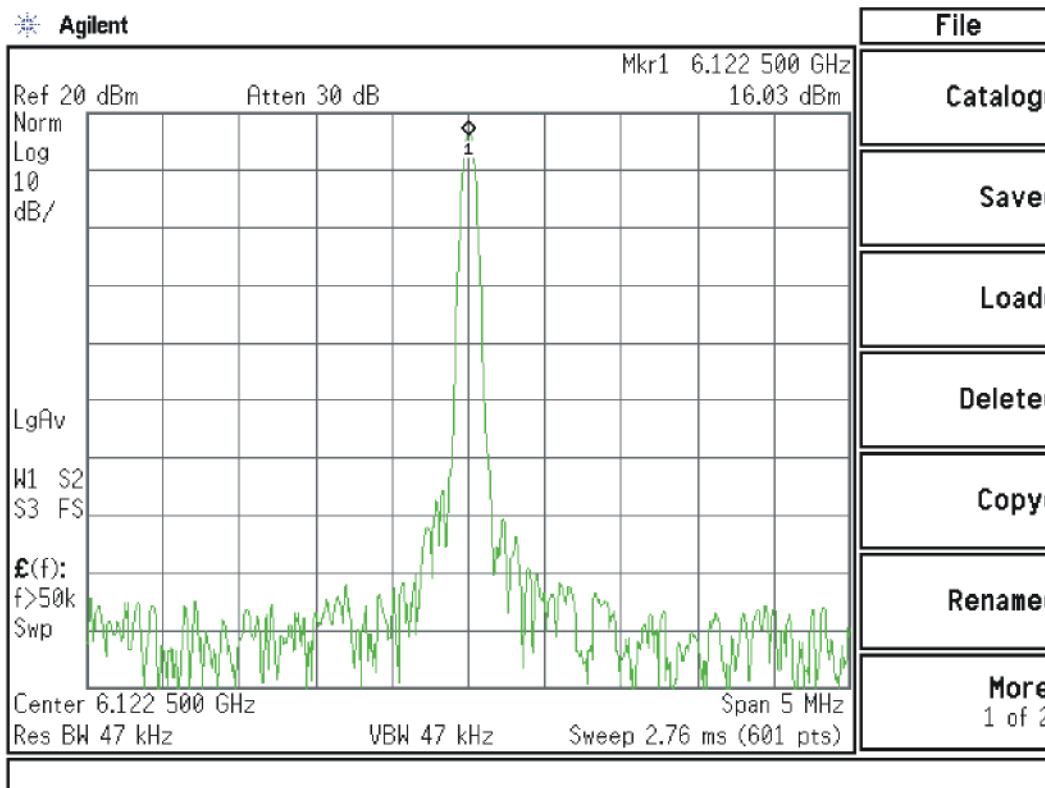
Refer to **Figure 4-7**. Disconnect cable W4 at A14J740 of the L.O. Synthesizer Assembly **(1)**.

Figure 4-7 W4 and W6 Location



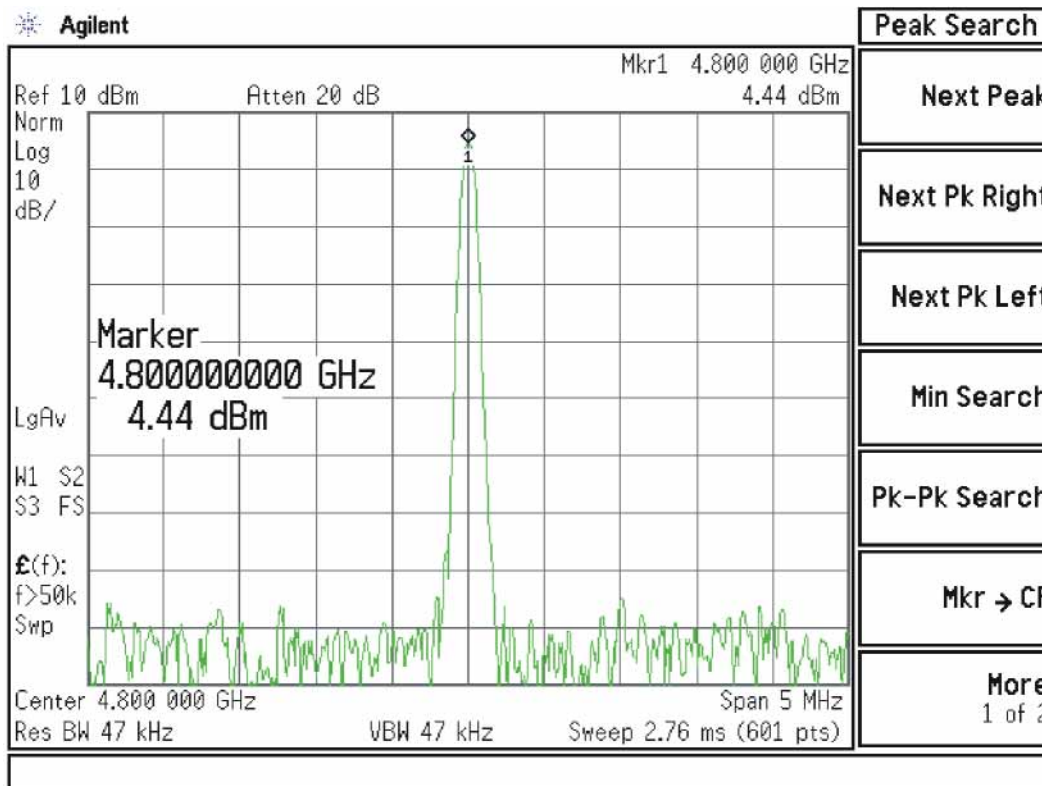
Connect the functioning Spectrum Analyzer and appropriate high frequency cable and connector to A14J740. Adjust the functioning Spectrum Analyzer to measure a signal at 6122.5 MHz at +16 dBm  $\pm$  4 dB as seen in **Figure 4-8**.

Figure 4-8 Measure 1st L.O.



If this power level is incorrect remove W6 at A14J200. Refer to [Figure 4-7](#).  
Adjust the functioning spectrum analyzer to measure a signal at 4.800 GHz at  
 $+4.5 \text{ dBm} \pm 2 \text{ dB}$ . See [Figure 4-9](#).

Figure 4-9 4.800 GHz Signal at A14J200



If this power level is incorrect, the most probable cause is the A16 Reference Assembly. If this level is correct and yet the signal previously measured at A14J740 is incorrect, the most probable cause is the A14 L.O. Synthesizer Assembly. Reconnect W4 cable to A14J740. Reconnect W6 cable to A14J200.

### 3. Front End Control Assembly Verification

Verifying the Front End Control Assembly requires the RF Front End Troubleshooting board E4410-60115 or kit number N9020-60005. The kit includes the troubleshooting board and associated interconnect cables. The troubleshooting board and cables will help verify the control logic from this assembly to Input Attenuator A, Input Attenuator B, Low Band Switch, YTF Preselector, (Optional) Low Band Preamplifier, (Optional) High Band Preamplifier, (Optional) Electronic Attenuator and the RF Front End Assembly. The control logic should be verified going to each assembly while the Front End Troubleshooting board is connected.

**NOTE**

Even though the YTF Preselector is not used in low band (input frequencies < 3.59 GHz), it is easy to test the switch control logic with the RF Front End Troubleshooting board installed in case there is a high band problem. The Low Band Preamplifier (Option P03), High Band Preamplifier, and Electronic Attenuator (Option EA3) logic should be tested if these options are installed in the analyzer.

- 
- Turn off the instrument.
  - Connect the E4410-60115 Front End Troubleshooting board to the A15 Front End Control Assembly as shown in [Figure 4-10](#) and [Figure 4-11](#).

Figure 4-10 RF Front End Troubleshooting Board

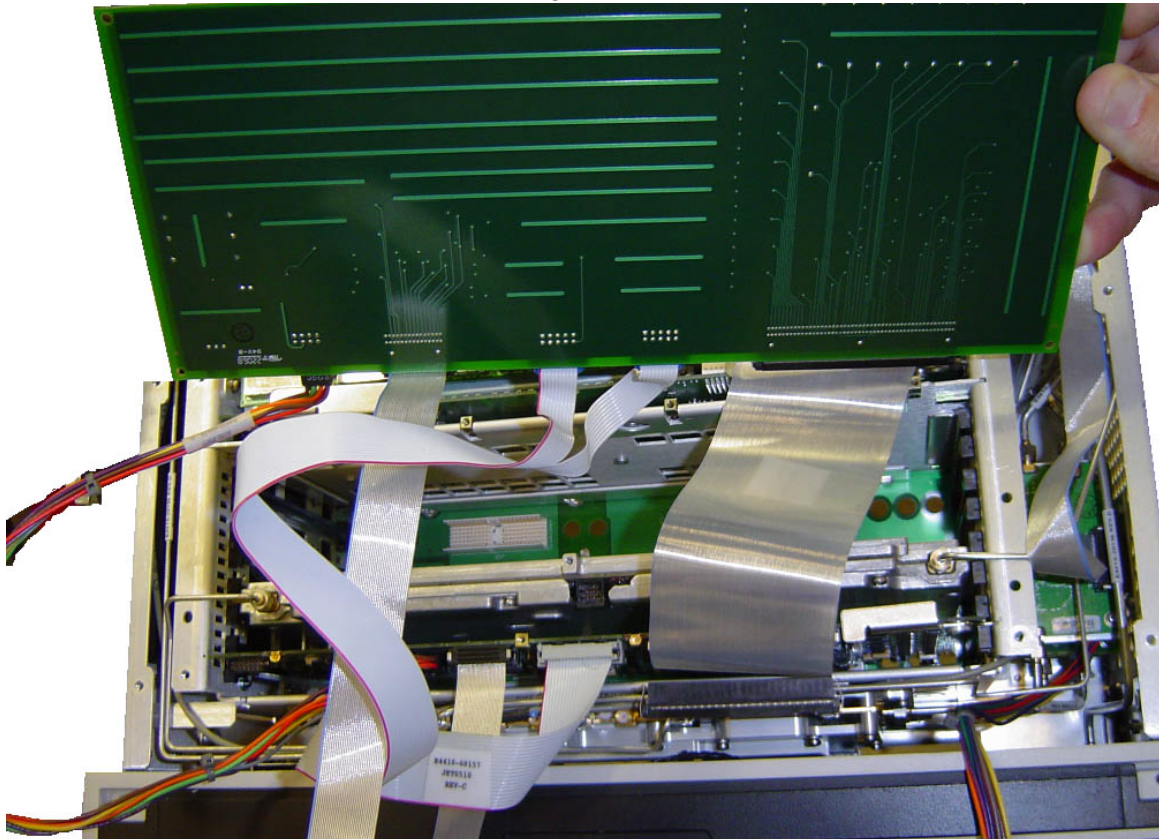
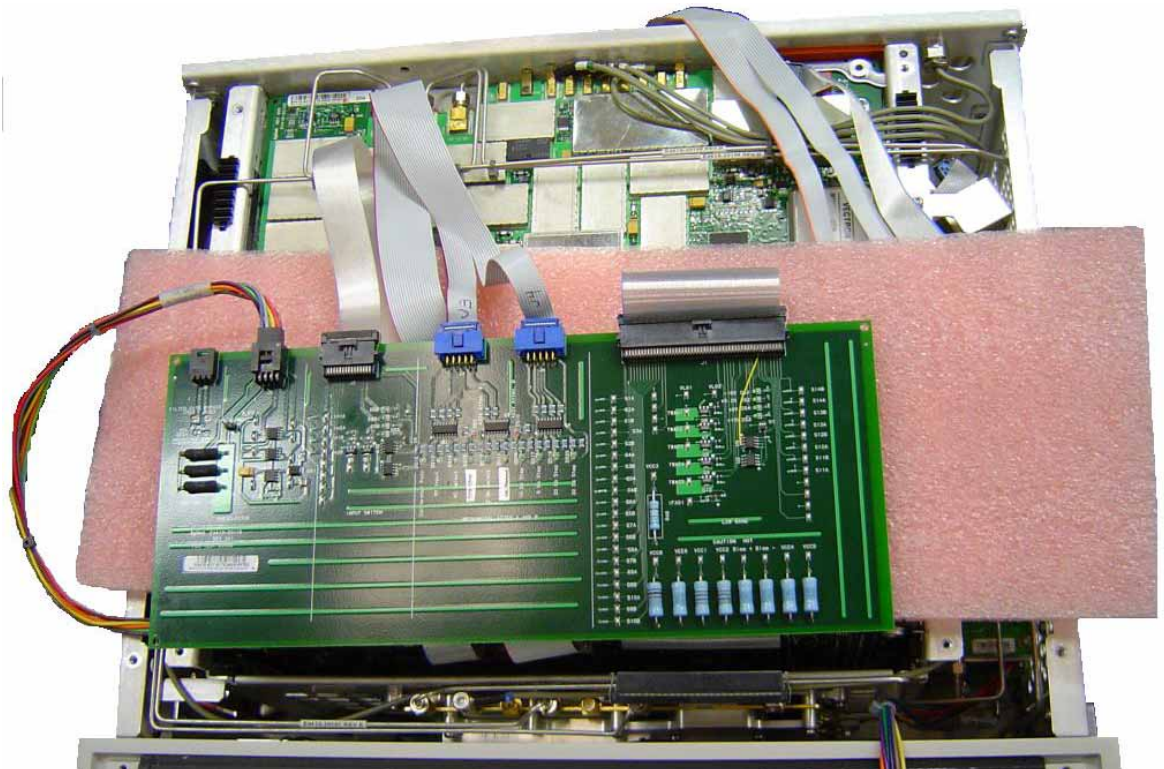


Figure 4-11 RF Front End Troubleshooting Board



- Turn the instrument on and allow it to complete its full boot up process to the signal analyzer application.
- Turn Auto Align off by pressing **System, Alignments, Auto Align, Off** on the analyzer.

**CAUTION**

Resistors on the board can get very hot.

---

- Verify all power supply LED's on the Front End Troubleshooting board are turned on. Under the J2 connector, the supplies are +15 VDC, +9 VDC, +5.2 VDC, and –15 VDC. Under the J1 connector, the supplies are +15 VDC, –15 VDC, +9 VDC and +5.2 VDC. Verify both input attenuator power supplies. DS9 under J3 should be on if the +25V supply is up for Attenuator A. DS10 under J4 should be on if the +25V supply is up for Attenuator B. If any of the power supply LED's are not turned on, see **Chapter 2, “Boot Up and Initialization Troubleshooting”**.

**NOTE**

The analyzer will display an error dialogue box when booting up. Simply click “OK” so the instrument can complete its boot process. Additionally, the analyzer noise floor will be near the top of the display since the RF assemblies are not powered up. This is normal with the Front End Troubleshooting board connected to the A15 Front End Driver Assembly

---

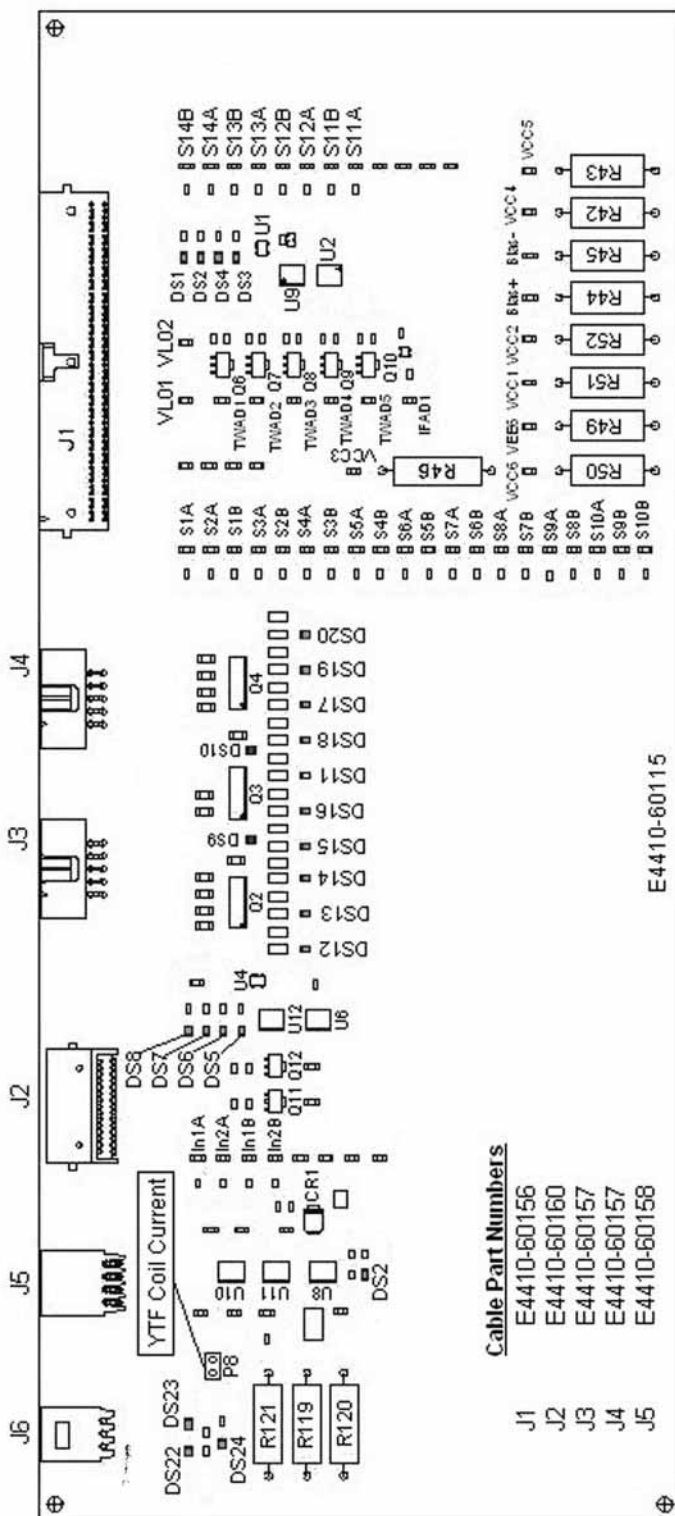
#### 4. Input Attenuator A Control Logic Verification

- Press **AMPTD, Attenuation 0 dB**

All the attenuation LED's on the Front End Troubleshooting board should be off except for DS9 and DS10, +25V supply for Attenuator A and Attenuator B. Refer to **Figure 4-12**.

Figure 4-12

Front End Troubleshooting Board Attenuation LEDs



When the input attenuation is changed from 0 dB to 2 dB, the 2 dB Step LED DS15 should illuminate. When the input attenuation is changed from 2 dB to 4 dB, DS15 and DS16 should be illuminated as per [Table 4-4](#).

Table 4-4 Attenuator A Logic

Attenuator Setting (dB)	DS15 2 dB Step LED	DS16 2 dB Step LED
0		
2	X	
4	X	X

The analyzer default setting for RF Coupling is AC mode. Verify the AC Select LED DS14 is illuminated at this time. Set **Input/Output, RF Input, RF Coupling** to DC. DS14 turns off, DS11 DC Select yellow LED should illuminate. Switch the RF Coupling back to AC. If the LED's illuminate correctly, the switch control logic to Input Attenuator A from the A15 Front End Control Assembly is correct. If the LED's are not illuminating as expected, the most probable cause is the A15 Front End Control Assembly.



### 5. Input Attenuator B Control Logic Verification

Press **AMPTD, Attenuation 6 dB** and verify the 6 dB Step LED DS17 is illuminated. Enter the input attenuation settings found in **Table 4-5** and verify the proper LED's illuminate on the Front End Troubleshooting board according to **Table 4-5**.

Table 4-5 Attenuator B Logic

Attenuator Setting (dB)	DS20 30 dB Step LED	DS19 20 dB Step LED	DS18 10 dB Step LED	DS17 6 dB Step LED
10			X	
16			X	X
20		X		
30	X			
40	X		X	
50	X	X		
60	X	X	X	
66	X	X	X	X

Set the input attenuator back to 10 dB by pressing **AMPTD, Attenuation, 10 dB** on the analyzer. If the LED's illuminate correctly, the switch control logic for the input attenuators from the A15 Front End Control Assembly is correct. If the LED's are not illuminating as expected, the most probable cause is the A15 Front End Control Assembly.

## 6. Low Band Switch Control Logic Verification

Press **Mode Preset** on the analyzer. Press **FREQ, 50 MHz, SPAN, 2 MHz** on the analyzer. Connect the DVM positive lead to one of the In1A test points, and the negative lead to the bottom of R46 (blue resistor near the bottom) on the Front End Troubleshooting board. Verify the voltages in [Table 4-6](#).

Table 4-6

In1A	-9.85
In2A	-9.85
In1B	+9.75
In2B	+9.75

Press **Freq 5 GHz** on the analyzer. Verify the voltages in [Table 4-7](#).

Table 4-7

In1A	+9.72
In2A	-9.84
In1B	-9.84
In2B	+9.72

If the voltages are not correct, the most probable cause is the A15 Front End Control Assembly.

## 7. YTF Preselector Control Logic Verification (All except Option 503)

### NOTE

In order to properly measure the preselector tune output from the A15 Front End Control Assembly, the following items are required:

- E9637A Banana plug to BNC (f) adapter
- E9632A BNC (M) to SMA (f)
- 8120-1460 Small coaxial cable SMA (m) to mmcx (m)

---

Connect the mmcx end of the cable to A15J300, preselector tune output at the upper left corner of A15 Front End Control Assembly.

Press **Single** on the analyzer. Verify the voltages in **Table 4-8** as the center frequency of the analyzer is changed.

Table 4-8

YTF Tune Voltages

Center Frequency (GHz)	~ Tune Voltage (VDC)	Tolerance (VDC)
5.0	1.6	±0.5
10 <sup>a</sup>	3.228	±1.0
15 <sup>b</sup>	4.85	±1.0
20 <sup>b</sup>	6.5	±1.0
26 <sup>b</sup>	8.45	±1.0

a. Options 513 and 526

b. Option 526

### NOTE

Tolerances can be used as a guideline. The true test is whether or not the analyzer will function and meet published specification.

---

If any of the preselector tune voltages do not match the levels shown in **Table 4-8**, the most probable causes are a misaligned YTF or the A15 Front End Control Assembly. Perform the YTF characterization (press **System, Alignments, More, Advanced, Characterize Preselector**).

To further test the YTF control current, select Amps on the DVM and place the positive lead of the DVM on one of the YTF Coil Current P8 pins and the other DVM lead to the other Coil Current pin.

**NOTE** In order to measure the control current correctly, press **Single** on the analyzer in between each measurement.

---

If any of the preselector control currents do not match the levels shown in **Table 4-9**, the most probable causes are a misaligned YTF or the A15 Front End Control Assembly. Perform the YTF characterization (press **System, Alignments, More, Advanced, Characterize Preselector**) and re-check the control current at various center frequencies.

Table 4-9 YTF Tune Current

Center Frequency (GHz)	Control Current (mA)	Tolerance (mA)
5.0	106	±20
10 <sup>a</sup>	215	±25
15 <sup>b</sup>	324	±30
20 <sup>b</sup>	430	±40
26 <sup>b</sup>	560	±50

- a. Options 513 and 526
- b. Option 526

**NOTE** Tolerances should be used as a guideline. The true test is whether or not the analyzer will function and meet published specification.

---

## 8. Front End Assembly Control Logic Verification

Since the RF Front End Troubleshooting board is connected, now is a good time to test out the remaining control circuits from the A15 Front End Control Assembly.

Table 4-10 Front End Control Logic

Test Point	Description	Instrument Settings	Voltage (VDC)	Tolerance (VDC)
S2A	Sets switch for Low Band/preamp path	CF 50 MHz preamp on	+9.67	±0.5
S2B	Sets switch for Low Band/preamp path	CF 50 MHz preamp on	+9.83	±0.5
S3A	Sets E-atten to 5 dB preamps off	E-atten = 5 dB	+9.67	±0.5
S3B	Sets E-atten to 5 dB preamps off	E-atten = 5 dB	+9.83	±0.5
S4A	Sets E-atten to 10 dB preamps off	E-atten = 10 dB	+9.67	±0.5
S4B	Sets E-atten to 10 dB preamps off	E-atten = 10 dB	+9.83	±0.5
S5A	Sets E-atten to 2 dB preamps off	E-atten = 2 dB	+9.67	±0.5
S5B	Sets E-atten to 2 dB preamps off	E-atten = 2 dB	+9.83	±0.5
S6A	Sets E-atten to 1 dB preamps off	E-atten = 1 dB	+9.67	±0.5
S6B	Sets E-atten to 1 dB preamps off	E-atten = 1 dB	+9.83	±0.5
S7A	Sets E-atten to 2 dB preamps off	E-atten = 2 dB	+9.67	±0.5
S7B	Sets E-atten to 2 dB preamps off	E-atten = 2 dB	+9.83	±0.5
S8A	Sets E-atten to 20 dB preamps off	E-atten = 20 dB	+9.67	±0.5
S8B	Sets E-atten to 20 dB preamps off	E-atten = 20 dB	+9.83	±0.5
S9A	Controls in & out to low band preamps off	E-atten = off	+9.83	±0.5
S9B	Controls in & out to low band preamps off	E-atten = off	+9.67	±0.5
S11A	Sets path for 1st or 2nd L.O.	CF 1 GHz	+9.67	±0.5
S11B	Sets path for 1st or 2nd L.O.	CF 1 GHz	+9.83	±0.5
S12A	Sets path for L.O. normal or x2 for band 4	CF 1 GHz	+9.83	±0.5
S12B	Sets path for L.O. normal or x2 for band 4	CF 1 GHz	+9.67	±0.5
S13A	Sets path for L.O. to either of the high band mixers and L.O. output	CF 5 GHz CF 20 GHz	-9.67 +9.67	±0.5
S13B	Sets path for L.O. to either of the high band mixers and L.O. output	CF 5 GHz CF 20 GHz	+9.83 -9.83	±0.5

Table 4-10 Front End Control Logic

Test Point	Description	Instrument Settings	Voltage (VDC)	Tolerance (VDC)
S14A	Sets path to either band 1 & 2 mixer or band 3 & 4 mixer	CF 5 GHz CF 20 GHz	-9.83 +9.83	±0.5
S14B	Sets path to either band 1 & 2 mixer or band 3 & 4 mixer	CF 5 GHz CF 20 GHz	+9.67 -9.67	±0.5
VCC1	Voltage always on		4.8	±0.5
VCC2	Voltage always on		4.8	±0.5
VCC3	Voltage always on		7.85	±0.5
VCC4	Voltage always on		5.0	±0.5
VCC5	Voltage always on		5.0	±0.5
TWAD1	Amplifier bias to A13 RF Front End Assembly		6.0	±0.5
TWAD2	Amplifier bias to A13 RF Front End Assembly		6.0	±0.5
TWAD3	Amplifier bias to A13 RF Front End Assembly		6.0	±0.5
TWAD4	Amplifier bias to A13 RF Front End Assembly		6.0	±0.5
TWAD5	Amplifier bias to A13 RF Front End Assembly		6.0	±0.5

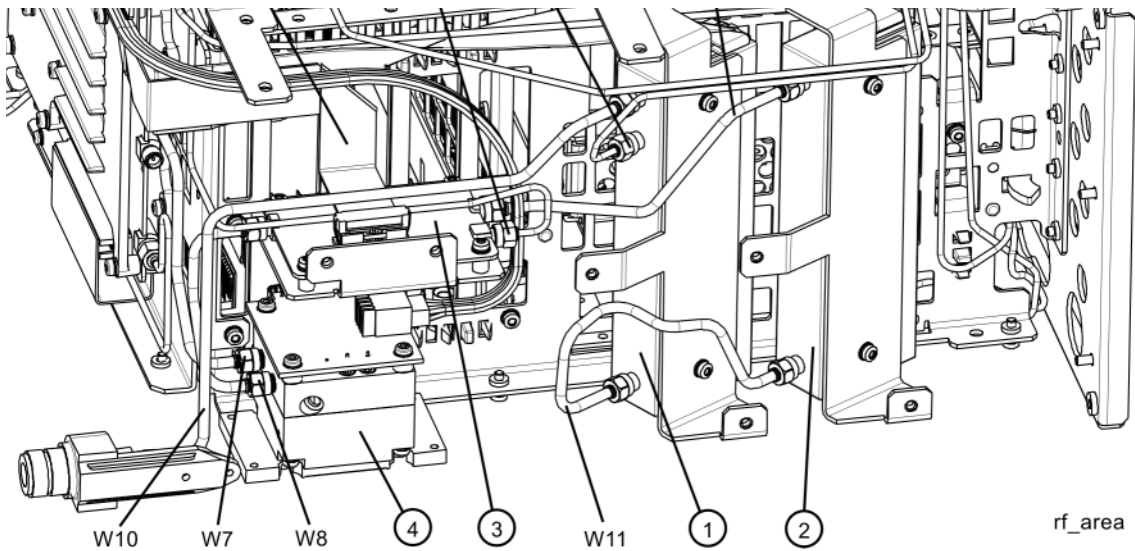
**NOTE** Tolerances should be used as a guideline.

If any of the voltages measured do not match the levels shown in **Table 4-10**, the most probable cause is the A15 Front End Control Assembly. Once the switch control logic has been verified, turn off the instrument, disconnect the RF Front End Troubleshooting board cables, and reconnect the analyzer cables to the A15 Front End Control Assembly. Turn the instrument on and allow it to complete its full boot up process to Spectrum Analyzer mode.

### Input Attenuator A Power Level Verification

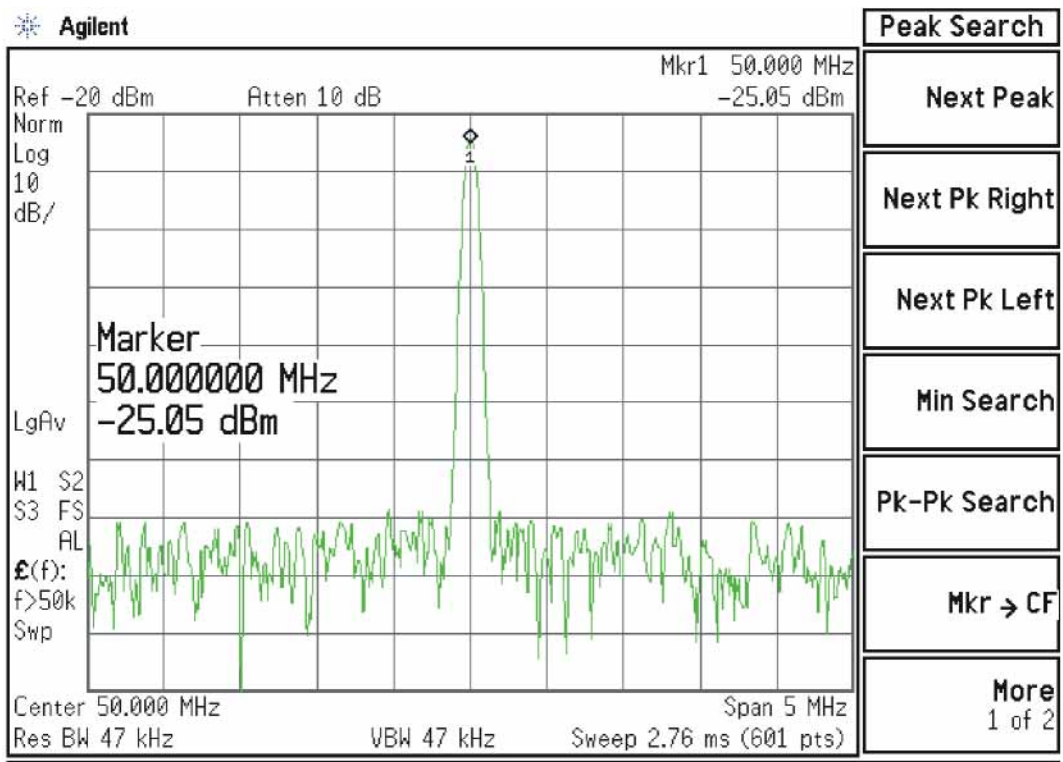
Press **Mode Preset, Input/Output, RF Calibrator, 50 MHz, AMPTD, Attenuation, 0 dB** on the analyzer. Refer to **Figure 4-13**, remove cable W11 from A9 **(1)** Output. Measure the 50 MHz calibrator signal on the output of the attenuator using a functioning Spectrum Analyzer.

Figure 4-13 Cable W11



The level should be  $-25 \text{ dBm} \pm 2 \text{ dB}$  as shown in [Figure 4-14](#).

Figure 4-14 50 MHz Calibrator Signal on Output of Attenuator A



Press **Mech Atten** and enter 2 dB. The 50 MHz calibrator signal measured on the functioning Spectrum Analyzer should measure 2 dB lower than the previous step ( $\sim -27 \text{ dBm}$ ). Press **Mech Atten** and enter 4 dB. The 50 MHz calibrator signal measured on the functioning Spectrum Analyzer should measure an additional 2 dB lower than the previous step ( $\sim -29 \text{ dBm}$ ). If the power levels measure correctly, reconnect W11 cable. If either of these levels is incorrect, Input Attenuator A is the most probable cause, provided the control logic from the A15 Front End Control Assembly was previously verified.

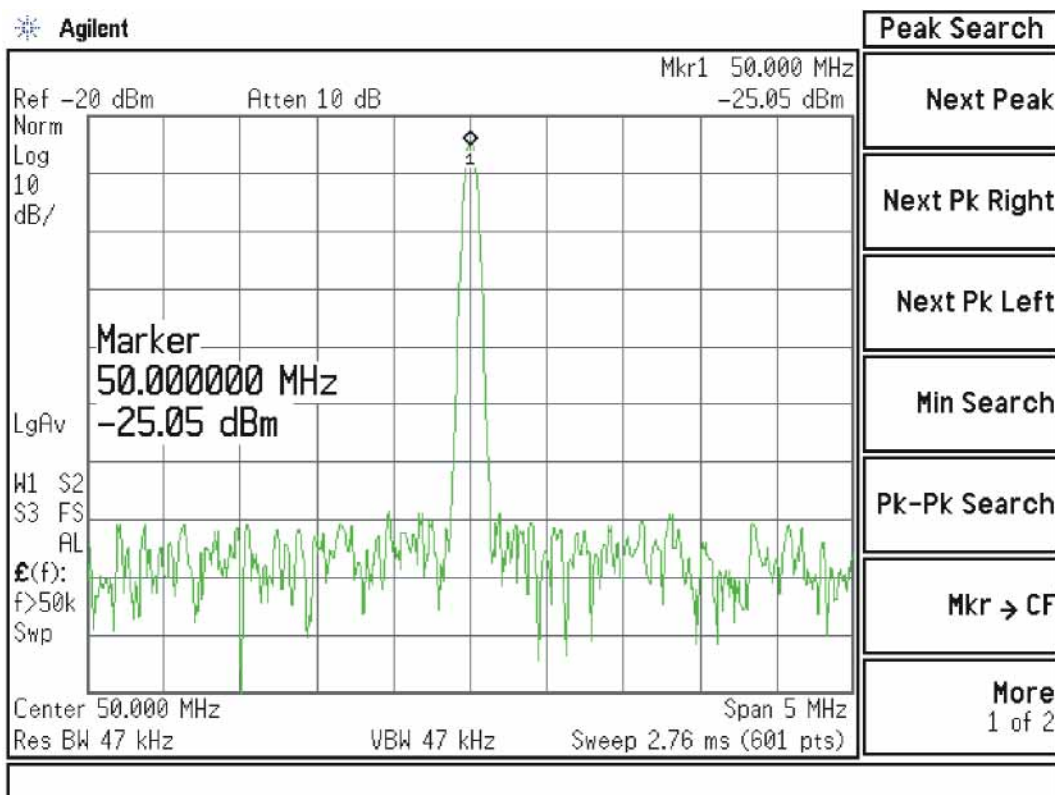


### Input Attenuator B Power Level Verification

Press **AMPTD**, **Attenuation, 0 dB**. Remove output cable W9 from A10 **(2)**. Refer to **Figure 4-13**. Measure the 50 MHz calibrator signal on the output of the attenuator using a functioning Spectrum Analyzer.

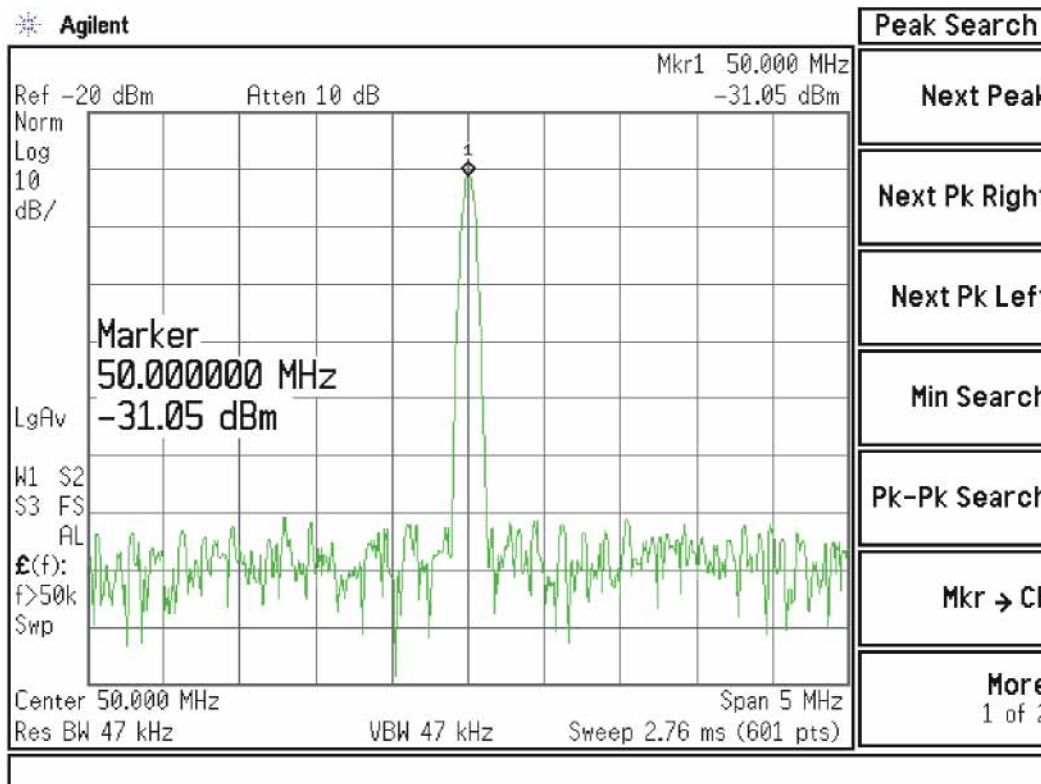
The level should be  $-25 \text{ dBm} \pm 2 \text{ dB}$  as shown in **Figure 4-15**.

Figure 4-15 50 MHz Calibrator Signal on Output of Attenuator B



Press **Mech Atten** and enter 6 dB. The 50 MHz calibrator signal measured on the functioning Spectrum Analyzer should measure 6 dB lower than the previous step (~-31 dBm) as shown in **Figure 4-16**.

**Figure 4-16** 50 MHz Calibrator Signal on Output of Attenuator B (with 6 dB Attenuation)



Press **Mech Atten** and enter 10 dB. The 50 MHz calibrator signal measured on the functioning Spectrum Analyzer should measure 10 dB lower than the first step (~-35 dBm). Continue testing all the attenuation settings as described in **Table 4-11**.

**Table 4-11**

Attenuator Setting (dB)	Expected Level (dBm @ 50 MHz)	Tolerance
16	-41	±3 dB
20	-45	±3 dB
30	-55	±3 dB
40	-65	±4 dB
50	-75	±4 dB
60	-85	±4 dB
66	-91	±4 dB

**NOTE**

1. It may be difficult to measure the higher attenuator settings using the –25 dBm internal calibrator signal. Use an external source with the frequency set to 50 MHz and adjust the output level to 0 dBm. This will increase the measured power levels noted in the table above by 25 dB.
  2. Tolerances should be used as a guideline.
- 

If the power levels measure correctly, reconnect the W9 cable and reset the input attenuation to 10 dB by pressing **Mech Atten, 10 dB** on the analyzer.

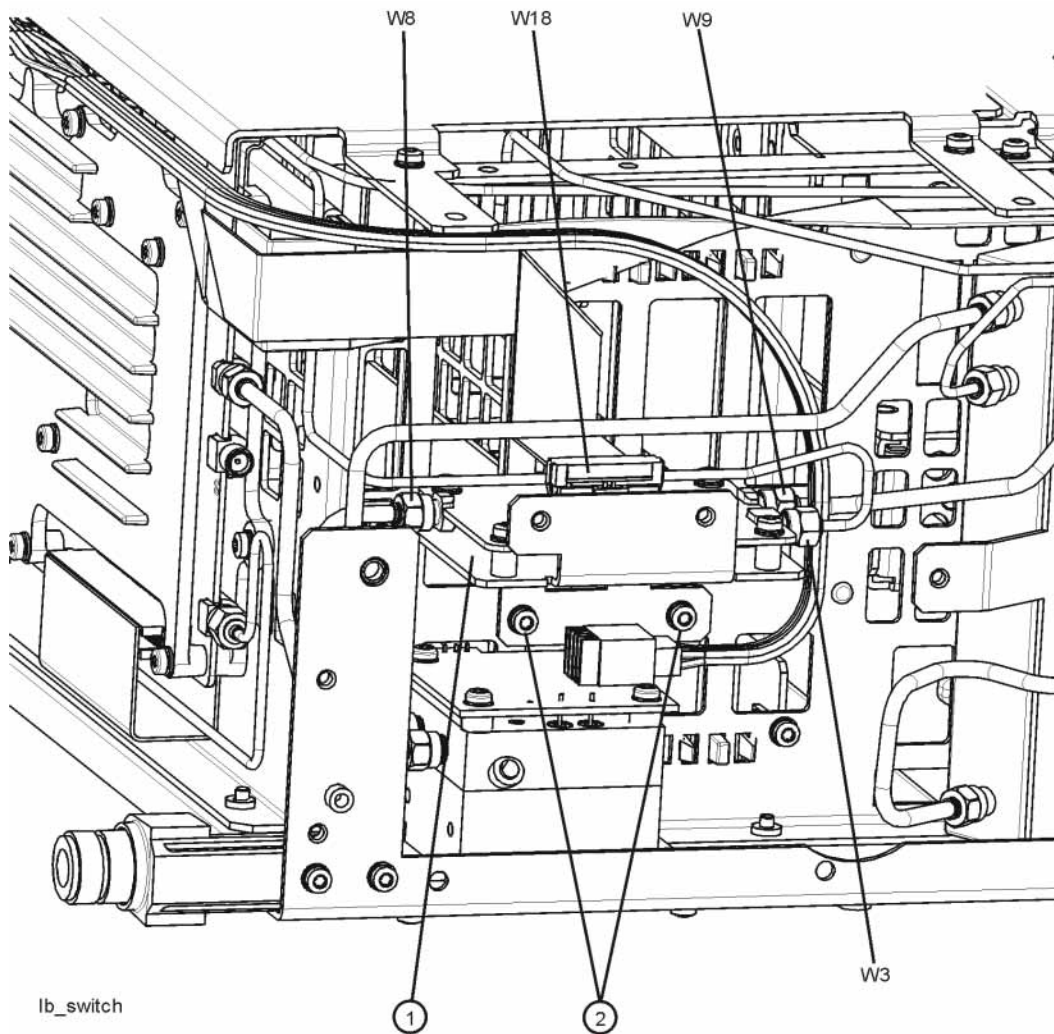
If either of these levels measure incorrectly, Input Attenuator B is the most probable cause, provided the switch control logic has been verified.

### Low Band Switch Power Level Verification

Refer to **Figure 4-17**. Disconnect the W3 cable at A11J2 of the A11 Low Band Switch **(1)**.

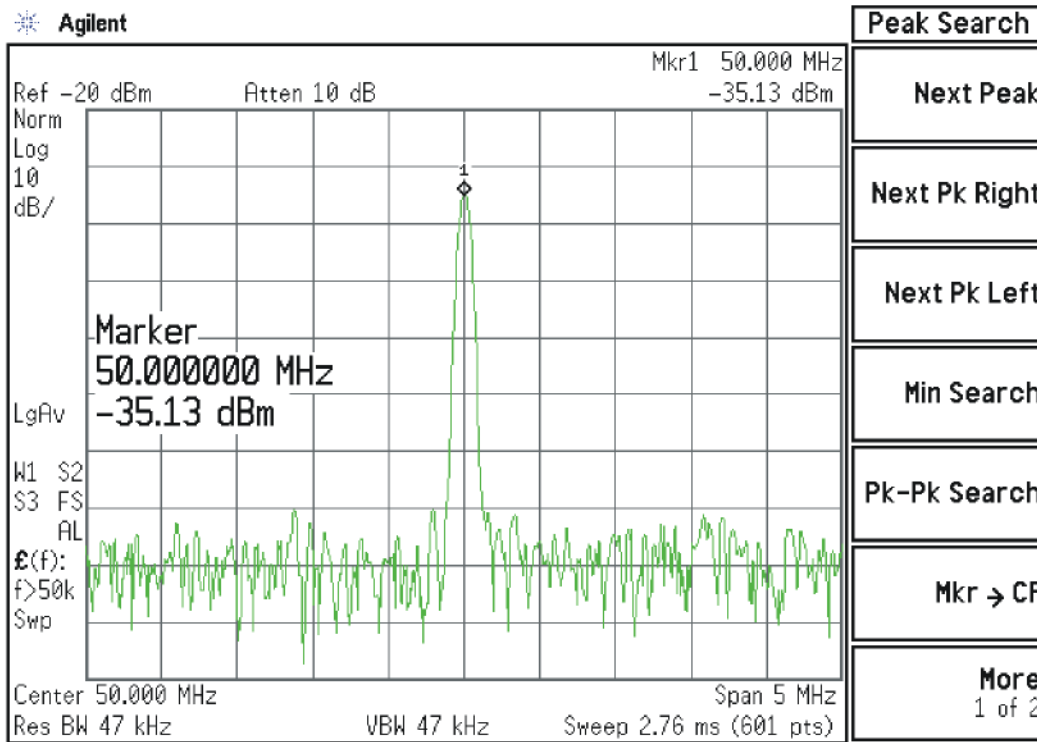
Figure 4-17

Cable W3 Location



When the analyzer is tuned to a center frequency of 50 MHz, the Low Band switch should have minimal loss. Press **Input/Output, RF Calibrator, 50 MHz, AMPTD, Attenuation, 10 dB** on the analyzer. Measure the 50 MHz calibrator signal on the output of A11J2 using a functioning Spectrum Analyzer. The level should be  $-35 \text{ dBm} \pm 5 \text{ dB}$  as shown in **Figure 4-18**.

Figure 4-18 50 MHz Calibrator Signal at Output of W3 Cable



If the power level is incorrect the most probable cause is the low band switch assembly. Reconnect W3 cable.

The following Low Band path items have been verified in the RF section:

- 50 MHz Calibrator signal power level from the A16 Reference Assembly
- 1st L.O. power level from the A14 L.O. Synthesizer
- Switch control logic from the A15 Front End Control Assembly to:
  - Input Attenuator A
  - Input Attenuator B
  - Low Band Switch
  - Front End Assembly
- Input Attenuator A power level check
- Input Attenuator B power level check
- Low Band Switch logic and power level check

If all the power levels and biasing from the A15 Front End Control Assembly measure correctly up to this point, the most probable cause would be the A13 RF Front End Assembly.

## Quick Check to Verify High Band RF Path #1

### (RF Input Frequencies > 3600 MHz and < 13.6 GHz)

Refer to [Chapter 11, “Block Diagrams.”](#) for details.

Equipment needed:

Functioning Spectrum Analyzer

Functioning Signal Generator to 15 GHz

DVM

Cables & Connectors

#### NOTE

To perform the following checks, it will be necessary to remove the outer cover and the top brace. See [Chapter 14](#) for removal procedures.

---

Turn the analyzer on and allow it to complete its full boot up process to Signal Analyzer mode. Use the internal 4.8 GHz, -28 dBm calibrator signal as a reference for troubleshooting by pressing **Mode Preset, Input/Output, RF Calibrator, 4.8 GHz** on the analyzer. Now press **FREQ (Channel), 4.8 GHz, SPAN (X Scale), Zero Span, AMPTD (Y Scale), Attenuation 10 dB** on the analyzer.

#### IMPORTANT

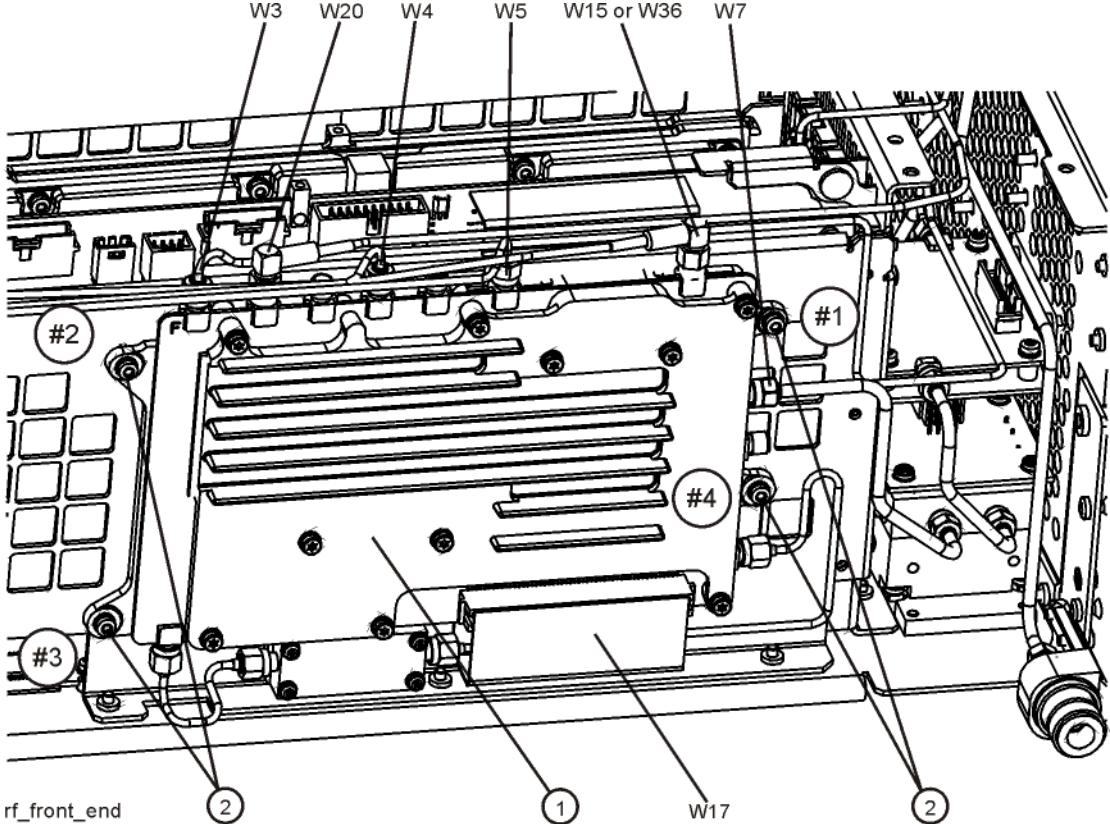
Turn off auto align by pressing **System, Alignments, Auto Align, Off**.

---

Disconnect cable W15 or W36 at A13J7, 322.5 MHz output on the Front End Assembly (1). See **Figure 4-19**.

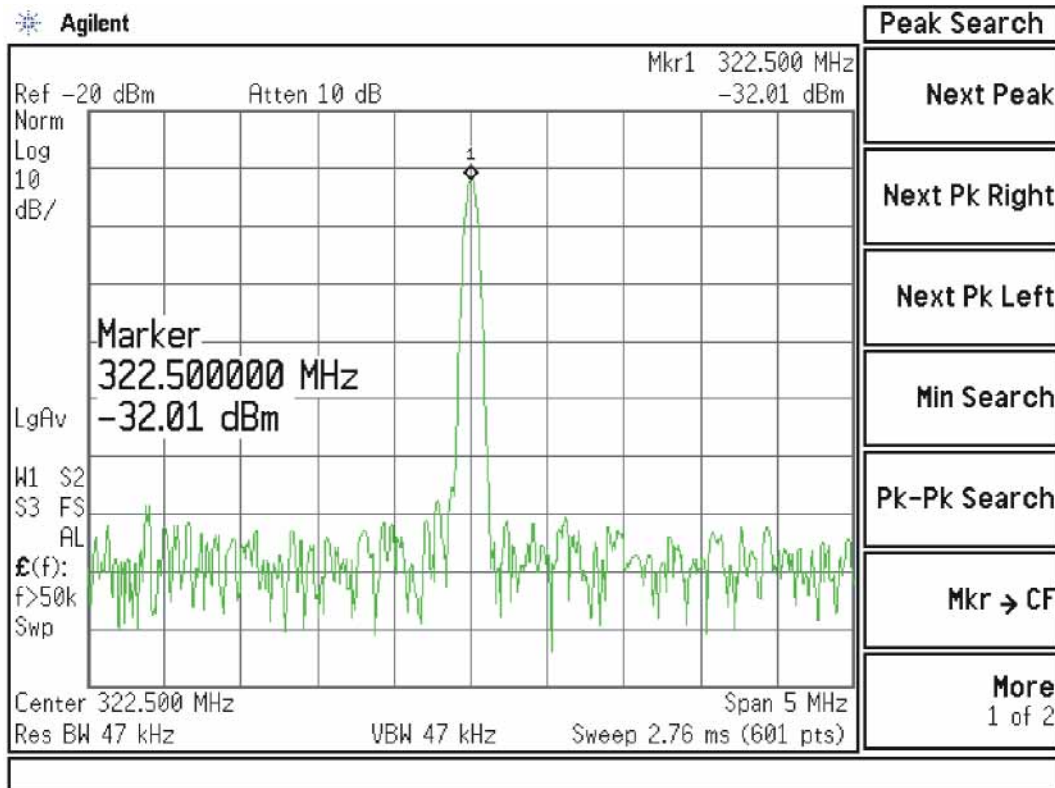
Figure 4-19

W15 or W36 Location



Connect A13J7 output to a functioning spectrum analyzer and verify the 322.5 MHz intermediate frequency is measuring  $-32 \pm 4$  dB as shown in **Figure 4-20**.

Figure 4-20 322.5 MHz Intermediate Frequency



If this power level is correct the entire RF section is operating correctly in high band. If this power level is incorrect verify the following assemblies in the order listed using the 4.8 GHz internal calibrator signal.

1. A16 Reference Assembly
2. A14 L.O. Synthesizer
3. A15 Front End Control Assembly
4. A9 Input Attenuator A
5. A10 Input Attenuator B
6. A11 Low Band Switch
7. A12 YTF Preselector
8. A13 RF Front End Assembly



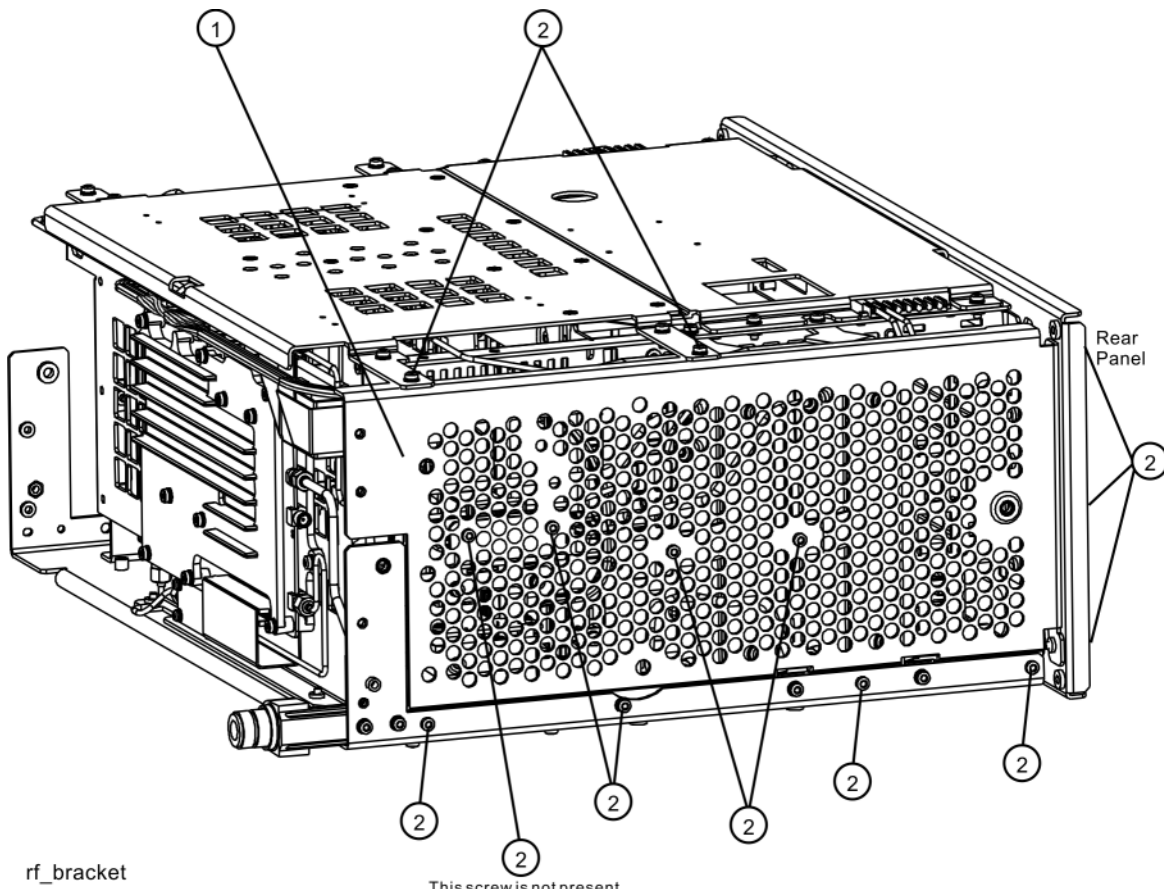
**NOTE**

High Band #2 RF signal path utilizes a high band mixer internal to the A13 RF Front End Assembly for RF input frequencies from 13 GHz to 26.5 GHz. Since all the control voltages and biasing were already fully tested, failures from 13 GHz – 26.5 GHz will most likely be caused by the A13 RF Front End Assembly. If the failure is amplitude related, proper adjustments such as frequency response and the YTF Preselector adjust should be performed first before changing the A13 RF Front End Assembly. Refer to **Chapter 11, “Block Diagrams.”** for details.

In order to gain access to the front end components, remove the side chassis (1). See **Figure 4-21**.

Figure 4-21

Remove the Side Chassis



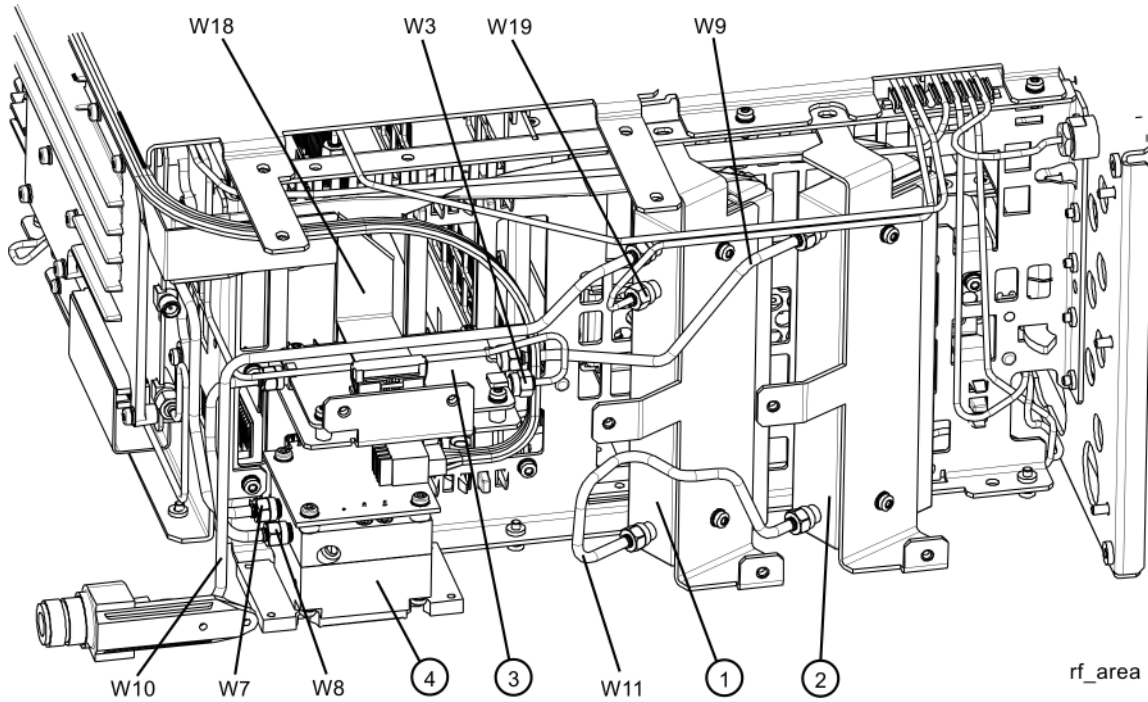
## Troubleshooting a High Band Problem

### 1. Reference Assembly Verification

Refer to **Figure 4-22**. Remove cable W19 from A9 Input Attenuator A **(1)**. Measure the 4.8 GHz calibrator signal on the cable end with a functioning Spectrum Analyzer.

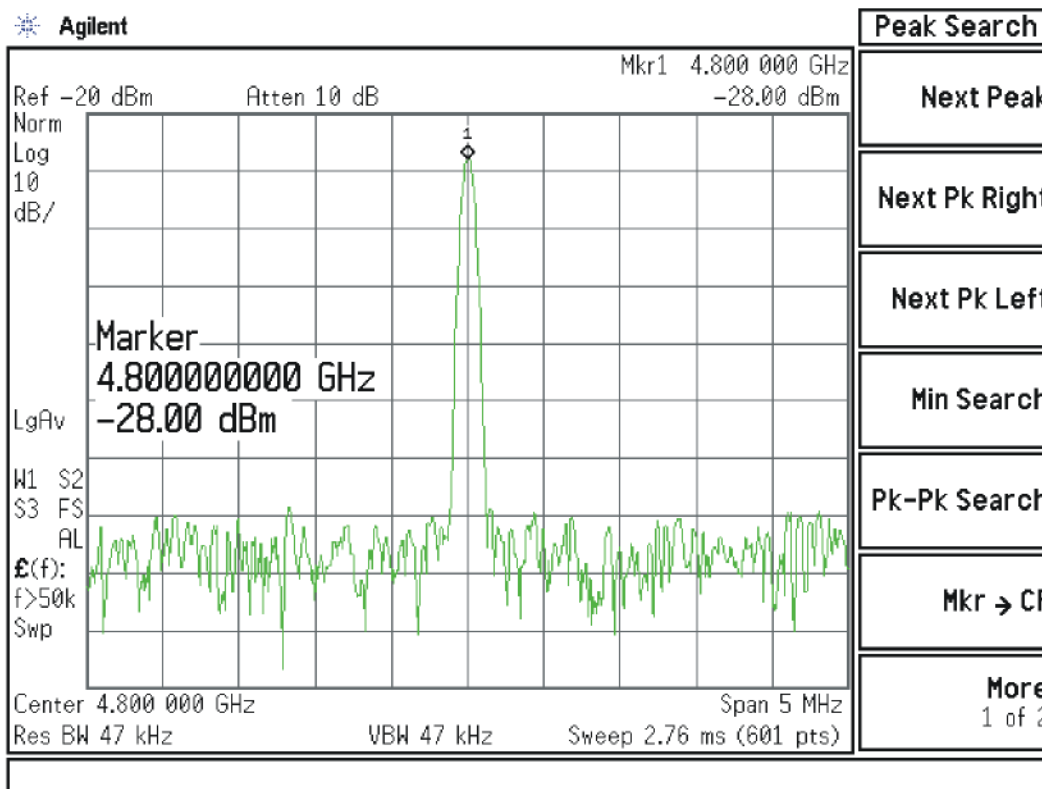
Figure 4-22

W19 Location



If the Reference Assembly calibrator is functioning properly the 4.8 GHz calibrator signal will measure 4.8 GHz at  $-28 \text{ dBm} \pm 3 \text{ dB}$  as shown in **Figure 4-23**. If this level is incorrect, the Reference Assembly is most likely defective. Reconnect W19 at A9 **(1)**.

Figure 4-23 4.8 GHz Calibrator Signal



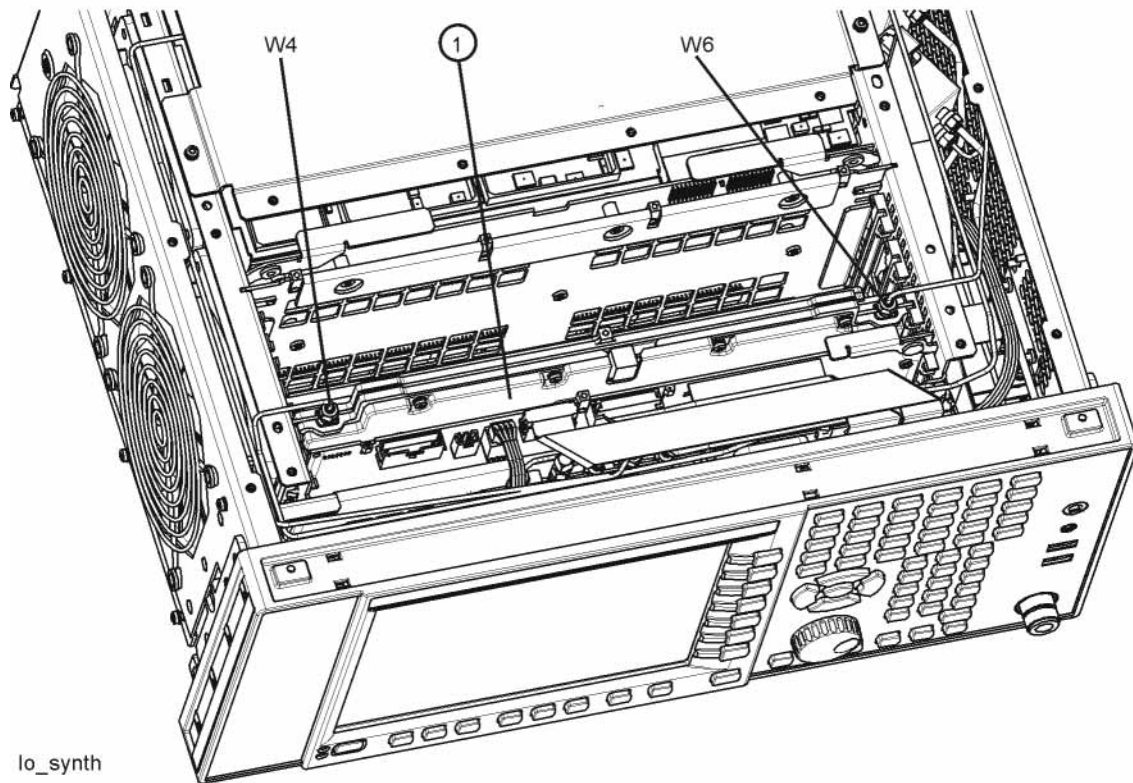
## 2. L.O. Synthesizer Assembly Verification

Press the following keys on the analyzer:

**Mode Preset**  
**FREQ (Channel), 5 GHz**  
**SPAN (X Scale), Zero Span**

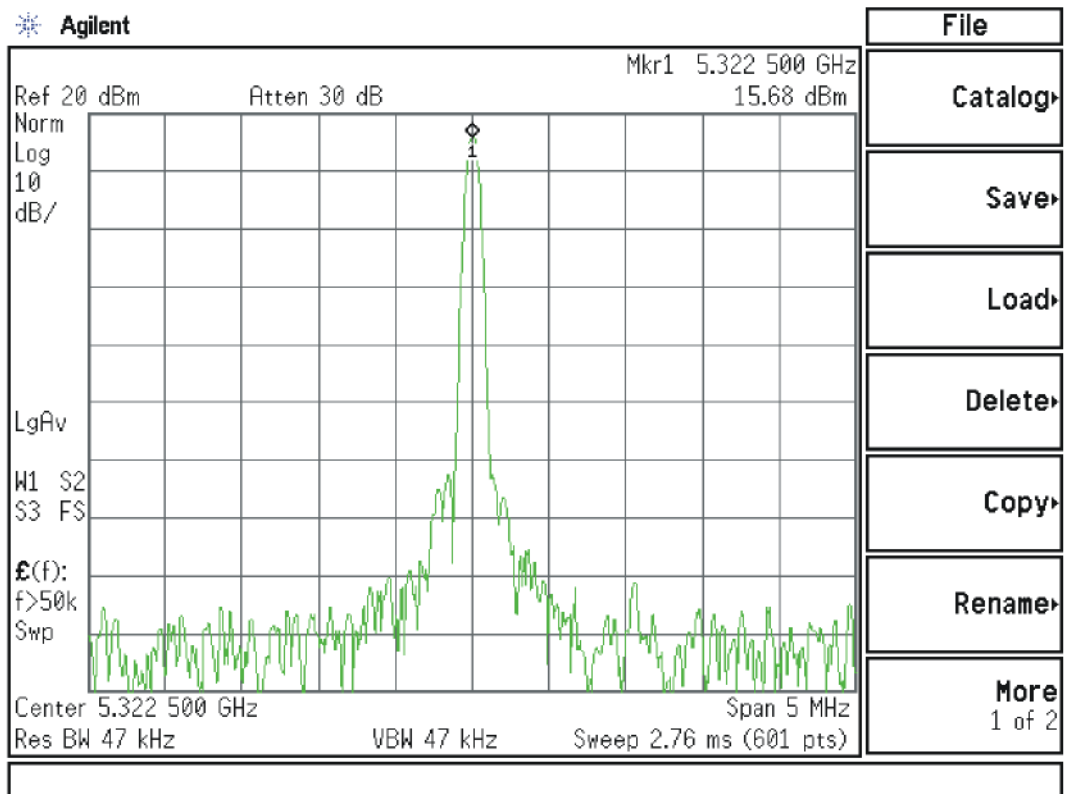
Refer to **Figure 4-24**. Disconnect cable W4 at A14J740 of the L.O. Synthesizer Assembly **(1)**.

Figure 4-24 W4 and W6 Location



Connect the functioning Spectrum Analyzer and appropriate high frequency cable and connector to A14J740. Adjust the analyzer to measure a signal at 5322.5 MHz at +16 dBm  $\pm$  4 dB as shown in **Figure 4-25**.

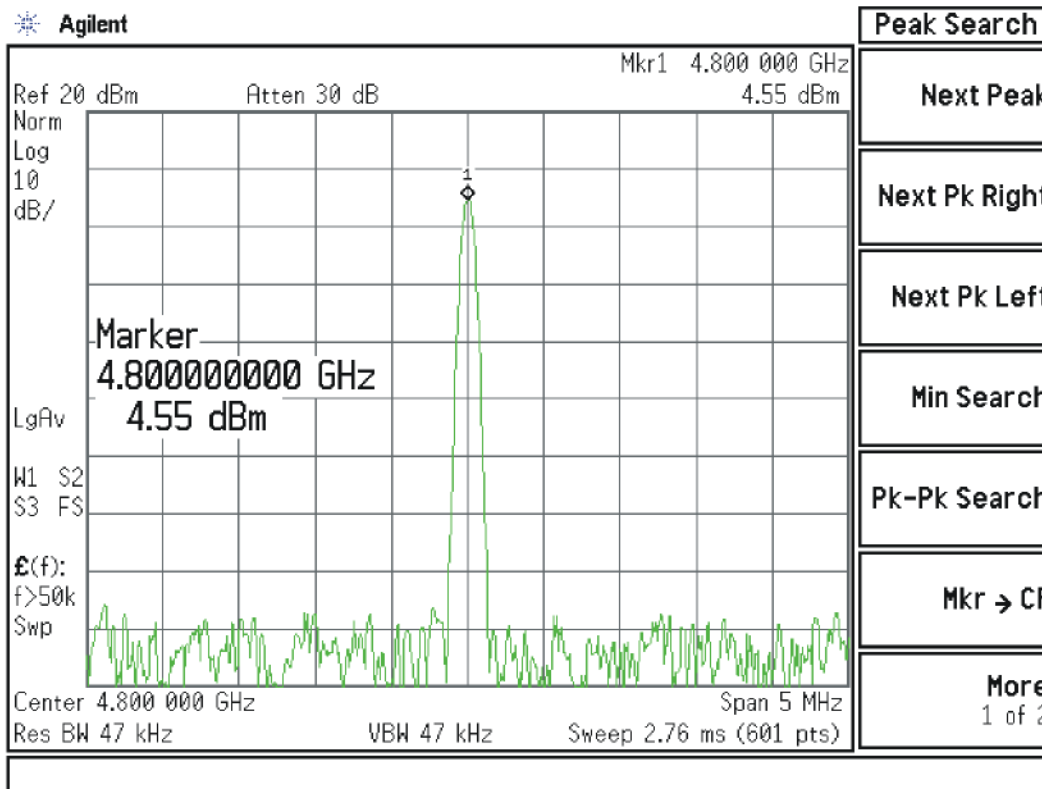
Figure 4-25 Measure 1st L.O.



If this power level is incorrect remove W6 at A14J200. Refer to **Figure 4-24**. Connect the functioning spectrum analyzer to the cable output using the appropriate high-frequency cable.

Adjust the functioning spectrum analyzer to measure a signal at 4.8 GHz at  $+4.5 \text{ dBm} \pm 2 \text{ dB}$  as shown in **Figure 4-26**.

Figure 4-26 4.8 GHz Signal



If this power level is incorrect, the most probable cause is the A16 Reference Assembly. If this level is correct and yet the signal previously measured at A14J740 is incorrect, the most probable cause is the A14 L.O. Synthesizer Assembly. Reconnect W4 cable to A14J740. Reconnect W6 cable to A14J200.

### 3. Front End Control Assembly Verification

**IMPORTANT**

If the Front End Control Assembly logic was verified in the 'Low Band Quick Check' section above, skip to **“Input Attenuator A Power Level Verification”** step below.

---

Verifying the Front End Control Assembly requires the RF Front End Troubleshooting board E4410-60115 or kit number N9020-60005. The kit includes the troubleshooting board and associated interconnect cables. The troubleshooting board and cables will help verify the control logic from this assembly to Input Attenuator A, Input Attenuator B, Low Band Switch, YTF Preselector, (Optional) Low Band Preamplifier, (Optional) High Band Preamplifier, (Optional) Electronic Attenuator and the RF Front End Assembly. The control logic should be verified going to each assembly while the Front End Troubleshooting board is connected.

- Turn off the instrument.
- Connect the E4410-60115 Front End Troubleshooting board to the A15 Front End Control Assembly as shown in **Figure 4-27** and **Figure 4-28**.

Figure 4-27 RF Front End Troubleshooting Board

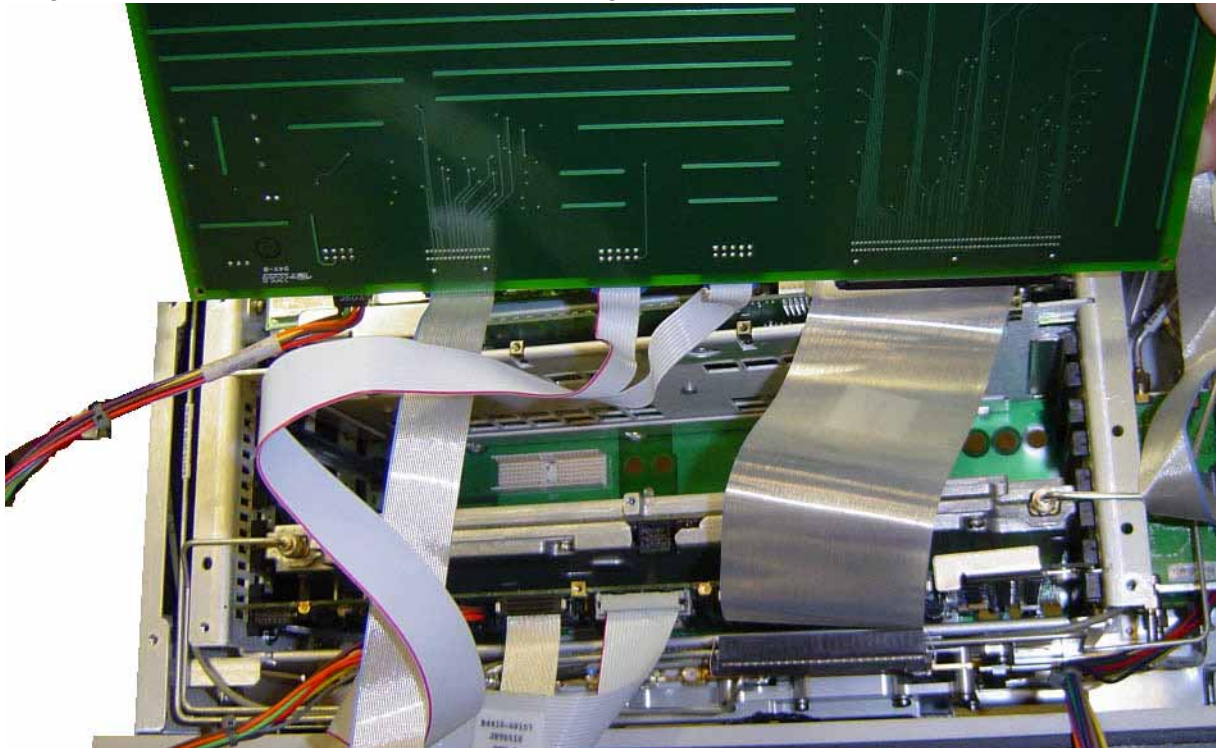
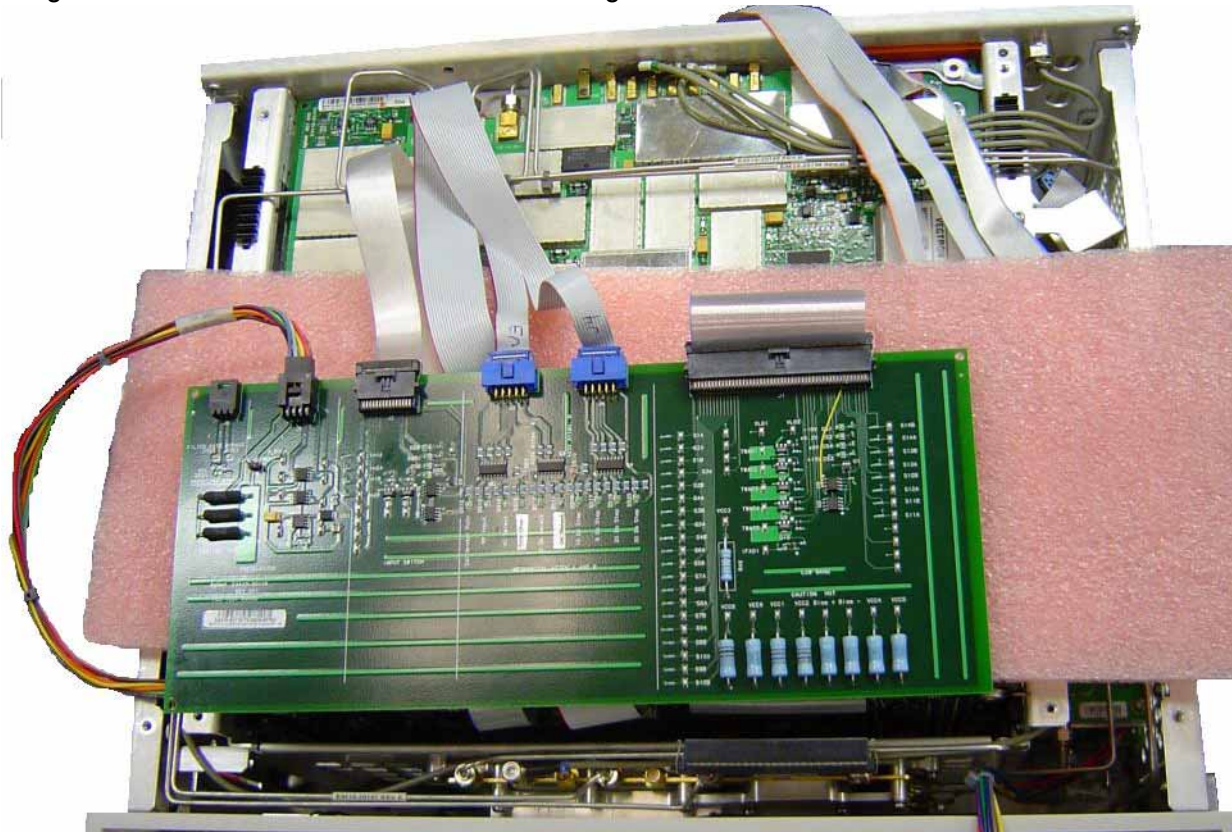


Figure 4-28 RF Front End Troubleshooting Board





- Turn the instrument on and allow it to complete its full boot up process to the signal analyzer application.
- Turn Auto Align off by pressing **System, Alignments, Auto Align, Off** on the analyzer.

**CAUTION**

**Resistors on the board can get very hot.**

---

- Verify all power supply LED's on the Front End Troubleshooting board are turned on. Under the J2 connector, the supplies are +15 VDC, +9 VDC, +5.2 VDC, and –15 VDC. Under the J1 connector, the supplies are +15 VDC, –15 VDC, +9 VDC and +5.2 VDC. Verify both input attenuator power supplies. DS9 under J3 should be on if the +25V supply is up for Attenuator A. DS10 under J4 should be on if the +25V supply is up for Attenuator B. If any of the power supply LED's are not turned on, see [Chapter 2, “Boot Up and Initialization Troubleshooting”](#).
- Press **AMPTD, Attenuation 0 dB**

**NOTE**

The analyzer will display an error dialogue box when booting up. Simply click “OK” so the instrument can complete its boot process. Additionally, the analyzer noise floor will be near the top of the display since the RF assemblies are not powered up. This is normal with the Front End Troubleshooting board connected to the A15 Front End Driver Assembly

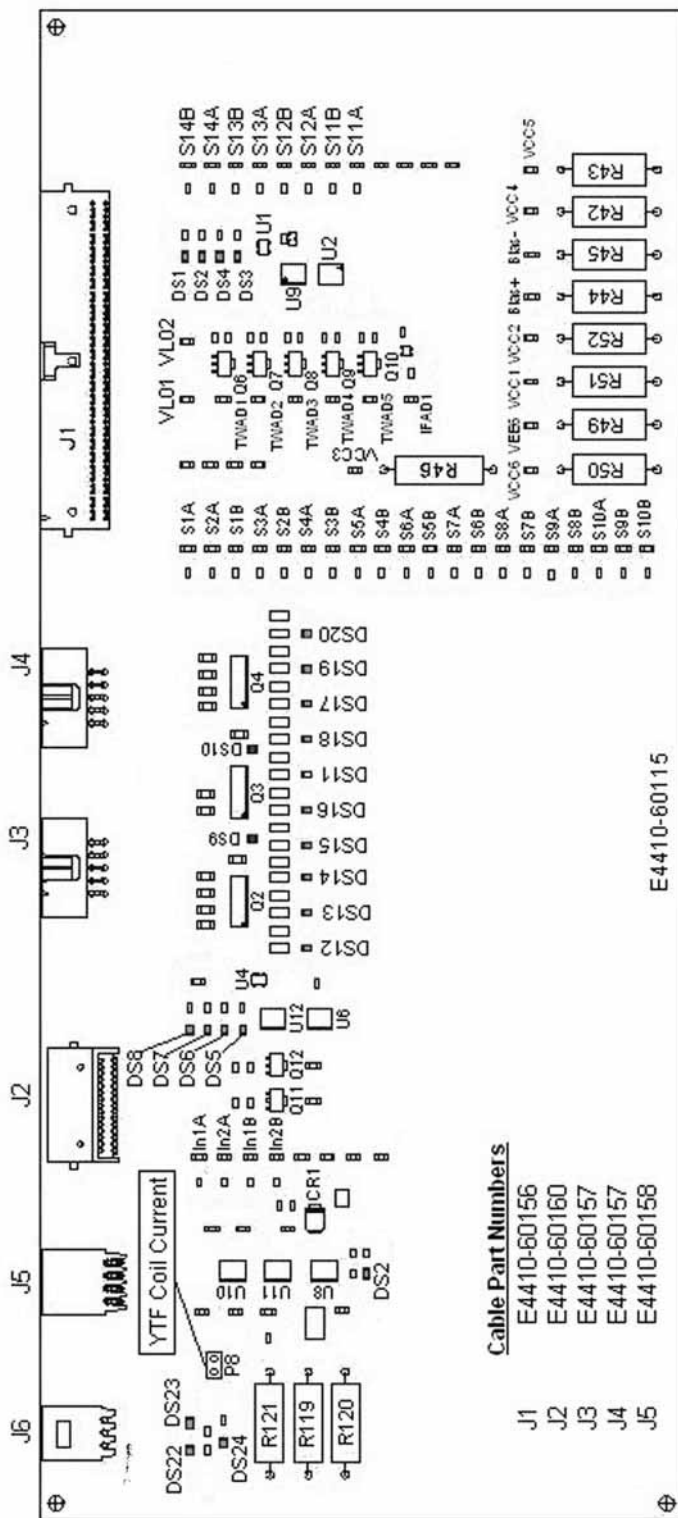
---

#### 4. Input Attenuator A Control Logic Verification

All the attenuation LED's on the Front End Troubleshooting board should be off except for DS9 and DS10, +25V supply for Attenuator A and Attenuator B.

Figure 4-29

Front End Troubleshooting Board Attenuation LEDs



When the input attenuation is changed from 0 dB to 2 dB, the 2 dB Step LED DS15 should illuminate. When the input attenuation is changed from 2 dB to 4 dB, DS15 and DS16 should be illuminated as per [Table 4-12](#).

Table 4-12 Attenuator A Logic

Attenuator Setting (dB)	DS15	DS16
0		
2	X	
4	X	X

The analyzer default setting for RF Coupling is AC mode. Verify the AC Select LED DS14 is illuminated at this time. Set **Input/Output, RF Input, RF Coupling** to DC. DS14 turns off, DS11 DC Select yellow LED should illuminate. Switch the RF Coupling back to AC. If the LED's illuminate correctly, the switch control logic to Input Attenuator A from the A15 Front End Control Assembly is correct. If the LED's are not illuminating as expected, the most probable cause is the A15 Front End Control Assembly.

### 5. Input Attenuator B Control Logic Verification

Press **AMPTD, Attenuation 6 dB** and verify the 6 dB Step LED DS17 is illuminated. Enter the input attenuation settings found in **Table 4-13** and verify the proper LED's illuminate on the Front End Troubleshooting board according to **Table 4-13**.

Table 4-13

Attenuator B Logic

Attenuator Setting (dB)	DS20 30 dB Step LED	DS19 20 dB Step LED	DS18 10 dB Step LED	DS17 6 dB Step LED
10			X	
16			X	X
20		X		
30	X			
40	X		X	
50	X	X		
60	X	X	X	
66	X	X	X	X

Set the input attenuator back to 10 dB by pressing **AMPTD, Attenuation, 10 dB** on the analyzer. If the LED's illuminate correctly, the switch control logic for the input attenuators from the A15 Front End Control Assembly is correct. If the LED's are not illuminating as expected, the most probable cause is the A15 Front End Control Assembly.

## 6. Low Band Switch Control Logic Verification

Press **Mode Preset** on the analyzer. Press **FREQ, 50 MHz, SPAN, 2 MHz** on the analyzer. Connect the DVM positive lead to one of the In1A test points, and the negative lead to the bottom of R46 (blue resistor near the bottom) on the Front End Troubleshooting board. Verify the voltages in [Table 4-14](#).

Table 4-14

Test Point	Voltage
In1A	-9.85
In2A	-9.85
In1B	+9.75
In2B	+9.75

Press **Freq 5 GHz** on the analyzer. Verify the voltages in [Table 4-15](#).

Table 4-15

Test Point	Voltage
In1A	+9.72
In2A	-9.84
In1B	-9.84
In2B	+9.72

If the voltages are not correct, the most probable cause is the A15 Front End Control Assembly.

## 7. YTF Preselector Control Logic Verification

### NOTE

In order to properly measure the preselector tune output from the A15 Front End Control Assembly, the following items are required:

- E9637A Banana plug to BNC (f) adapter
- E9632A BNC (M) to SMA (f)
- 8120-1460 Small coaxial cable SMA (m) to mmcX (m)

---

Connect the mmcX end of the cable to A15J300, preselector tune output at the upper left corner of A15 Front End Control Assembly.

Press **Single** on the analyzer. Verify the voltages in **Table 4-16** as the center frequency of the analyzer is changed.

Table 4-16

YTF Tune Voltages

Center Frequency (GHz)	~ Tune Voltage (VDC)	Tolerance (VDC)
5.0	1.6	±0.5
10 <sup>a</sup>	3.228	±1.0
15 <sup>b</sup>	4.85	±1.0
20 <sup>b</sup>	6.5	±1.0
26 <sup>b</sup>	8.45	±1.0

a. Options 513 and 526

b. Option 526

### NOTE

Tolerances can be used as a guideline. The true test is whether or not the analyzer will function and meet published specification.

---

If any of the preselector tune voltages do not match the levels in **Table 4-16**, the most probable causes are a misaligned YTF or the A15 Front End Control Assembly. Perform the YTF characterization (press **System, Alignments, More, Advanced, Characterize Preselector**).

To further test the YTF control current, select Amps on the DVM and place the positive lead of the DVM on one of the YTF Coil Current P8 pins and the other DVM lead to the other Coil Current pin.

**NOTE** In order to measure the control current correctly, press **Single** on the analyzer in between each measurement.

---

If any of the preselector control currents do not match the levels in **Table 4-17**, the most probable causes are a misaligned YTF or the A15 Front End Control Assembly. Perform the YTF characterization (press **System, Alignments, More, Advanced, Characterize Preselector**) and re-check the control current at various center frequencies.

Table 4-17 YTF Tune Current

Center Frequency (GHz)	Control Current (mA)	Tolerance (mA)
5.0	106	±20
10 <sup>a</sup>	215	±25
15 <sup>b</sup>	324	±30
20 <sup>b</sup>	430	±40
26 <sup>b</sup>	560	±50

- a. Options 513 and 526
- b. Option 526

**NOTE** Tolerances should be used as a guideline. The true test is whether or not the analyzer will function and meet published specification.

---

## 8. Front End Assembly Control Logic Verification

Since the RF Front End Troubleshooting board is connected, now is a good time to test out the remaining control circuits from the A15 Front End Control Assembly.

Table 4-18 Front End Control Logic

Test Point	Description	Instrument Settings	Voltage (VDC)	Tolerance (VDC)
S2A	Sets switch for Low Band/preamp path	CF 50 MHz preamp on	+9.67	±0.5
S2B	Sets switch for Low Band/preamp path	CF 50 MHz preamp on	+9.83	±0.5
S3A	Sets E-atten to 5 dB preamps off	E-atten = 5 dB	+9.67	±0.5
S3B	Sets E-atten to 5 dB preamps off	E-atten = 5 dB	+9.83	±0.5
S4A	Sets E-atten to 10 dB preamps off	E-atten = 10 dB	+9.67	±0.5
S4B	Sets E-atten to 10 dB preamps off	E-atten = 10 dB	+9.83	±0.5
S5A	Sets E-atten to 2 dB preamps off	E-atten = 2 dB	+9.67	±0.5
S5B	Sets E-atten to 2 dB preamps off	E-atten = 2 dB	+9.83	±0.5
S6A	Sets E-atten to 1 dB preamps off	E-atten = 1 dB	+9.67	±0.5
S6B	Sets E-atten to 1 dB preamps off	E-atten = 1 dB	+9.83	±0.5
S7A	Sets E-atten to 2 dB preamps off	E-atten = 2 dB	+9.67	±0.5
S7B	Sets E-atten to 2 dB preamps off	E-atten = 2 dB	+9.83	±0.5
S8A	Sets E-atten to 20 dB preamps off	E-atten = 20 dB	+9.67	±0.5
S8B	Sets E-atten to 20 dB preamps off	E-atten = 20 dB	+9.83	±0.5
S9A	Controls in & out to low band preamps off	E-atten = off	+9.83	±0.5
S9B	Controls in & out to low band preamps off	E-atten = off	+9.67	±0.5
S11A	Sets path for 1st or 2nd L.O.	CF 1 GHz	+9.67	±0.5
S11B	Sets path for 1st or 2nd L.O.	CF 1 GHz	+9.83	±0.5
S12A	Sets path for L.O. normal or x2 for band 4	CF 1 GHz	+9.83	±0.5
S12B	Sets path for L.O. normal or x2 for band 4	CF 1 GHz	+9.67	±0.5
S13A	Sets path for L.O. to either of the high band mixers and L.O. output	CF 5 GHz CF 20 GHz	-9.67 +9.67	±0.5
S13B	Sets path for L.O. to either of the high band mixers and L.O. output	CF 5 GHz CF 20 GHz	+9.83 -9.83	±0.5



Table 4-18 Front End Control Logic

Test Point	Description	Instrument Settings	Voltage (VDC)	Tolerance (VDC)
S14A	Sets path to either band 1 & 2 mixer or band 3 & 4 mixer	CF 5 GHz CF 20 GHz	-9.83 +9.83	±0.5
S14B	Sets path to either band 1 & 2 mixer or band 3 & 4 mixer	CF 5 GHz CF 20 GHz	+9.67 -9.67	±0.5
VCC1	Voltage always on		4.8	±0.5
VCC2	Voltage always on		4.8	±0.5
VCC3	Voltage always on		7.85	±0.5
VCC4	Voltage always on		5.0	±0.5
VCC5	Voltage always on		5.0	±0.5
TWAD1	Amplifier bias to A13 RF Front End Assembly		6.0	±0.5
TWAD2	Amplifier bias to A13 RF Front End Assembly		6.0	±0.5
TWAD3	Amplifier bias to A13 RF Front End Assembly		6.0	±0.5
TWAD4	Amplifier bias to A13 RF Front End Assembly		6.0	±0.5
TWAD5	Amplifier bias to A13 RF Front End Assembly		6.0	±0.5

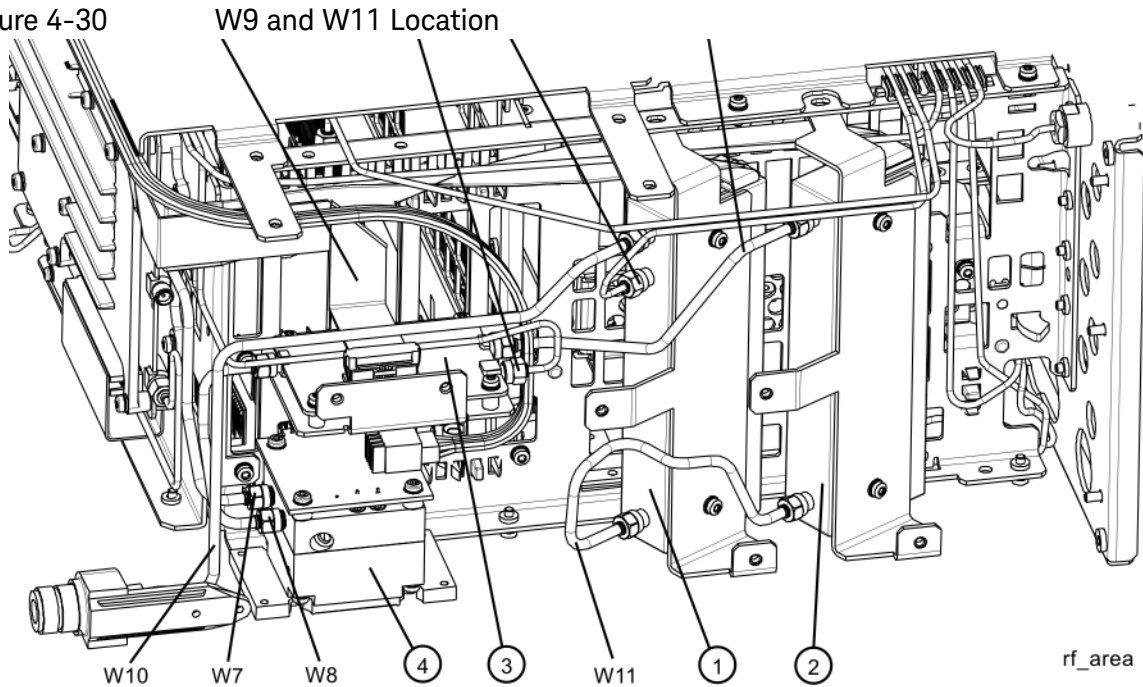
**NOTE** Tolerances should be used as a guideline.

If any of the voltages measured do not match the levels in [Table 4-18](#), the most probable cause is the A15 Front End Control Assembly. Once the switch control logic has been verified, turn off the instrument. Disconnect the RF Front End Troubleshooting board cables, and reconnect the analyzer cables to the A15 Front End Control Assembly. Turn the instrument on and allow it to complete its full boot up process to Spectrum Analyzer mode.

### Input Attenuator A Power Level Verification

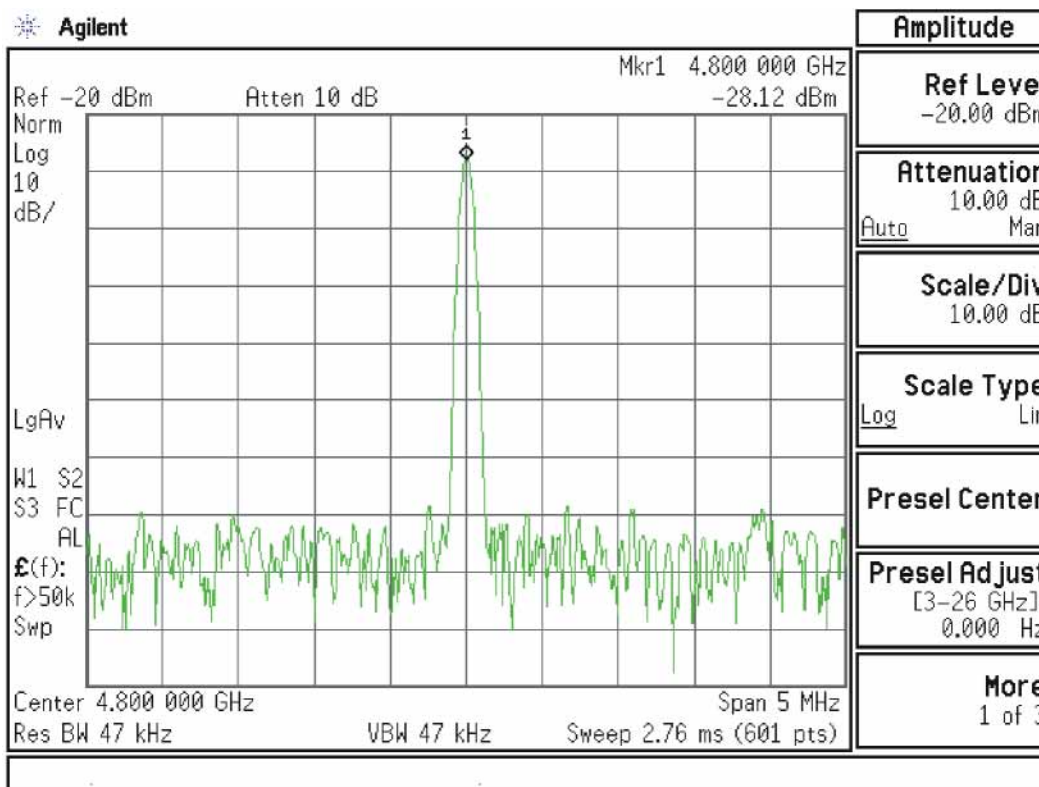
Press **Mode Preset, Input/Output, RF Calibrator, 4.8 GHz, AMPTD, Attenuation, 0 dB** on the analyzer. Refer to [Figure 4-30](#), remove cable W11 from A9 (1) Output. Measure the 4.8 GHz calibrator signal on the output of the attenuator using the proper high frequency cables and connect to the functioning Spectrum Analyzer.

Figure 4-30



The level should be  $-28 \text{ dBm} \pm 2 \text{ dB}$  as shown in [Figure 4-31](#).

Figure 4-31 4.8 GHz Calibrator Signal on Output of Attenuator A



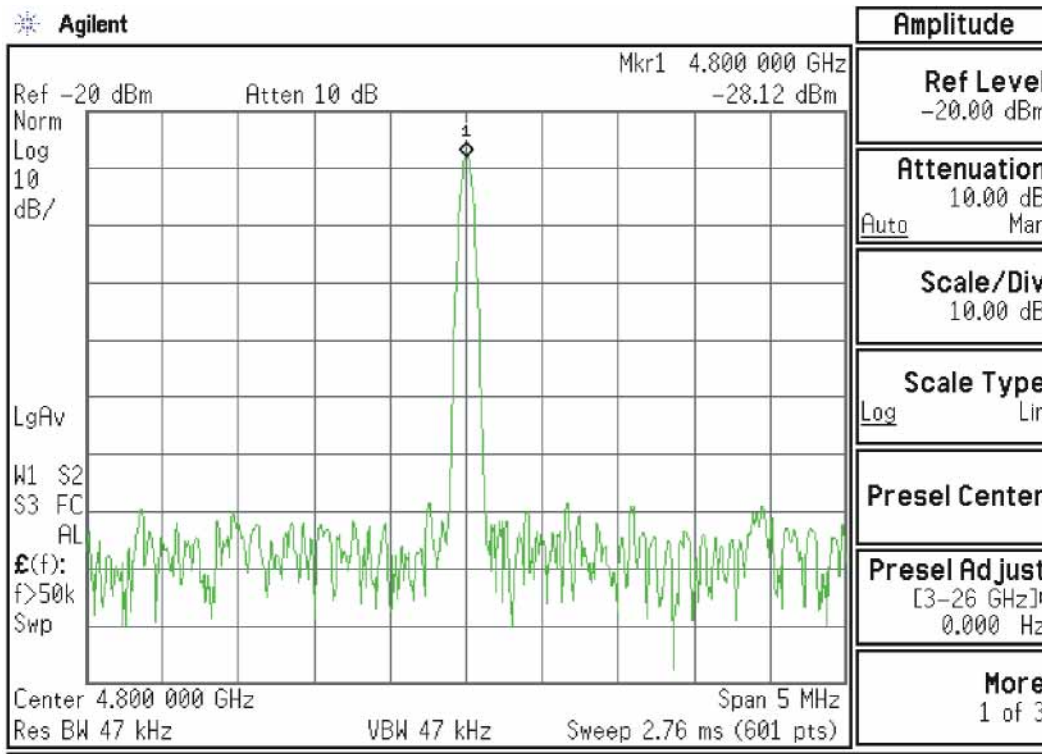
Press **Mech Atten** and enter 2 dB. The 4.8 GHz calibrator signal measured on the functioning Spectrum Analyzer should measure 2 dB lower than the previous step ( $\sim -30 \text{ dBm}$ ). Press **Mech Atten** and enter 4 dB. The 4.8 GHz calibrator signal measured on the functioning Spectrum Analyzer should measure an additional 2 dB lower than the previous step ( $\sim -32 \text{ dBm}$ ). If the power levels measure correctly, reconnect W11 cable. If either of these levels is incorrect, Input Attenuator A is the most probable cause, provided the control logic from the A15 Front End Control Assembly was previously verified.

#### Input Attenuator B Power Level Verification

Press **AMPTD, Attenuation, 0 dB**. Remove output cable W9 from A10 (2). Refer to [Figure 4-30](#). Measure the 4.8 GHz calibrator signal on the output of the attenuator using a functioning Spectrum Analyzer.

The level should be  $-28 \text{ dBm} \pm 2 \text{ dB}$  as shown in [Figure 4-32](#).

Figure 4-32 4.8 GHz Calibrator Signal on Output of Attenuator B



Press **Mech Atten** and enter 6 dB. The 4.8 GHz calibrator signal measured on the functioning Spectrum Analyzer should measure 6 dB lower than the previous step ( $\sim -34 \text{ dBm}$ ).

Press **Mech Atten** and enter 10 dB. The 4.8 GHz calibrator signal measured on the functioning Spectrum Analyzer should measure 10 dB lower than the first step ( $\sim -38 \text{ dBm}$ ). Continue testing all the attenuation settings as described in [Table 4-19](#).

Table 4-19

Attenuator Setting	Expected Level dBm @ 4.8 GHz	Tolerance
16	-44	$\pm 3 \text{ dB}$
20	-48	$\pm 3 \text{ dB}$
30	-58	$\pm 3 \text{ dB}$
40	-68	$\pm 4 \text{ dB}$
50	-78	$\pm 4 \text{ dB}$
60	-88	$\pm 4 \text{ dB}$
66	-94	$\pm 4 \text{ dB}$

**NOTE**

1. It may be difficult to measure the higher attenuator settings using the  $-28$  dBm internal calibrator signal. Use an external source with the frequency set to 4.8 GHz and adjust the output level to 0 dBm. This will increase the measured power levels noted in the table above by 28 dB.
  2. Tolerances should be used as a guideline.
- 

If the power levels measure correctly, reconnect the W9 cable and reset the input attenuation to 10 dB by pressing **Mech Atten, 10 dB** on the analyzer.

If either of these levels measure incorrectly, Input Attenuator B is the most probable cause, provided the switch control logic has been verified.

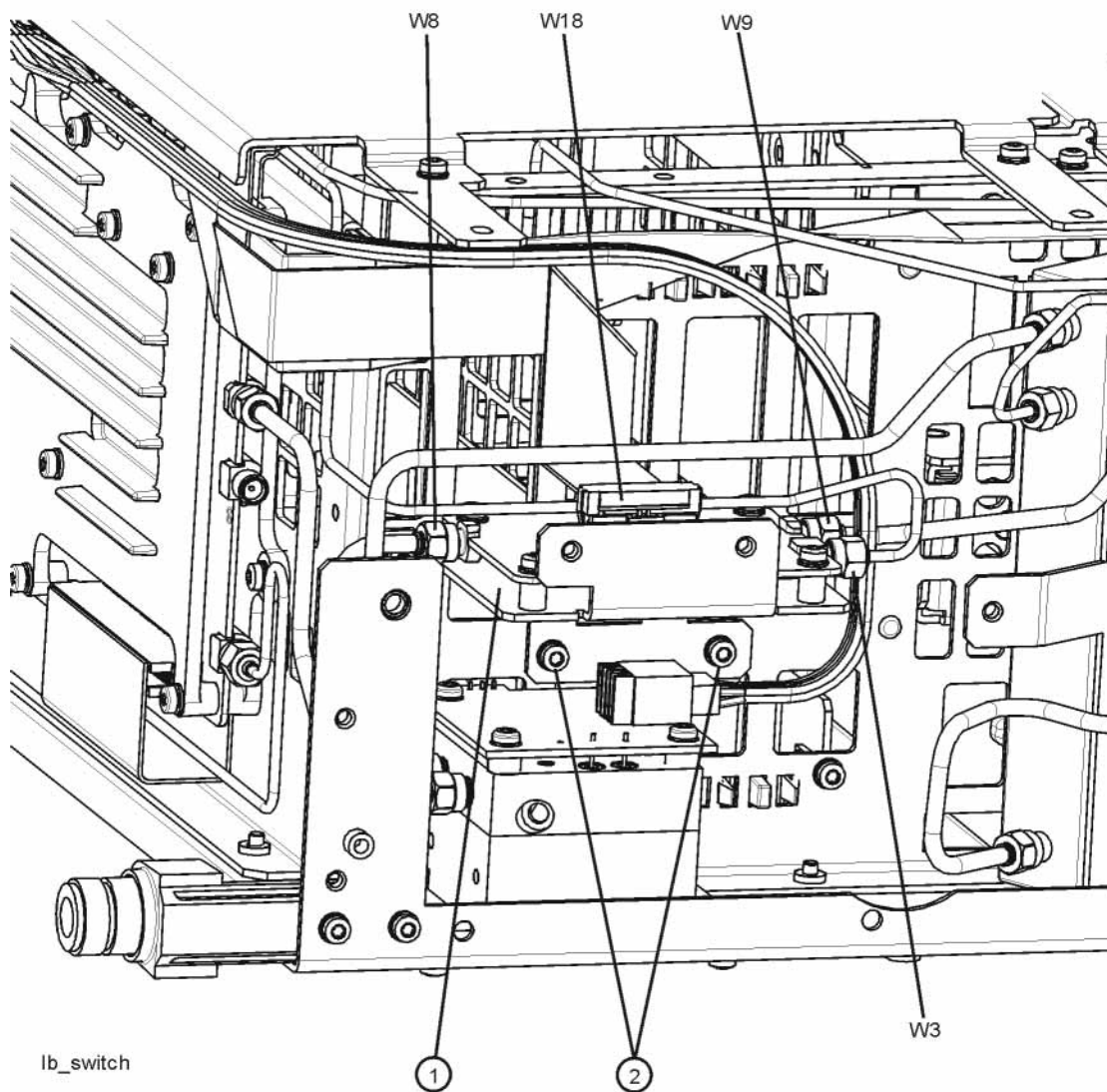
### Low Band Switch Power Level Verification

(for High Band)

Refer to **Figure 4-33**. Carefully disconnect both ends of the W8 cable at A11J3 and A12 **(1)** input. If the microwave preselector bypass hardware is installed, disconnect both ends of W31 at A11J3 and SW2 port C.

Figure 4-33

W8 Location



**CAUTION**

Be careful not to short out components on the front panel interface board or the components on top of the A12 YTF Preselector when removing W8 or W31.

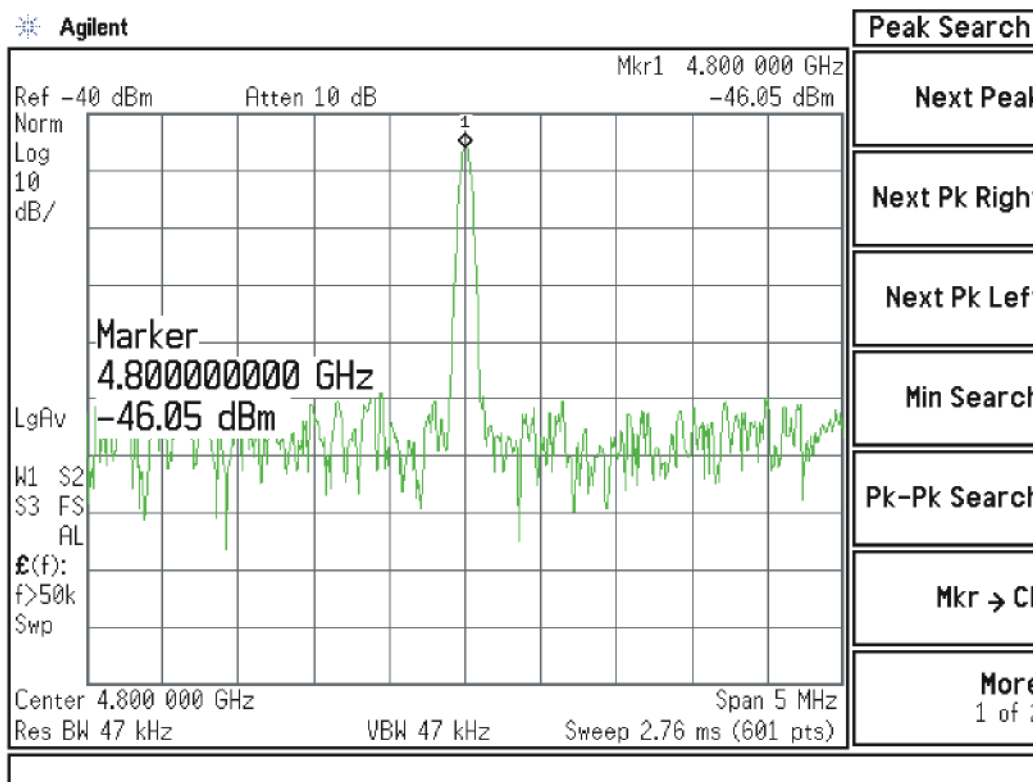
RF Section Troubleshooting  
Troubleshooting

Press **Input/Output**, **RF Calibrator**, **4.8 GHz**, **AMPTD**, **Attenuation**, **10 dB**, **FREQ**, **4.8 GHz**, **SPAN**, **Zero Span** on the analyzer.

**IMPORTANT** Turn off auto align by pressing **System, Alignments, Auto Align, Off**.

Measure the 4.8 GHz calibrator signal on the output of A11 J3 Low Band Switch high band output port using a functioning Spectrum Analyzer. The level should be  $-46 \text{ dBm} \pm 3 \text{ dB}$  as shown in **Figure 4-34**. There is  $\sim 8 \text{ dB}$  of loss through the A11 Low Band Switch when using the 4.8 GHz reference signal.

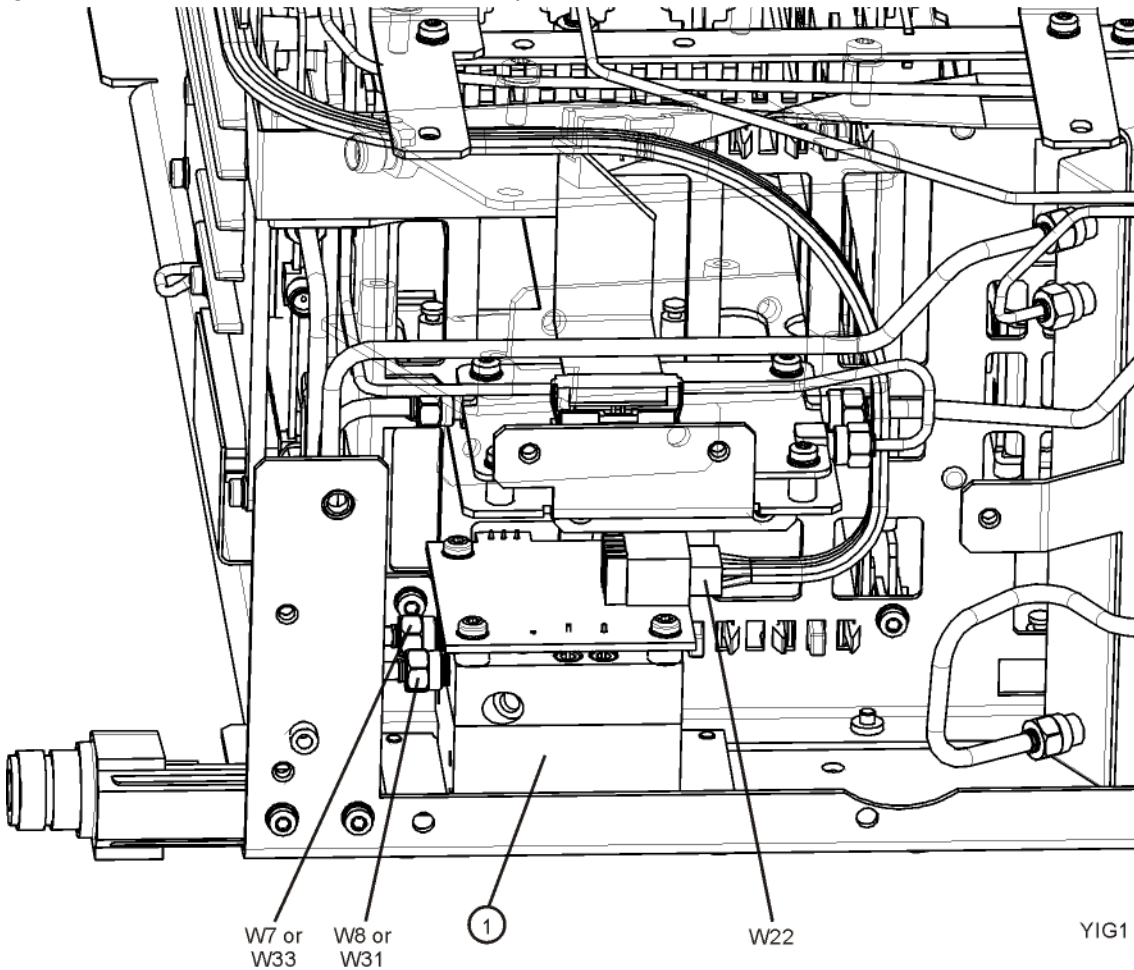
Figure 4-34 4.8 GHz Calibrator Signal at Output of W8 Cable





If the power level is correct, do not reconnect W8 or W31 at this time. Refer to **Figure 4-35**, disconnect W7 at A12 **(1)** output and install a connector such that the A12 YTF Preselector output can be measured. If the preselector bypass hardware is installed, disconnect W33 at A12.

Figure 4-35 Cable W7 at A12 Output



Once the connector is installed, carefully reconnect W8 or W31 to make the measurement. If the power level is incorrect, the most probable cause is the A12, YTF Preselector.

### A12 YTF Preselector Power Level Verification

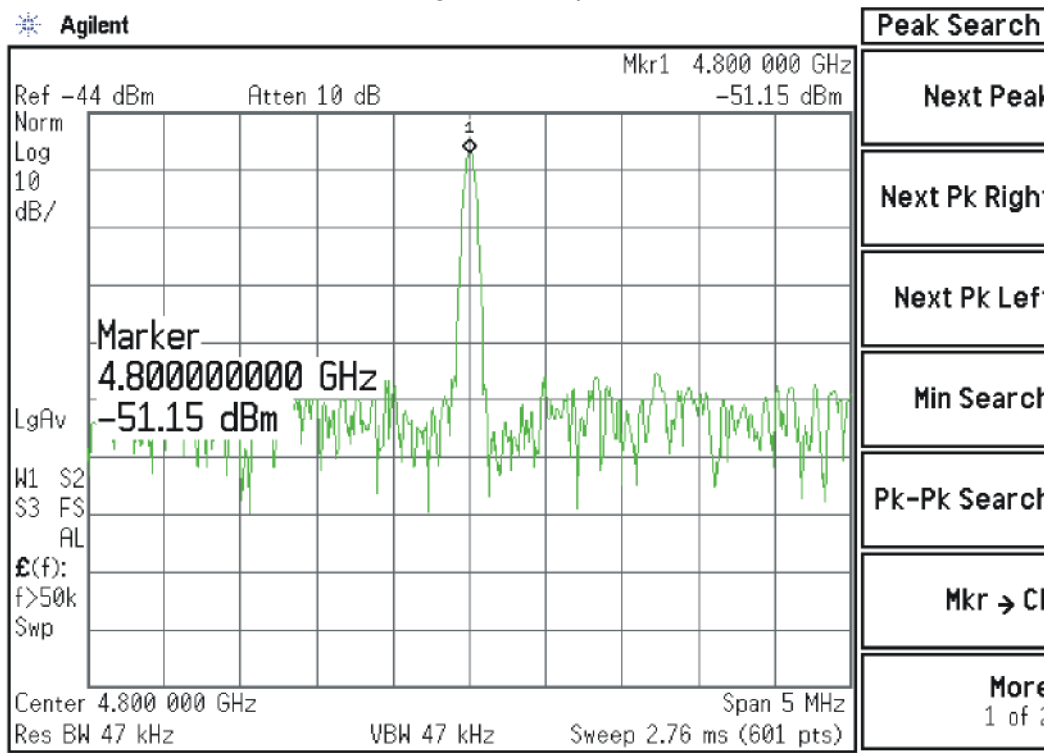
Press **Input/Output, RF Calibrator, 4.8 GHz, AMPTD, Attenuation, 10 dB, SPAN (X Scale), Zero Span** on the analyzer. Measure the 4.8 GHz calibrator on the output of either the W7 (or, if the microwave preselector bypass hardware is installed, W34) cable using a functioning spectrum analyzer. When the 4.8 GHz calibrator signal is used, there will be ~ 5 dB (~8 dB if microwave preselector bypass hardware is installed)  $\pm$  4 dB of insertion loss through the YTF Preselector. The tolerance is large because the A12 YTF loss varies between devices, and the YTF might not be perfectly aligned, or the frequency response adjustment may be required.

If the signal level is incorrect, and Option MPB, Microwave Preselector Bypass is installed and licensed, press **AMPTD, More, uW Path Control, uW Preselector Bypass**. If the signal level is now ~ - 51 dBm  $\pm$  4 dB as shown in **Figure 4-36**, suspect the A12 YTF is either out of adjustment or faulty.

To perform the YTF alignment, reconnect W7 or W34 and press **System, Alignments, More, Advanced, Characterize Preselector**. The routine may take several minutes to align the YTF. Display the 4.8 GHz calibrator on screen as explained in the quick check section. If the signal level is still incorrect, suspect all assemblies, cables, and switches between the W7 (or W34) cable and the output of the A11 Low Band Switch.

Reconnect W7 and W8 cables (or W31 and W34 cables).

Figure 4-36 4.8 GHz Calibrator Signal at Output of W7 Cable



If the power level is incorrect, the most probable cause is the YTF Preselector. Reconnect W7 and W8 cables (or W31 and W34 cables).

The following High Band path items have been verified in the RF section:

- 4.8 GHz Calibrator signal power level from the A16 Reference Board
- 1st L.O. power level from the A14 L.O. Synthesizer
- Switch control logic from the A15 Front End Control Board to:
  - Input Attenuator A
  - Input Attenuator B
  - Low Band Switch
  - YTF Preselector
  - RF Front End Assembly
- Input Attenuator A
- Input Attenuator B
- Low Band Switch
- YTF Preselector

If all the power levels and biasing from the A15 Front End Control board measure correctly up to this point, the most probable cause would be the A13 Front End Assembly.

**NOTE**

High Band #2 RF signal path utilizes a high band mixer internal to the A13 RF Front End Assembly for RF input frequencies from 13.6 GHz to 26.5 GHz. Since all the control voltages and biasing were already fully tested, failures from 13.6 GHz - 26.5 GHz will most likely be caused by the A13 RF Front End Assembly. If the failure is amplitude related, proper adjustments such as frequency response and the YTF Preselector adjust should be performed first before changing the A13 RF Front End Assembly. Refer to **Chapter 11, "Block Diagrams."** for details.

---

## High Band Preamp (Option P08, P13, P26)

If any of the preamp options listed above is installed, the High Band preamp can be verified as follows:

View the 4.8 GHz calibrator signal on screen. Press **AMPTD, More, Internal Preamp, Full Range** to activate the preamp. The expected operation is the signal level will not change more than  $\pm 0.5$  dB and the noise floor will increase due to the fact the input attenuation was automatically increased.

If the amplitude error when switching the preamp on and off is greater than 0.5 dB, assure that any other internal alignment failures are resolved since the System Gain alignment must run before optimum performance is possible. The amplitude error could be caused by poor frequency response, and performing the high band frequency response adjustment (using the calibration software) will adjust the preamp on, high band path. Assure you have evaluated all causes including A15 Front End Controller switching problems, before you replace the Front End assembly.

## High Band Mixing Equations

For input signal frequencies from 3.6 GHz to 8.4 GHz and 13.6 GHz to 17 GHz:

$$RF = LO \times N - IF$$

$$IF = LO \times N - RF$$

$$LO \times N = IF + RF$$

where RF is the input signal at the signal analyzer

where N is the harmonic mixing mode:

$$N = 1 \text{ for } 3.5 \text{ GHz to } 8.4 \text{ GHz}$$

$$N = 2 \text{ for } 13.5 \text{ GHz to } 17 \text{ GHz}$$

For input signal frequencies above 8.4 GHz to 13.6 GHz and 17 GHz to 26.5 GHz:

$$RF = LO \times 2 \times N - IF$$

$$IF = LO \times 2 \times N - RF$$

$$LO \times 2 \times N = IF + RF$$

where RF is the input signal at the signal analyzer

where N is the harmonic mixing mode:

$$N = 1 \text{ for } 8.4 \text{ GHz to } 13.6 \text{ GHz}$$

$$N = 2 \text{ for } 17 \text{ GHz to } 26.5 \text{ GHz}$$

## Microwave Preselector Bypass (Option MPB)

Allows the YTF to be bypassed, improving amplitude accuracy.

Assure start frequency is 3.6 GHz or greater. Press **Amplitude, uW Path Control, uW Preselector Bypass**.

When the bypass switches Switch 1 and Switch 2 change state you will hear a click. Depending on the signal source connected, you may see many “signals” appear on screen because without pre-filtering, the analyzer will display image and multiple responses. The real input signal should not change amplitude when you switch the uW Preselector Bypass on and off.



## 5 Front End Control Troubleshooting

### What You Will Find in This Chapter

The following information is found in this chapter:

[A15 Front End Control Description on page 208](#)

[A15 Front End Control Assembly Troubleshooting on page 212](#)

## A15 Front End Control Description

### Purpose

The A15 Front End Controller board functionality can be broken down into (3) main categories

- 1. Provides switch control logic and bias voltages to the major RF front end assemblies in the analyzer.**
- 2. Contains on board circuitry providing various signal outputs to other locations within the analyzer.**
- 3. Provides control logic for various instrument options within the analyzer.**

These signals are routed to and from the A15 via ribbon cables, wiring harnesses and coaxial cables. The RF front end assemblies require the correct control logic and bias in order to function properly. If the voltages from the A15 are not correct, the RF input signals will most likely be displayed at an incorrect power level if they even get displayed at all.

Depending upon the options installed, one of two different A15 Front End Control board assemblies may be installed. The standard A15 Front End Control assembly ("FEC") can only control the high band preamplifier options (P08, P13 and P26) and the electronic attenuator option (EA3). The A15 Enhanced Front End Control assembly ("EFEC") can also control the IF Out options (CR3 and CRP), the microwave preselector bypass option (MPB), and provide the IF signal for analysis bandwidth options  $\geq 40$  MHz (B40, B85, B1A, and B1X).



**Standard RF Assemblies Controlled by the A15:**

- A9 Input Attenuator A (4 dB total)
- A10 Input Attenuator B (66 dB total)
- A11 Low Band Switch
- A12 YIG Tuned Filter
- A13 RF Front End Assembly

**A15 On Board Circuits:**

- RF Burst Trigger (When set to Relative Trigger or when center frequency is < 300 MHz.)
- YTF Tune Ramp
- Preselector Tune Out (Provides output voltage, not specified, reserved for future use)
- Mixer Bias
- Amplifier Bias
- Switch Control
- Sweep Ramp (reserved for future use)

Refer to **Table 5-1** for details regarding which options are supported by the two choices of A15 assemblies.

**Table 5-1 A15 Option Related Control**

Option	Description	Physical Location in Analyzer	A15 Support
P03	Preamplifier, 3.6 GHz	A15 to A13	FEC or EFEC
P08	Preamplifier, 8.4 GHz	A15 to A11	FEC or EFEC
P13	Preamplifier, 13.6 GHz	A15 to A11	FEC or EFEC
P26	Preamplifier, 26.5 GHz	A15 to A11	FEC or EFEC
CRP	Arbitrary IF Output	A15 to AUX IF OUT (rear panel)	EFEC
CR3	Second IF Output	A15 to AUX IF OUT (rear panel)	EFEC
MPB	Microwave Preselector Bypass	A15 to SW1 and SW2	EFEC
EA3	Electronic Attenuator, 3.6 GHz	A15 to A13	FEC or EFEC
B40	40 MHz Analysis Bandwidth	A15 to A3	EFEC
DP2	Digital Signal Processing & 2 GB Capture Memory	A15 to A3	EFEC
B85, B1A, or B1X	85, 125, and 160 MHz Analysis Bandwidths	A15 to A25	EFEC

Figure 5-1 A15 Front View, Physical Connectors (EFEC)

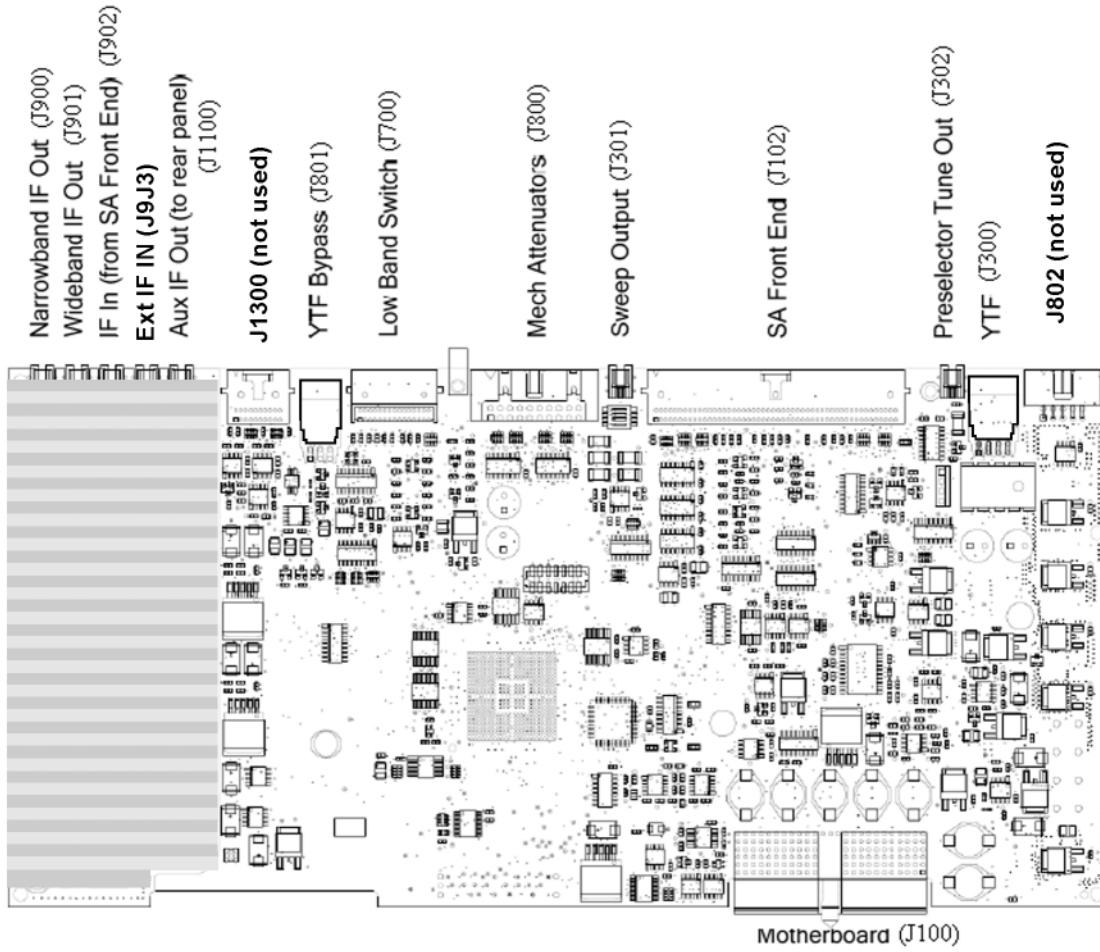
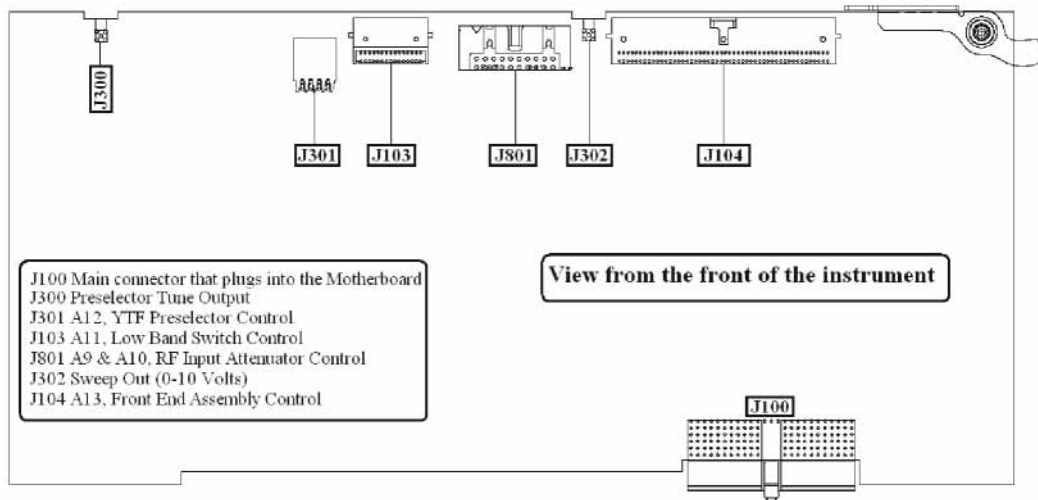


Figure 5-2 A15 Front View, Physical Connectors (standard FEC)



Front End Control Troubleshooting  
A15 Front End Control Description

The table below describes the connector location and the final destinations of the RF signal, switch control logic or bias voltage.

Table 5-2 A15 Connectors and Destinations

A15 Connector Designation		Description	Destination
FEC	EFEC		
N/A	J900	Narrowband I.F. Out	To A2
N/A	J901	Wideband I.F. Out	To A3 or A25
N/A	J902	322.5 MHz I.F. In	From A13
N/A	J1100	Aux I.F. Out	To Rear Panel
N/A	J1300	Switched I.F. Filter Out	Reserved for future use
N/A	J801	YTF Bypass Out	To SW1 & SW3 (Option MPB with Option 513 or 526)
J103	J700	Low Band Switch Logic Out	To A11
J801	J800	Mechanical Attenuator Logic Out	To A9 & A10
J302	J301	Sweep Out	Reserved for future use
J104	J102	R.F. Front End Logic Out	To A13
J300	J302	Preselector Tune Out	N/A (test point only)
J301	J300	YTF Bias Control Out	To A12
N/A	J802	Low Noise Bypass Switch Logic Out	Reserved for future use
J100	J100	Motherboard Connector	From A8

## A15 Front End Control Assembly Troubleshooting

Verifying the Front End Control Assembly requires the RF Front End Troubleshooting board E4410-60115 or kit number N9020-60005. The kit includes the troubleshooting board and associated interconnect cables. The troubleshooting board and cables will help verify the control logic from this assembly to Input Attenuator A, Input Attenuator B, Low Band Switch, YTF Preselector, (Optional) Low Band Preamplifier, (Optional) High Band Preamplifier, (Optional) Electronic Attenuator and the RF Front End Assembly. The control logic should be verified going to each assembly while the Front End Troubleshooting board is connected.

If the EFEC is installed, the remaining control voltages and RF signals can be measured directly with a voltmeter, oscilloscope, or functioning spectrum analyzer.

In order to verify the wide bandwidth I.F.'s and Aux I.F. output frequencies and power levels the following specialty cables and connector will be needed:

MMCX (m) to SMB (f) cable, p/n 8121-0655

MMCX (f) to MMCX (f) barrel. Huber & Suhner 31\_mmcx-50-0-1/111\_0E

Visit: <http://www.hubersuhner.com/de/ie70/hs-index>

Other standard cables and connectors need to be used to adapt to the voltmeter or the RF input of the functioning spectrum analyzer.

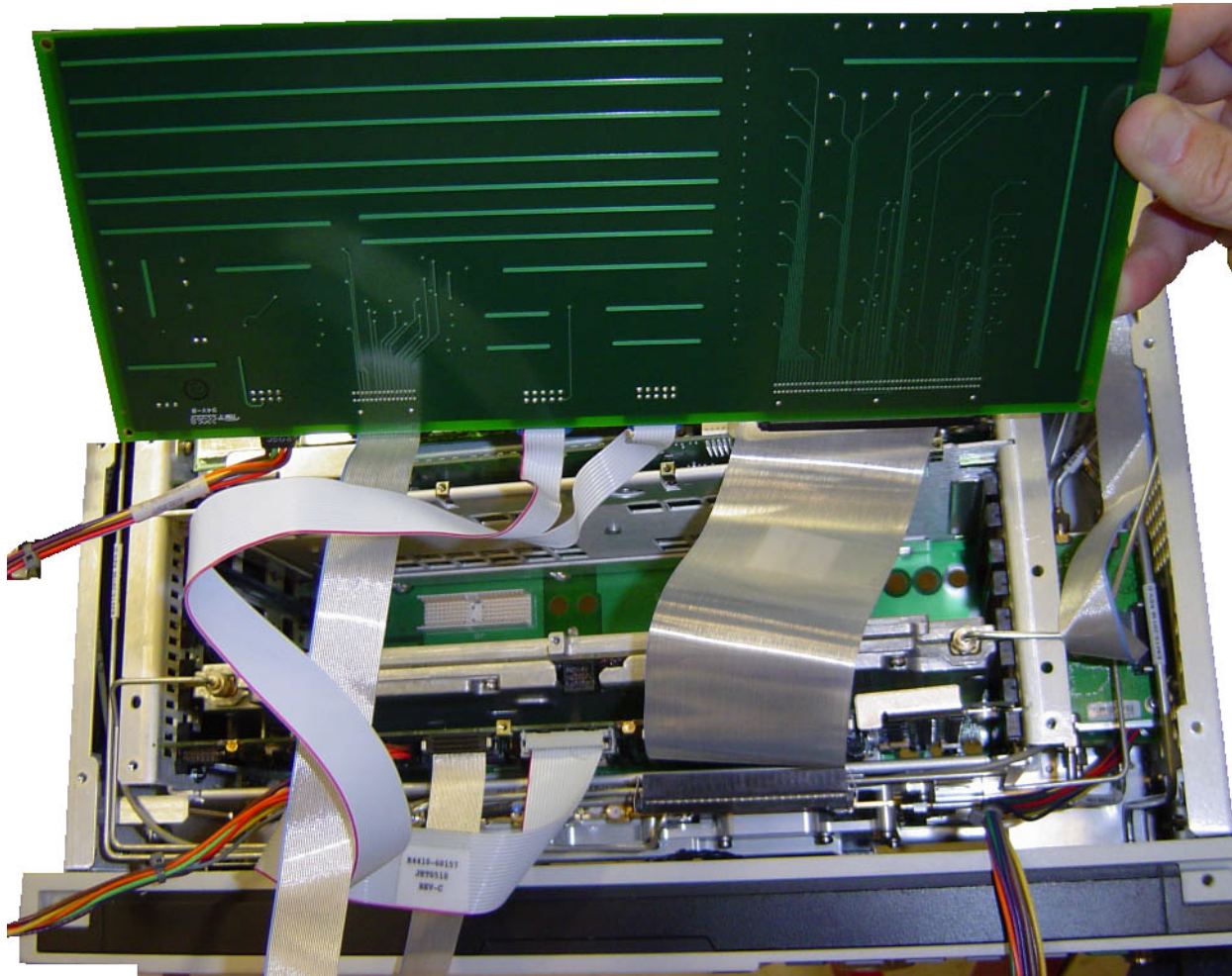
## Verifying Input Attenuator A, Input Attenuator B, Low Band Switch Logic and Power Supplies

**NOTE** Even though the YTF Preselector is not used in low band (input frequencies < 3.59 GHz), it is easy to test the switch control logic with the RF Front End Troubleshooting board installed in case there is a high band problem. The Low Band Preamplifier (Option P03), and Electronic Attenuator (Option EA3) logic should be tested if these options are installed in the analyzer.

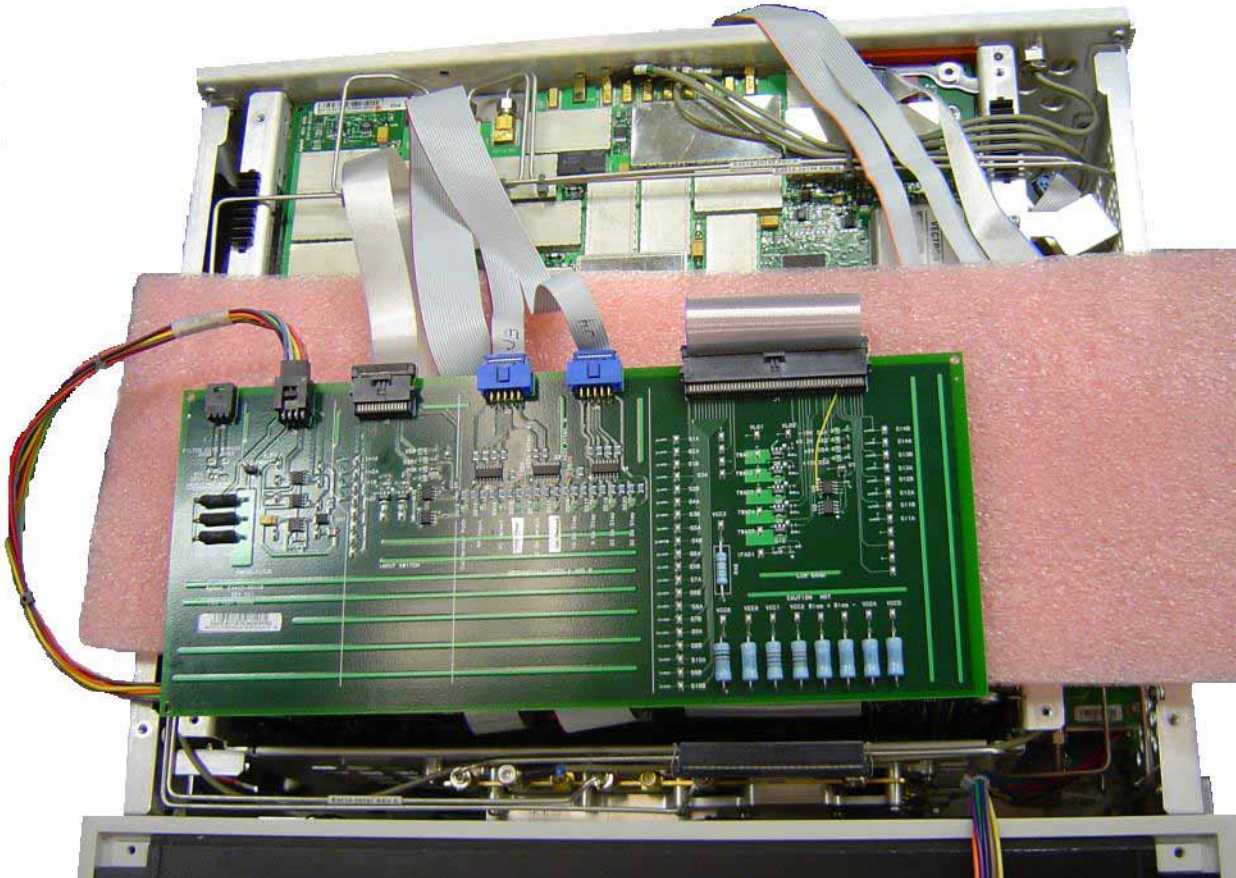
---

1. Turn off the instrument.
2. Connect the E4410-60115 RF Front End Troubleshooting board to the A15 Front End Control Assembly as shown in [Figure 5-3](#) and [Figure 5-4](#).

**Figure 5-3** RF Front End Troubleshooting Board



**Figure 5-4** RF Front End Troubleshooting Board



3. Turn the instrument on and allow it to complete its full boot up process to the signal analyzer application.
4. Turn Auto Align off by pressing **System, Alignments, Auto Align, Off** on the analyzer.

**CAUTION**

Resistors on the test board can get very hot. Handle with care.

---

## Power Supply Verification

Looking at the test board, verify power supply green LED's DS5, DS6, DS7 and DS8 located under the J2 connector are turned on. Additionally red LED's DS9 and DS10 should also be on. The power supply voltages are listed in the table below.

Table 5-3 Power Supply Voltages

LED	Power Supply
DS5	+15 VDC
DS6	+9.0 VDC
DS7	+5.2 VDC
DS8	-15 VDC
DS9	+25 VDC (for Attenuator A)
DS10	+25 VDC (for Attenuator B)

If any of the power supply LED's are not turned on, see [Chapter 2, “Boot Up and Initialization Troubleshooting”](#).

## Input Attenuator A Control Logic Verification

Press **AMPTD, Attenuation 0 dB** on the analyzer.

Attenuation LED's DS15-20 on the test board should be off.

When the input attenuation is changed from 0 dB to 2 dB, the 2 dB Step LED DS15 should illuminate. When the input attenuation is changed from 2 dB to 4 dB, DS15 and DS16 should be illuminated as per [Table 5-4](#).

Table 5-4 Input Attenuator A LED's

Attenuator Setting (dB)	DS15	DS16
0	OFF	OFF
2	ON	OFF
4	ON	ON

If this is incorrect, the most probable cause is the A15, Front End Control board.

The analyzer default setting for RF Coupling is AC mode. Verify the AC Select LED DS14 is illuminated at this time. Press **Input/Output, RF Input, RF Coupling, AC/DC** to DC on the analyzer. DS14 should turn off and DS11, DC Select LED should illuminate. Switch the RF Coupling back to AC. If the LED's do not illuminate correctly, the most probable cause is the A15 Front End Control Assembly.

## Input Attenuator B Control Logic Verification

Press **AMPTD, Attenuation 6 dB** on the analyzer and verify the 6 dB Step LED DS17 is illuminated. Change to the input attenuation settings found in **Table 5-5** and verify the proper LED's illuminate on the Front End Troubleshooting board according to **Table 5-5**.

Table 5-5 Input Attenuator B LED's

Attenuator Setting (dB)	DS20 30 dB Step LED	DS19 20 dB Step LED	DS18 10 dB Step LED	DS17 6 dB Step LED
6	OFF	OFF	OFF	ON
10	OFF	OFF	ON	OFF
16	OFF	OFF	ON	ON
20	OFF	ON	OFF	OFF
30	ON	OFF	OFF	OFF
40	ON	OFF	ON	OFF
50	ON	ON	OFF	OFF
60	ON	ON	ON	OFF
66	ON	ON	ON	ON

If the LED's illuminate correctly, the switch control logic for the input attenuators from the A15 Front End Control Assembly is correct. If the LED's are not illuminating as expected, the most probable cause is the A15 Front End Control Assembly.

Set the input attenuator back to 10 dB by pressing **AMPTD, Attenuation, 10 dB** on the analyzer.

## Low Band Switch Control Logic Verification (all except Option 503)

Press **Mode Preset** on the analyzer. Press **FREQ, 50 MHz, SPAN, 2 MHz** on the analyzer. Make sure the auto alignments are turned off by pressing **System, Alignments, Auto Align, Off**. Connect the voltmeter positive lead to test point listed in the table below and the negative lead to the instrument chassis. These test points are located under the J2 connector. Verify the voltages in **Table 5-6**.

Table 5-6

Test Board Test Point	Voltage (VDC)
In1A	-9.90



Table 5-6

Test Board Test Point	Voltage (VDC)
In2A	-9.90
In1B	+10.0
In2B	+10.0

Press **FREQ, 5 GHz** on the analyzer. Verify the voltages in [Table 5-7](#).

Table 5-7

Test Board Test Point	Voltage (VDC)
In1A	+10.0
In2A	-9.90
In1B	-10.0
In2B	+10.0

If the voltages are not correct, the most probable cause is the A15 Front End Control board.

You do not need the RF front end troubleshooting board to test out the remaining front end hardware components. At this point it is advisable to shutdown the analyzer and disconnect the test board and cables. Be sure to reconnect the Low Band switch ribbon cable and the input attenuator ribbon that were originally plugged into the Front End Control board before testing the input attenuator and low band switch logic.

## Preselector Tune Output

The Presel Tune connector A15J300 (FEC) or A15J302 (EFEC) is a test point used to verify the internal A12, YIG Tuned Filter drive voltage variations with center frequency. The YTF is used in the high band path (3.6 GHz to the analyzer's maximum frequency). Connect Presel Tune to a voltmeter. Use the MMCX (m) to SMB (f) to connect to Presel Tune on the A15 board and appropriate adaptors to connect to the voltmeter. Refer to **Figure 5-1** or **Figure 5-2** or Presel Tune location. You may also need a Banana plug to BNC (f) adapter, part number E9637A for the Voltmeter. The preselector tune output voltage can be measured to verify this portion of the A15 is functioning.

Press **System, Alignments, Auto Align, Off** on the analyzer once it has fully booted to the spectrum analyzer application. Press **Span, Zero Span** on the analyzer. The preselector tune output voltage in high band should change when the center frequency of the analyzer is changed.

**NOTE** Preselector tune output measurements are not valid for Option 503, 3 GHz frequency range.

---

Table 5-8 Preselector Tune Output Voltages

Center Frequency (GHz)	~ Tune Voltage (VDC)	Valid Frequency Range Option
5.0	1.6	508, 513, 526
10.0	3.3	513, 526
15.0	4.85	526
20.0	6.5	526
26.0	8.45	526

Even if the voltages listed in the table are correct it does not guarantee the proper control current is getting to the YTF. There is not a convenient way to measure the control current, so if a high band issue is suspect it is recommended that the A15 is changed out first before changing the YTF since the A15 board has easy access.

To further test the YTF control current, select Amps on the DVM and place the positive lead of the DVM on one of the YTF Coil Current P8 pins and the other DVM lead to the other Coil Current pin.

**NOTE** In order to measure the control current correctly, press **Single** on the analyzer in between each measurement.

---

If any of the preselector control currents do not match the levels shown in **Figure 5-9**, the most probable causes are a misaligned YTF or the A15 Front End Control Assembly. Perform the YTF characterization (press **System, Alignments, More, Advanced, Characterize Preselector**) and re-check the control current at various center frequencies.

Table 5-9 YTF Tune Current

Center Frequency (GHz)	Control Current (ma)	Tolerance (ma)
5.0	106	± 20
10	215	± 25
15	324	± 30
20	430	± 40
26	560	± 50

**NOTE** Tolerances should be used as a guideline. The true test is whether or not the analyzer will function and meet published specification.

### Front End Assembly Control Logic Verification

Since the RF Front End Troubleshooting board is connected, now is a good time to test out the remaining control circuits from the A15 Front End Control Assembly.

Table 5-10 Front End Control Logic

Test Point	Description	Instrument Settings	Voltage (VDC)	Tolerance (VDC)
S2A	Sets switch for Low Band/preamp path	CF 50 MHz preamp on	+9.67	±0.5
S2B	Sets switch for Low Band/preamp path	CF 50 MHz preamp on	+9.83	±0.5
S3A	Sets E-atten to 5 dB preamps off	E-atten = 5 dB	+9.67	±0.5
S3B	Sets E-atten to 5 dB preamps off	E-atten = 5 dB	+9.83	±0.5
S4A	Sets E-atten to 10 dB preamps off	E-atten = 10 dB	+9.67	±0.5
S4B	Sets E-atten to 10 dB preamps off	E-atten = 10 dB	+9.83	±0.5
S5A	Sets E-atten to 2 dB preamps off	E-atten = 2 dB	+9.67	±0.5

Front End Control Troubleshooting  
A15 Front End Control Assembly Troubleshooting

**Table 5-10 Front End Control Logic**

Test Point	Description	Instrument Settings	Voltage (VDC)	Tolerance (VDC)
S5B	Sets E-atten to 2 dB preamps off	E-atten = 2 dB	+9.83	±0.5
S6A	Sets E-atten to 1 dB preamps off	E-atten = 1 dB	+9.67	±0.5
S6B	Sets E-atten to 1 dB preamps off	E-atten = 1 dB	+9.83	±0.5
S7A	Sets E-atten to 2 dB preamps off	E-atten = 2 dB	+9.67	±0.5
S7B	Sets E-atten to 2 dB preamps off	E-atten = 2 dB	+9.83	±0.5
S8A	Sets E-atten to 20 dB preamps off	E-atten = 20 dB	+9.67	±0.5
S8B	Sets E-atten to 20 dB preamps off	E-atten = 20 dB	+9.83	±0.5
S9A	Controls in & out to low band preamps off	E-atten = off	+9.83	±0.5
S9B	Controls in & out to low band preamps off	E-atten = off	+9.67	±0.5
S11A	Sets path for 1st or 2nd L.O.	CF 1 GHz	+9.67	±0.5
S11B	Sets path for 1st or 2nd L.O.	CF 1 GHz	+9.83	±0.5
S12A	Sets path for L.O. normal or x2 for band 4	CF 1 GHz	+9.83	±0.5
S12B	Sets path for L.O. normal or x2 for band 4	CF 1 GHz	+9.67	±0.5
S13A	Sets path for L.O. to either of the high band mixers and L.O. output	CF 5 GHz CF 20 GHz	-9.67 +9.67	±0.5
S13B	Sets path for L.O. to either of the high band mixers and L.O. output	CF 5 GHz CF 20 GHz	+9.83 -9.83	±0.5
S14A	Sets path to either band 1 & 2 mixer or band 3 & 4 mixer	CF 5 GHz CF 20 GHz	-9.83 +9.83	±0.5
S14B	Sets path to either band 1 & 2 mixer or band 3 & 4 mixer	CF 5 GHz CF 20 GHz	+9.67 -9.67	±0.5
VCC1	Voltage always on		4.8	±0.5
VCC2	Voltage always on		4.8	±0.5
VCC3	Voltage always on		7.85	±0.5
VCC4	Voltage always on		5.0	±0.5
VCC5	Voltage always on		5.0	±0.5
TWAD1	Amplifier bias to A13 RF Front End Assembly		6.0	±0.5
TWAD2	Amplifier bias to A13 RF Front End Assembly		6.0	±0.5

Table 5-10 Front End Control Logic

Test Point	Description	Instrument Settings	Voltage (VDC)	Tolerance (VDC)
TWAD3	Amplifier bias to A13 RF Front End Assembly		6.0	±0.5
TWAD4	Amplifier bias to A13 RF Front End Assembly		6.0	±0.5
TWAD5	Amplifier bias to A13 RF Front End Assembly		6.0	±0.5

**NOTE** Tolerances should be used as a guideline.

If any of the voltages measured are incorrect, the most probable cause is the A15 Front End Control Assembly. Once the switch control logic has been verified, turn off the instrument. Disconnect the RF Front End Troubleshooting board cables, and reconnect the analyzer cables to the A15 Front End Control Assembly. Turn the instrument on and allow it to complete its full boot up process to Spectrum Analyzer mode.

### Verifying SW1 and SW2 (Option MPB only)

SW1 and SW2 can be verified three different ways:

- “Click” Test
- Oscilloscope
- R.F. Signal Tracing

#### “Click” Test

This test changes between two different path modes. When this is done a distinct “click” noise from SW1 and SW2 can be heard. Since both switches switch at the same time, it is difficult to decipher if one is switching and the other is not.

Press **Mode, Preset** on the analyzer. Press **FREQ, 5 GHz, SPAN, 1 MHz, AMPTD, More 1 of 2, uW Path Ctrl.** Standard Path is the default. Select uW Preselector Bypass and you should hear a distinct “click” noise if the control logic from the A15 Front End Control board is getting to SW1 and SW2.

## Oscilloscope Test

Measurements can be made to verify the correct logic is getting to SW1 and SW2 from the A15. In order to perform this measurement, the outer cover and chassis RF bracket on the right hand side of the instrument must be removed. Refer to **Chapter 14, "Assembly Replacement Procedures"** for the removal procedures.

**Figure 5-5, Figure 5-6, and Figure 5-7** illustrate the measurement location where the oscilloscope probe should be used to measure the logic. There are two connector bodies (**1**) with three wires each (green, black and purple). One connector goes to SW1 and the other to SW2, 3 wires to each switch.

Figure 5-5 SW1 and SW2 Connector Location

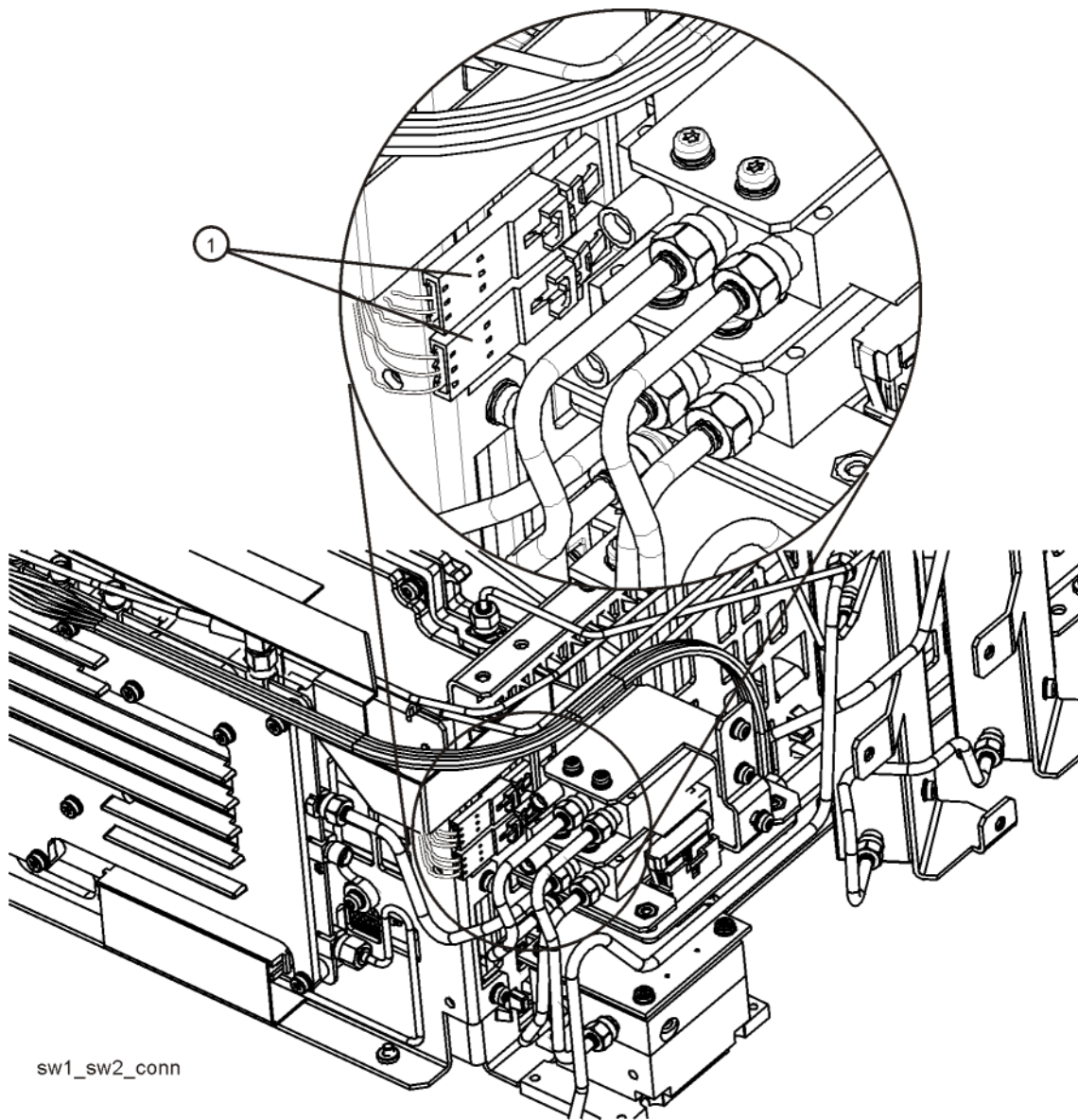
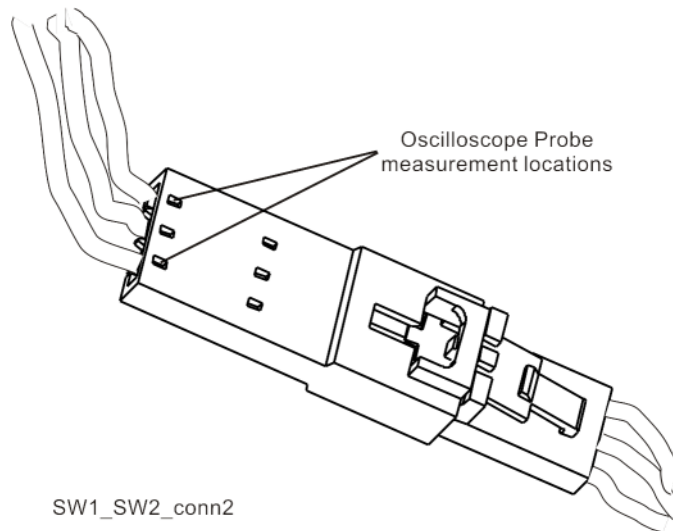
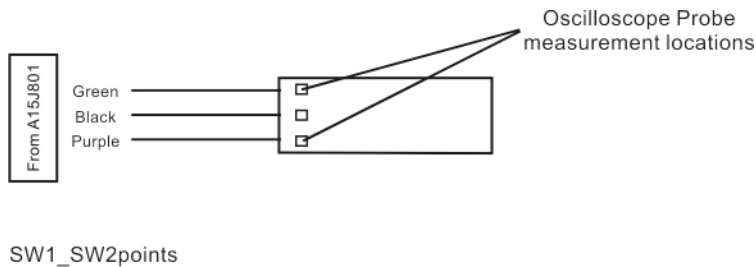


Figure 5-6 Connector Close-up



To verify the control logic, press **Mode Preset** on the analyzer. Press **FREQ, 5 GHz, SPAN, 1 MHz, AMPTD, More 1 of 2, uW Path Ctrl.** Standard Path is selected by default. Carefully place the scope probe tip on the conductive portion where the green wire goes into the connector, see [Figure 5-7](#).

Figure 5-7 Connector Detail



The voltage should be ~21.5 VDC steady state at this point. When you switch from Standard Path to uW Preselector Bypass, you should see a negative going pulse to 0 VDC on the oscilloscope for ~15 mS before the voltage returns to ~21.5 VDC steady state. The oscilloscope triggering may need to be adjusted to see the negative going pulse. This can be tested on both connectors that contain the green wire.

Monitor the purple wires on each connector, one at a time. The purple wire starts at ~21.5 VDC. When switching from uW Preselector Bypass to Standard Path, you should see a negative going pulse to 0 VDC on the oscilloscope for ~15 mS before the voltage returns to ~21.5 VDC steady state.

If both the green wires and the purple wires measure this pulse correctly, the control logic from the A15, Front End Controller board is operating correctly.

The black wire is ground.

### RF Signal Tracing

Refer to [Chapter 4, “RF Section Troubleshooting”](#) for this method of troubleshooting if you are unable to use an oscilloscope

### Verifying Narrowband IF Out (A15J900)

The outer cover and top shield need to be removed to verify A15J900 I.F. output to the A2 Analog IF assembly. Refer to [Chapter 14, “Assembly Replacement Procedures”](#) for the removal procedure. Press **Mode, Spectrum Analyzer, Mode Preset** on the analyzer. Press **Input/Output, RF Calibrator, 50 MHz, Freq, 50 MHz, Span, 0 Hz, Amptd, Attenuation, 10 dB, Amptd, More 1 of 2, Internal Preamp Off, System, Alignments, Auto Align, Off**. Disconnect the cable marked J900 that plugs into the top of the A15, Front End Controller board and connect a functioning spectrum analyzer where the cable was plugged in. J900's output should be 322.5 MHz at ~-28 dBm on the functioning spectrum analyzer if the Front End Controller board is switching this level correctly. If -28 dBm is not being measured correctly, remove the cable labeled J902 from the Front End Controller board and measure the output of that cable. This should also measure 322.5 MHz at ~-28 dBm. If the output of the J902 cable measures correctly and yet the output of J900 is incorrect, the most probable cause is the A15, Front End Controller board.

Reconnect all cables to their correct location when finished with the measurements.

#### IMPORTANT

When plugging in an mmcx connector, a distinct “snap” should be heard when the cable is seated correctly.

---



### Verifying Wideband IF Out (A15J901, Options B40, B85, B1A, or B1X)

The outer cover and top shield need to be removed to verify A15J901 output. Refer to **Chapter 14, "Assembly Replacement Procedures"** for the removal procedure. Press **Mode, IQ Analyzer (Basic), Mode Preset** on the analyzer. Press **Input/Output, RF Calibrator, 50 MHz, Freq, 50 MHz, Amptd, Attenuation, 10 dB, Amptd, More 1 of 2, Internal Preamp Off, System, Alignments, Auto Align, Off**. Disconnect the cable marked J901 that plugs into the Front End Controller board and connect a functioning spectrum analyzer where the cable was plugged in. J901's I.F. output will vary depending on the I.F. path that is chosen. Press **Mode Setup, IF Path** and select **40 MHz**. If the switch path is working correctly in the A15 Front End Controller board, the functioning spectrum analyzer should measure 250 MHz at approximately -30 dBm.

If Options B85, B1A, or B1X are also present, press **Mode Setup, IF Path** and select either **85 MHz, 125 MHz, or 140 MHz** (whichever is present). If the switch path is working correctly in the A15 Front End Controller board, the functioning spectrum analyzer should measure 300 MHz at approximately -30 dBm.

In order for these I.F. levels to measure correctly, the I.F. input at A15J902 must be correct. Refer to **Chapter 4, "RF Section Troubleshooting"**. Reconnect all cables to their correct location when finished.

### Verifying Aux IF Out, Rear Panel (Option CR3, CRP only)

The Aux I.F. output connector on the rear panel is installed on all analyzers equipped with the EFEC version of the A15, however the actual Aux I.F. output frequency will vary depending on the options installed. These options are all enabled with a license key. The first step in verifying the Aux I.F. output is the make sure the option is licensed by pressing **System, Show, System** on the analyzer and make sure the option identifies itself in the table.

The I.F. switch path and frequency generation occurs on the A15, Front End Controller board. This troubleshooting procedure provides the instrument setups to verify options CR3 and CRP. Test the Aux I.F. output based on the options installed in the analyzer.

### Standard Analyzer

No test to perform.

### Verifying Option CR3

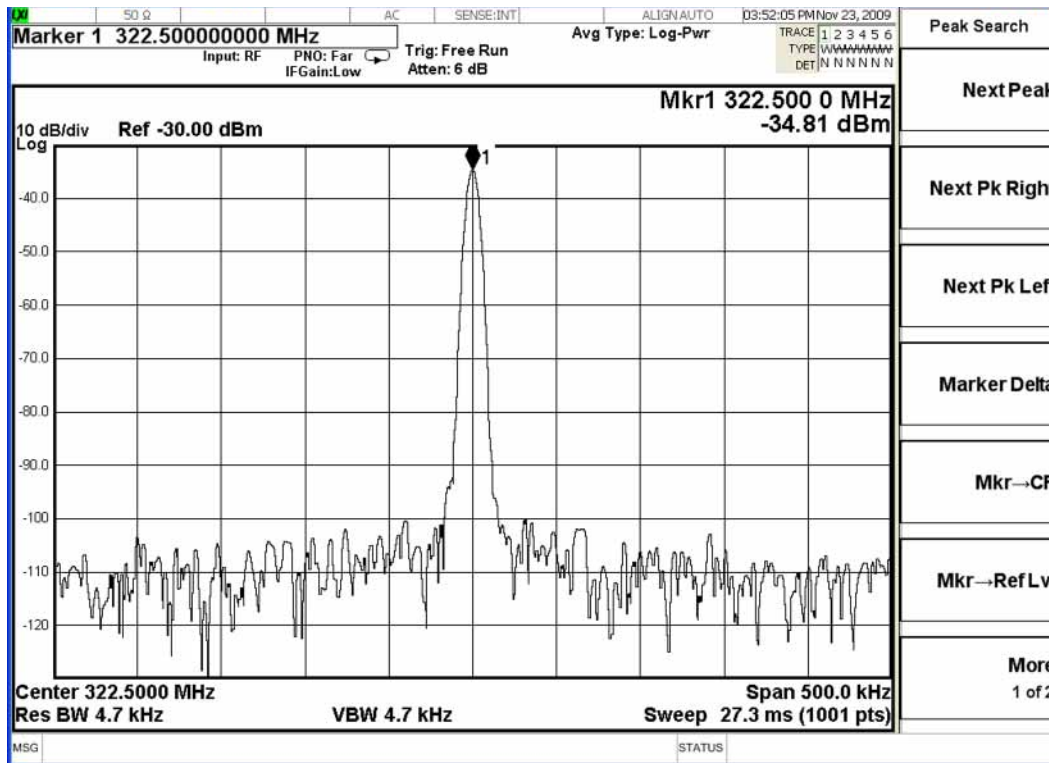
Press the following keys on the analyzer:

**Mode, Spectrum Analyzer, Mode Preset, Input/Output, RF Calibrator, 50 MHz, Freq, 50 MHz, Span, 0 Hz, System, Alignments, Auto Align, Off, Input/Output, More 1 of 2, Output Config, Aux IF Out, Second IF**

Connect the Aux I.F. Output on the rear panel to the RF Input of a functioning spectrum analyzer. If the A15 Front End Controller is switching the I.F. correctly, you should measure 322.5 MHz at  $-35 \text{ dBm} \pm 3 \text{ dB}$  as per [Figure 5-8](#).

Figure 5-8

322.5 MHz



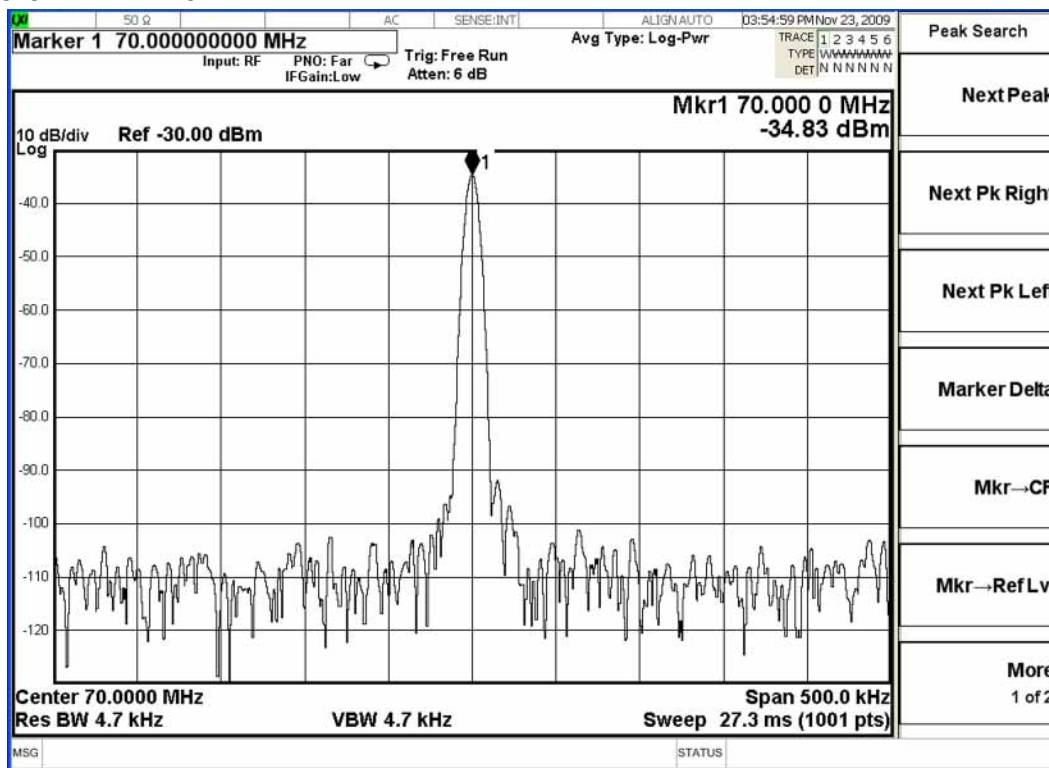
## Verifying Option CRP

Press the following keys on the analyzer:

**Mode, Spectrum Analyzer, Mode Preset, Input/Output, RF Calibrator, 50 MHz, Freq, 50 MHz, Span, 0 Hz, System, Alignments, Auto Align, Off, Input/Output, More 1 of 2, Output Config, Aux IF Out, Arbitrary IF.**

The default is 70 MHz, which can be measured on a functioning spectrum analyzer. The amplitude level should be  $-35 \text{ dBm} \pm 3 \text{ dB}$  as per [Figure 5-9](#). With the Arbitrary IF as the active function, you can vary the I.F. from 10 MHz to 70 MHz in 500 kHz steps and measure the Aux IF output. The amplitude level should remain fairly flat across the entire arbitrary IF output range.

Figure 5-9 70 MHz



Front End Control Troubleshooting  
A15 Front End Control Assembly Troubleshooting

## 6 Analog/Digital IF Troubleshooting

### What You Will Find in This Chapter

The following information is presented in this chapter:

1. Theory of operation of the IF section.
2. Isolating the cause of a hardware problem by verifying the functionality of assemblies in the IF section signal path.

The analyzer can have one of three sets of IF hardware installed. The standard 25 MHz BW IF hardware supports analysis bandwidths up to 25 MHz. The optional 40 MHz BW IF hardware supports analysis bandwidths up to 40 MHz. The 40 MHz IF hardware is installed if any of the following options are installed:

- B40, 40 MHz Analysis Bandwidth
- MPB, Microwave Preselector Bypass
- DP2, Digital Processor & 2 GB Capture Memory

The  $\geq 85$  MHz BW IF hardware supports analysis bandwidths up to 160 MHz. It also includes the 40 MHz BW IF hardware.

#### NOTE

The following sections provide for each assembly a description of how the assembly works and then gives information to help you troubleshoot the assembly. Each description explains the purpose of the assembly, describes the main components, and lists external connections to the assembly.

---

This following sections are found in this chapter:

#### 25 MHz BW IF Section

- A2 Analog I.F. Assembly Description on page 232
- A2 Analog I.F. Assembly Theory of Operation on page 233
- A2 Analog I.F. Troubleshooting on page 236
- A3 Digital I.F. Assembly Description on page 243
- A3 Digital I.F. Assembly Theory of Operation on page 244
- A3 Digital I.F. Troubleshooting on page 246

#### 40 MHz BW IF Section

Analog/Digital IF Troubleshooting  
What You Will Find in This Chapter

A2 Analog IF Assembly Description on page 251  
A2 Analog IF Assembly Theory of Operation on page 252  
A2 Analog IF Troubleshooting on page 255  
A3 Digital IF Assembly Description on page 262  
A3 Digital IF Assembly Theory of Operation on page 263  
A3 Digital IF Troubleshooting on page 265

≥ 85 MHz BW IF Section

A25 Wideband Analog IF Assembly Description on page 273

A25 Wideband Analog IF Assembly Theory of Operation on page 273

A25 Wideband Troubleshooting on page 275

A26 140 MHz Wideband Digital IF Troubleshooting on page 278

## 25 MHz BW IF Section

### A2 Analog I.F. Assembly Description

The analyzer's RF input signal is down converted to a 322.5 MHz intermediate frequency in the A13 RF Front End Assembly. This 322.5 MHz signal is the input to the A2 Analog I.F. Assembly. The Analog I.F. down converts the 322.5 MHz signal to a final 22.5 MHz intermediate frequency. In order to obtain optimal dynamic range and minimize unwanted spurious signals, this signal is filtered, amplified and attenuated throughout this assembly. The final 22.5 MHz signal goes through a series of variable band pass filters each having a specific bandwidth. Three things determine the signal path and which filters are chosen:

- Instrument resolution bandwidth (RBW) setting
- Application used
- Mode applied

This assembly contains the burst carrier trigger circuitry for performing mobile communication measurements. The output of the assembly is a filtered 22.5 MHz signal that goes to the ADC on the A3 Digital I.F. Assembly.

#### **Inputs to the A2**

322.5 MHz signal (from either the A13 RF Front End Assembly or the A15 Front End Control Assembly)

LO Input (300 MHz signal from A16 Reference Assembly)

22.5 MHz Cal Comb Signal (from the A3 Digital I.F. Assembly)

#### **Outputs from the A2**

22.5 MHz signal (to A3 Digital I.F. Assembly)

RF Trigger Detector (to A3 Digital I.F. Assembly)



## A2 Analog I.F. Assembly Theory of Operation

**NOTE** Refer to **Chapter 11, “Block Diagrams”**.

---

### **Input Switch and Filter**

A 322.5 MHz input signal is received from the A13 RF Front End Assembly. For analyzers equipped with Option CR3 and/or CRP, the 322.5 MHz input signal is routed from the A13 Front End Assembly to the IF MUX on the A15 Front End Control Assembly and from there to the A2 Analog IF Assembly. The signal then goes through a band pass filter centered at 322.5 MHz with a 25 MHz bandwidth. A cal comb signal can be automatically switched in at the input of the assembly to calibrate the prefilters.

### **Step Attenuator and Amplifier**

A 1 dB step attenuator follows to compensate for band gain differences. The signal then goes through a high-dynamic range amplifier.

### **Image Filters**

One of three different filter paths will be selected automatically, depending on the analyzer mode.

- The through path is selected in IQ Analyzer Mode and wide-band demod.
- The 12 MHz ceramic bandpass filter is used for normal Signal Analyzer swept and FFT operation.
- The 300 kHz Surface Acoustic Wave (SAW) is used for ACP modes.

### **Mixer**

There are two mixers that reside on this assembly. The first mixer is used to down convert the 322.5 MHz input to the final 22.5 MHz I.F. The other mixer is described in the I.F. Comb Cal section.

### **3rd LO**

The 300 MHz 3rd L.O. signal comes from the A16 Reference Assembly and conditions it for use as an L.O. in the two mixers that reside on this assembly. The third L.O. power is ~ +10 dBm to optimize the conversion efficiency of the first mixer.

### **I.F. Comb Cal**

The 2nd mixer is used to mix the 300 MHz L.O. from the Reference Assembly with the 22.5 MHz cal comb signal from the A3 Digital I.F. to allow calibration of the prefilters and overall passband phase and amplitude. The signal is attenuated by 20 dB if necessary. A limiter is used to reduce amplitude variation effects.

### Post Down Conversion Amplification and Prefiltering

The 22.5 MHz I.F. goes through a fixed gain amplifier. Then prefilters are switched in and out. The signal then goes through a variable gain amplifier.

The prefilters provide four single-pole filters to limit the bandwidth of the signal reaching the ADC on the A3 Digital I.F. assembly. There are five different signal paths for the 22.5 MHz I.F. when using Signal Analyzer swept mode:

1. LC wide
2. LC narrow
3. Crystal wide
4. Crystal narrow
5. Through path

The LC wide signal path is used when the analyzer Res BW setting is 180 kHz to 390 kHz.

The LC narrow signal path is used when the analyzer Res BW setting is 30 kHz to 160 kHz.

The Crystal wide signal path is used when the analyzer Res BW setting is 4.3 kHz to 27 kHz.

The Crystal narrow signal path is used when the analyzer Res BW setting is < 3.9 kHz.

The through path is used when the analyzer Res BW setting is 430 kHz and greater in analyzer swept mode.

#### NOTE

In IQ Analyzer mode or in Spectrum Analyzer mode with Sweep Type of FFT, the analyzer span setting determines the pre-filter settings.

---

### **Anti-Alias Filter and Final Amplifier**

The anti-alias filters attenuate unwanted out-of-band noise and distortion products. The first anti-alias filter is centered at 22.5 MHz and is 25 MHz wide.

The signal can bypass the second anti-alias filter when the analyzer utilizes either the IQ Analyzer swept, or wide-band demod.

The through path is selected when the image filter is in the 25 MHz mode (for IQ Analyzer swept and wide-band demod)

In all other cases the signal will pass through the second 12 MHz anti-alias filter.

The step gain block provides an additional switchable 10 dB gain to overcome the ADC noise floor and provide an additional 2 dB of analyzer sensitivity.

### **Burst Carrier Trigger**

The Burst Carrier Trigger detector provides a binary signal to be used as a trigger based on the presence of an RF input signal or not. The variable gain amplifiers drive a detector and its output drives a comparator which generates the trigger signal.

## A2 Analog I.F. Troubleshooting

There are three steps to verify the A2 Analog I.F. Assembly.

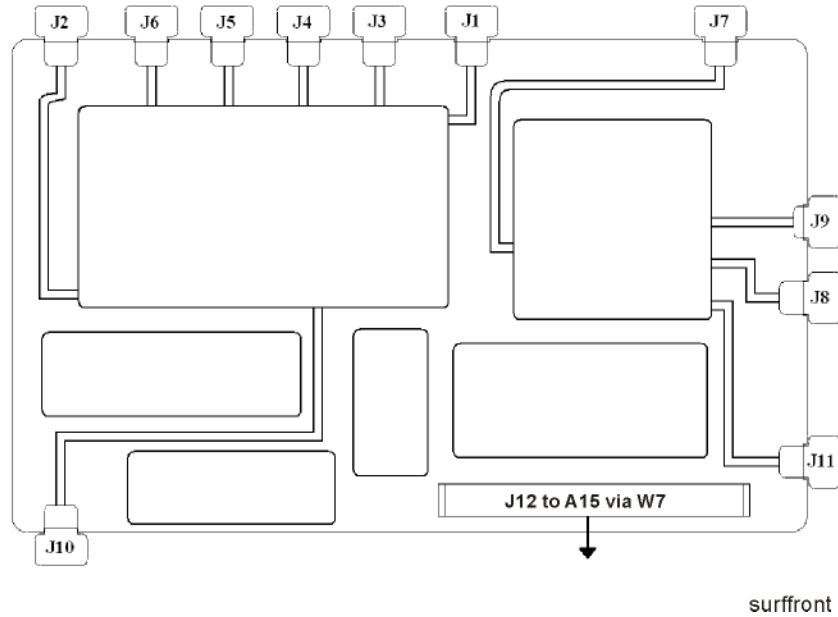
- Measure the input power and frequency accuracy of the 322.5 MHz signal (from the A13 RF Front End assembly or the A15 Front End Control Assembly).
- Measure the output power and frequency accuracy of the 22.5 MHz signal (to the A3 Digital I.F. Assembly)
- Measure the 300 MHz input LO signal (from the A16 Reference Assembly)

### Verifying the 322.5 MHz Input Power

1. Turn the instrument off.
2. Remove instrument cover. Refer to [Chapter 14, “Assembly Replacement Procedures”](#) in this service guide.
3. Turn on the N9020A Signal Analyzer and wait for the instrument to complete the boot up process.
4. Press **System, Alignments, Auto Align, Off**.
5. Press **Input/Output, RF calibrator, 50 MHz**.
6. Verify the 50 MHz signal is at –25 dBm on the analyzer display by pressing **FREQ, 50 MHz, SPAN, 1 MHz, Peak Search** on the N9020A. The marker readout should be 50 MHz at –25 dBm ± 3 dBm. If this reference signal is measuring incorrectly, see [Chapter 4, “RF Section Troubleshooting”](#) in this service guide.
7. To continue verifying press **SPAN, Zero Span**. Verify the input attenuator on the N9020A is set to 10 dB. Look near the top of the display near the center and verify that **Atten: 10 dB** is visible. If needed change the input attenuator by pressing **AMPTD, Attenuation, 10 dB** on the analyzer.

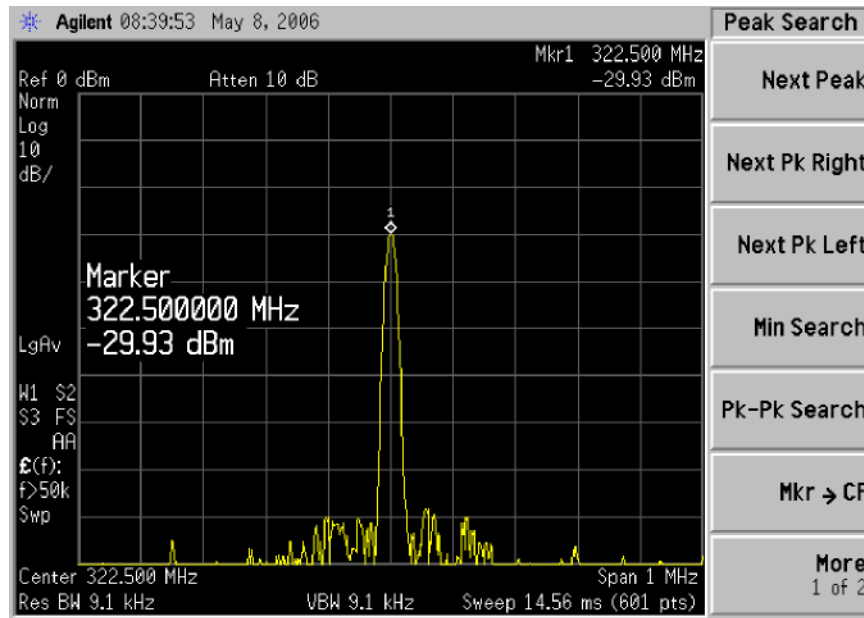
- Carefully disconnect the W15 or W36 cable at A13J7 as shown in **Figure 6-1**.

**Figure 6-1** A13 RF Front End Assembly - RF/Microwave Instruments



- Connect A13J7 to a functioning spectrum analyzer using the appropriate SMA connectors and cables.
- Press **Freq, 322.5 MHz, Span, 1 MHz, Peak Search** on the functioning spectrum analyzer
- The analyzer should read 322.5 MHz at  $-30 \text{ dBm} \pm 3 \text{ dBm}$  as shown in **Figure 6-2**.

**Figure 6-2** A13 322.5 MHz Output



**NOTE** If the 322.5 MHz signal is not measuring the correct power level, refer to [Chapter 4, “RF Section Troubleshooting”](#) in this service guide.

---

Reconnect W15 at A13J7.

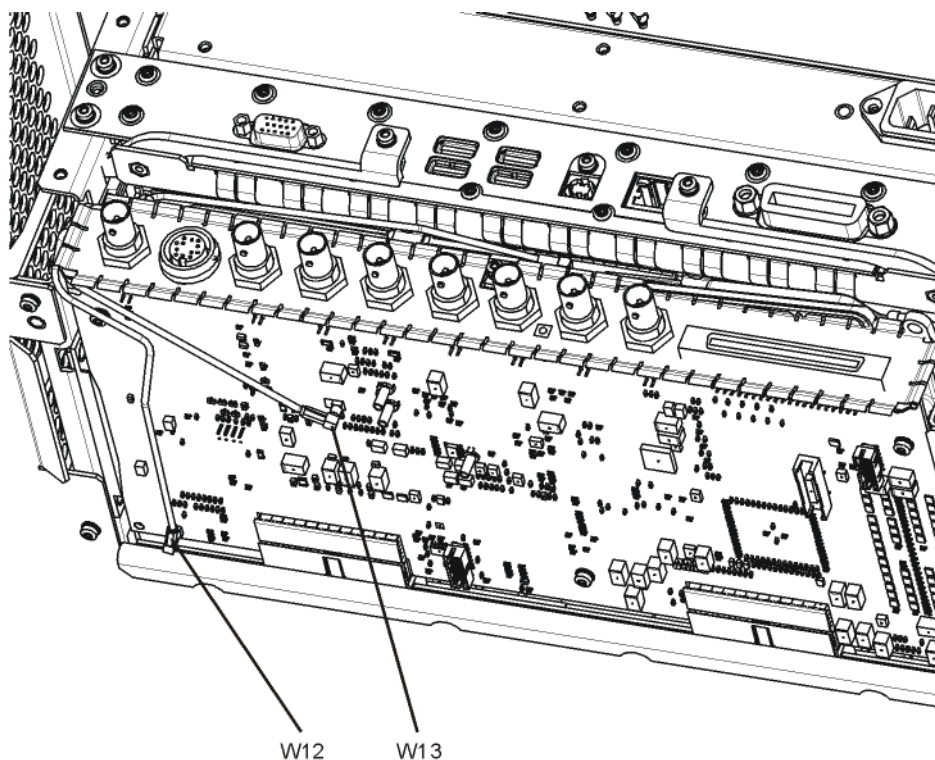
**IMPORTANT** Measuring at this location is for convenience. The 322.5 MHz signal is an output at A13J7. Since the W15 cable connects from this output to the input of the Analog I.F. assembly at A2J100, the small coaxial cable has not been tested at this point. If the analyzer is equipped with either Option CR3 and/or CRP, the 322.5 MHz signal will also be routed from A13J7 to A15J902 via W36 and from A15J900 to A2J100 via W37.

---

### Verifying the 22.5 MHz Output Power

1. Turn the instrument off.
2. Turn the instrument over so the bottom side of the analyzer is facing up.
3. Turn on the N9020A Signal Analyzer and wait for the instrument to complete the boot up process.
4. Press **System, Alignments, Auto Align, Off**.
5. Press **Input/Output, RF calibrator, 50 MHz**.
6. Verify the 50 MHz signal is at  $-25$  dBm by pressing **FREQ, 50 MHz, SPAN, 1 MHz, Peak Search** on the analyzer. The marker readout should be 50 MHz at  $-25$  dBm  $\pm$  3 dBm. If this reference signal is measuring incorrectly, see [Chapter 4, "RF Section Troubleshooting"](#) in this service guide.
7. To continue verifying press **SPAN, Zero Span**. Verify the input attenuator on the N9020A is set to 10 dB. Look near the top of the display near the center and verify that **Atten: 10 dB** is visible. If needed change the input attenuator by pressing **AMPTD, Attenuation, 10 dB** on the analyzer.
8. Refer to [Figure 6-3](#), carefully disconnect the W13 cable at A3J15.

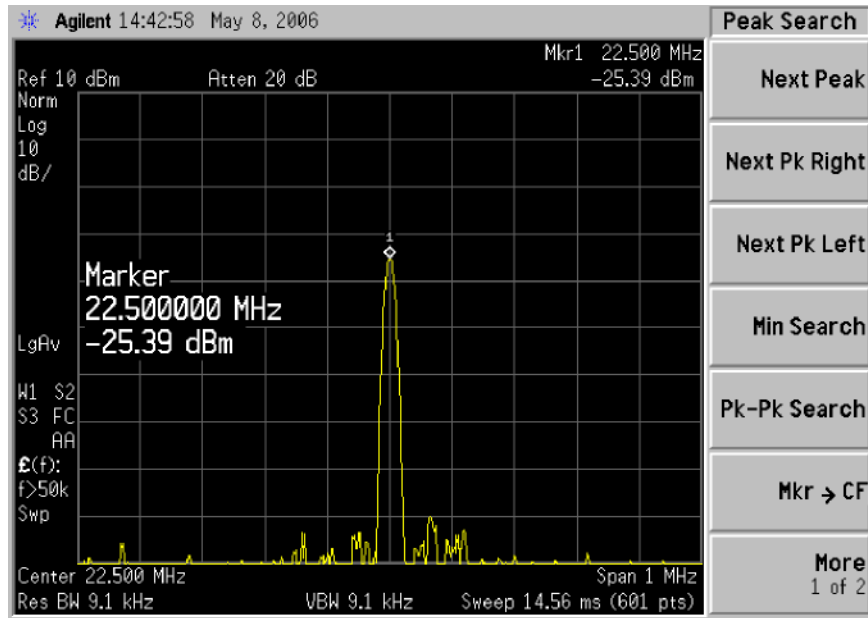
**Figure 6-3** A3 Digital I.F. Cables



w12\_bottom

9. Connect the W13 cable to the MMCX female to SMA female connector. Use an appropriate cable to go from the SMA connector to the RF input of a functioning spectrum analyzer to verify the 22.5 MHz I.F. and amplitude is correct.
10. Press **Freq, 22.5 MHz, Span, 1 MHz, Peak Search** on the functioning spectrum analyzer.
11. The analyzer marker should read 22.5 MHz at  $-25 \text{ dBm} \pm 4 \text{ dBm}$  as shown in **Figure 6-4**.

**Figure 6-4** A2 Analog I.F. Output



If the 22.5 MHz signal is not measuring the correct power level, do not assume the Analog I.F. is the most probable cause until the 3rd L.O. frequency and power level have been verified below.

If the 22.5 MHz signal is within tolerance, carefully reconnect the W13 cable.

**NOTE**

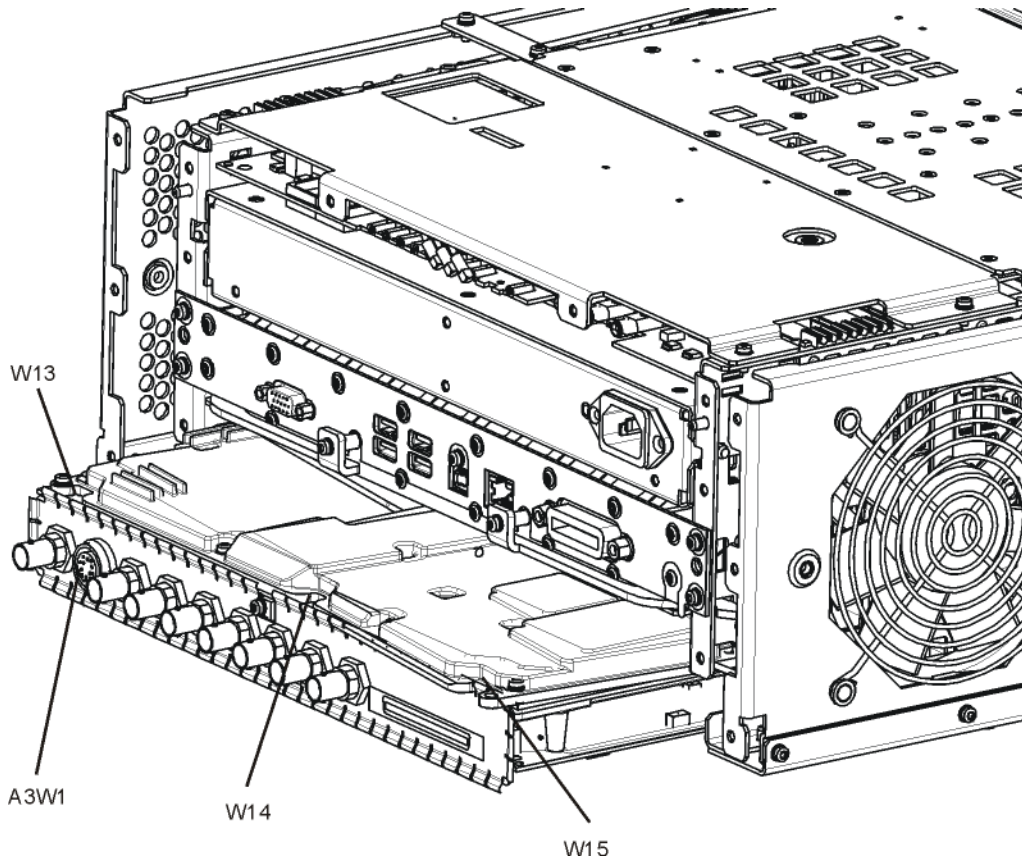
You should hear a distinct snap when reconnecting the W13 cable. If this cable is not installed properly, intermittent signal fluctuations may occur on the analyzer display.



### Verifying the 300 MHz L.O. Input Power from the A16 Reference Assembly

1. Refer to **Figure 6-5**, carefully disconnect the W14 at A2J300

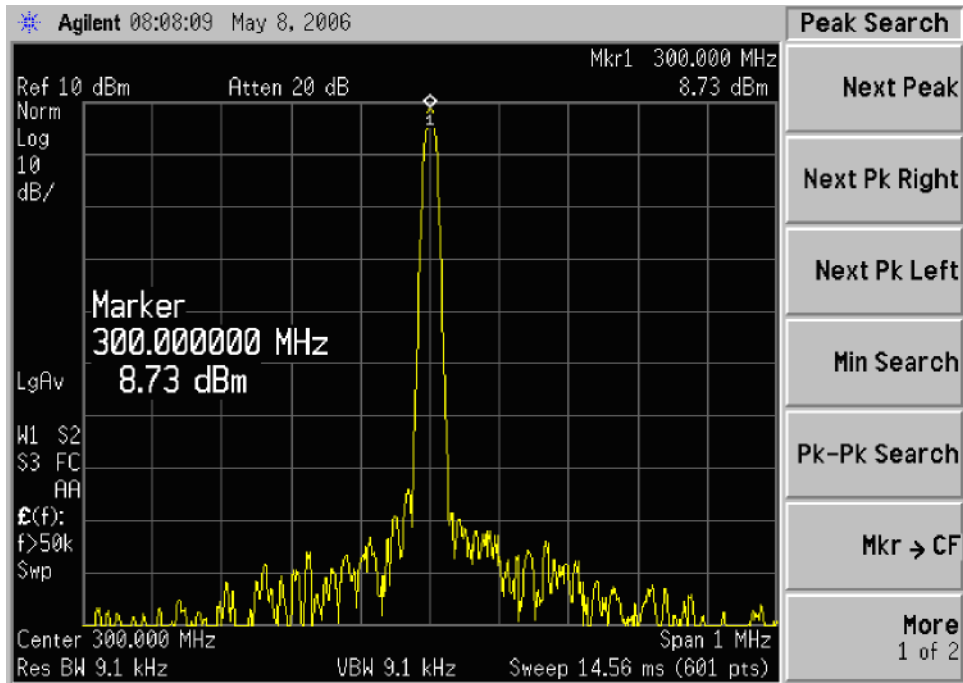
**Figure 6-5** A2 Analog I.F. Cables



2. Connect the W14 cable to the MMCX female to SMA female connector. Use an appropriate cable to go from the SMA connector to the RF input of a functioning spectrum analyzer.
3. Press **Freq, 300 MHz, Span, 1 MHz, Amplitude, 10 dBm, Peak Search** on the functioning spectrum analyzer.

- The analyzer marker should read 300 MHz at 10 dBm  $\pm$  3 dBm as shown in **Figure 6-6**.

**Figure 6-6** 300 MHz L.O.



If the 300 MHz signal is not measuring the correct power level, see the A16 Reference Assembly troubleshooting section in this service guide. If the 300 MHz L.O. is measuring the correct power level and frequency and the 22.5 MHz signal is low, the most probable cause is the A2 Analog I.F. assembly.

## A3 Digital I.F. Assembly Description

The A3 Digital I.F. has circuitry that is needed to analyze complex communication signals that can occupy up to 25 MHz of information bandwidth. It digitizes the final 22.5 MHz I.F. from the A2 Analog I.F. board, by processing the time domain continuous data into I/Q (in-phase and quadrature) signals before sending the data to the A4 CPU assembly for further processing and front panel display.

The Digital I.F. has the following main functions:

- Digitizes the final 22.5 MHz Intermediate Frequency
- 14 bit ADC with a 90 MHz sample rate
- DSP for standard spectrum analysis
- Capture memory for complex signals
- Noise Source Control
- Dither for final I.F.
- Provides the alignment sequence generator for wide band alignments
- Provides wide band Comb Calibration Signal
- Trigger interpolation and associated alignment

## A3 Digital I.F. Assembly Theory of Operation

**NOTE** Refer to **Chapter 11, “Block Diagrams.”**

---

### Data Acquisition

The 22.5 MHz IF comes from the A2 Analog IF assembly. The input level to the A3 Digital IF assembly is  $-25$  dBm. The IF input has a 25 MHz bandwidth centered at 22.5 MHz. The analog circuitry leading to the ADC converts the singled ended signal from the Analog IF to differential required by the ADC. In addition, it is part of a filter, part of which is on the AIF, which improves distortion. Finally, it couples in the dither signal. The ADC is a 14 bit device sampling continuously at 90 Ms/Second.

### Rear Panel Triggers

The board has two trigger inputs and two trigger outputs all used via a BNC connector. The trigger inputs are used when an external device has a trigger signal and the user wants to use that external trigger to trigger the signal analyzer. The trigger outputs are used to synchronize other pieces of test equipment to the analyzer. These outputs are configurable through the Input/Output menu via the front panel of the instrument.

The trigger inputs each allow trigger levels to be set from  $-5$  to  $+5$  volts using the control DAC. The circuits have relatively high input impedance. The trigger outputs have  $50\ \Omega$  source impedance with TTL drive levels into no load.

### Control DAC

The control DAC is used to set trigger levels and the gain of the reconstruction system. All three outputs can be adjusted from  $-2.5$  to  $+2.5$  volts.

### Sample Rate Generator

The 10 MHz reference signal comes from the A16 Reference Assembly. This signal is fairly high power at  $+10$  dBm. The signal goes through a 10 MHz to 30 MHz tripler. A 0 to 5V 10 MHz square wave is generated. Capacitors form a single-pole band pass filter to select the 3rd harmonic, 30 MHz.

The signal then passes through a 30 MHz to 90 MHz tripler. A 0 to 5V 30 MHz square wave is generated. Capacitors form a single-pole band pass filter to select the 3rd harmonic, 90 MHz.

### **Noise Source Voltage Regulator**

Various external noise sources can be connected to the rear panel of the analyzer. These noise sources require a very accurate 28 volt DC power supply.

The 28 volt BNC output connector is used with the 346 series noise sources.

The Smart Noise Source (SNS) interface includes power switching for the 28 volt and 15 volt power supply. In addition, it has buffers to interface to the SNS I2C bus for control and read back of ENR data automatically. The SNS connector is used with the SNS series noise sources.

### **DSP**

The signal from the ADC is sent to the Digital Signal Processor.

### **Digital Bus Common Mode Filtering**

The Digital Bus is a real time digital interface. It is sometimes referred to as Messenger or LVDS. The implementation on the Digital IF is unidirectional, meaning it can only source data, not receive it. Common mode filtering is required to translate the digital ground referenced signals to analog ground at the rear panel.

## A3 Digital I.F. Troubleshooting

### Verifying the 22.5 MHz Input Power

1. Perform an instrument shut down.
2. Remove the cover of the analyzer. Refer to [Chapter 14, "Assembly Replacement Procedures"](#), on page 435 in this service guide.
3. Turn the instrument over so that the bottom is facing up.
4. Turn on the analyzer and wait for the instrument to complete the boot up process.
5. Press **System, Alignments, Auto Align, Off**
6. Press **Input, RF Calibrator, 50 MHz**
7. Verify the 50 MHz signal is at  $-25$  dBm by pressing **FREQ, 50 MHz, SPAN, 1 MHz, Peak Search** on the analyzer. The marker readout should be 50 MHz at  $-25$  dBm  $\pm$  3 dBm. If this reference signal is measuring incorrectly, see [Chapter 4, "RF Section Troubleshooting"](#), on page 137 in this service guide.
8. To continue verifying press **SPAN, Zero Span**. Verify the input attenuator on the analyzer is set to 10 dB. (Look near the top of the display near the center and verify Atten: 10 dB)

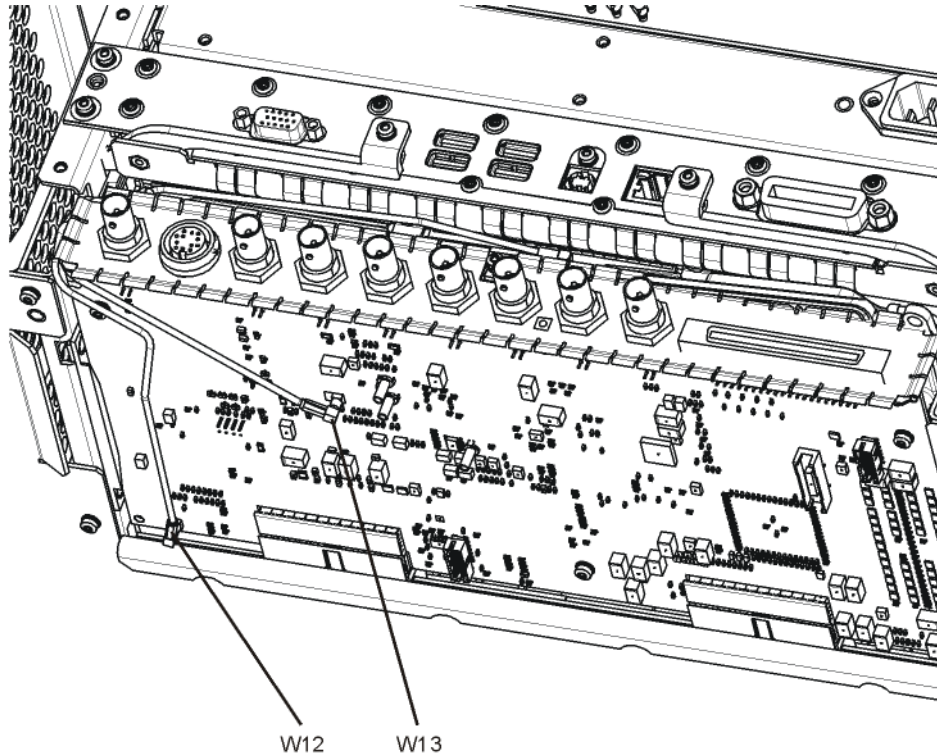
**NOTE**

If the analyzer is not in 10 dB of input attenuation press **AMPTD, Attenuation, 10 dB**.

---

9. Refer to **Figure 6-7**, carefully disconnect W13 at A3J15.

**Figure 6-7** A3 Digital I.F. Cables

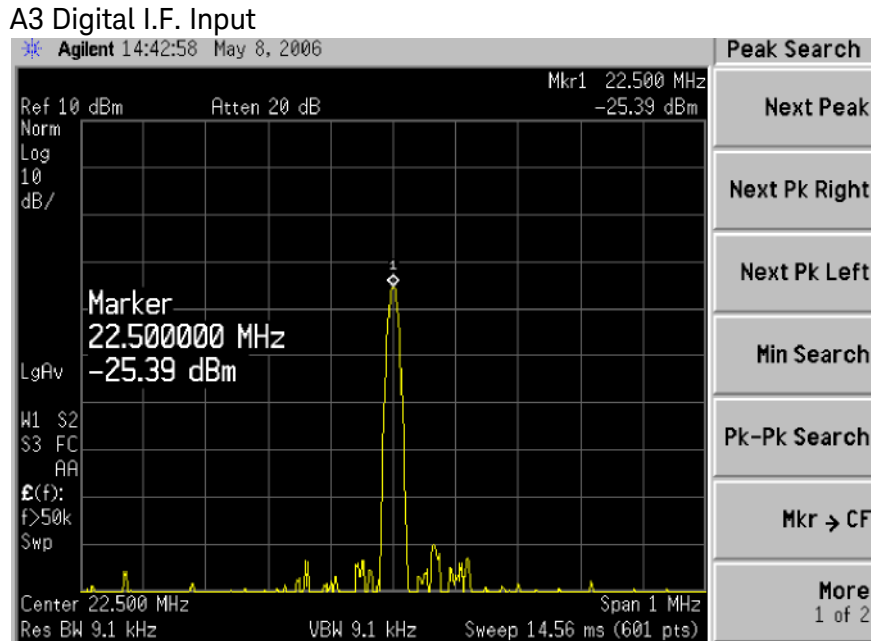


w12\_bottom

10. Connect the W13 cable to the MMCX female to SMA female connector. Use an appropriate cable to go from the SMA connector to the RF input of a functioning spectrum analyzer.
11. Press **Freq, 22.5 MHz Span, 1 MHz, Peak Search** on the functioning spectrum analyzer.

12. The analyzer should read 22.5 MHz at  $-25 \text{ dBm} \pm 4 \text{ dB}$  as shown in [Figure 6-8](#).

Figure 6-8



If the 22.5 MHz signal is not measuring the correct power level, see [“A2 Analog I.F. Troubleshooting”](#) on page 236 in this service guide.

### Verifying the 10 MHz Reference Input

1. Perform an instrument shut down.
2. Remove the cover of the analyzer. Refer to [Chapter 14, “Assembly Replacement Procedures”](#), on page 435 in this service guide.
3. Turn the instrument over so that the bottom is facing up.
4. Turn on the analyzer and wait for the instrument to complete the boot up process.
5. Press **System, Alignments, Auto Align, Off**.
6. Press **Input/Output, RF calibrator, 50 MHz**.
7. Verify the 50 MHz signal is at  $-25 \text{ dBm}$  by pressing **FREQ, 50 MHz, SPAN, 1 MHz, Peak Search** on the analyzer. The marker readout should be 50 MHz at  $-25 \text{ dBm} \pm 3 \text{ dBm}$ . If this reference signal is measuring incorrectly, see [Chapter 4, “RF Section Troubleshooting”](#), on page 137 in this service guide.
8. To continue verifying press **SPAN, Zero Span**. Verify the input attenuator on the analyzer is set to 10 dB. (Look near the top of the display near the center and verify Atten: 10 dB)

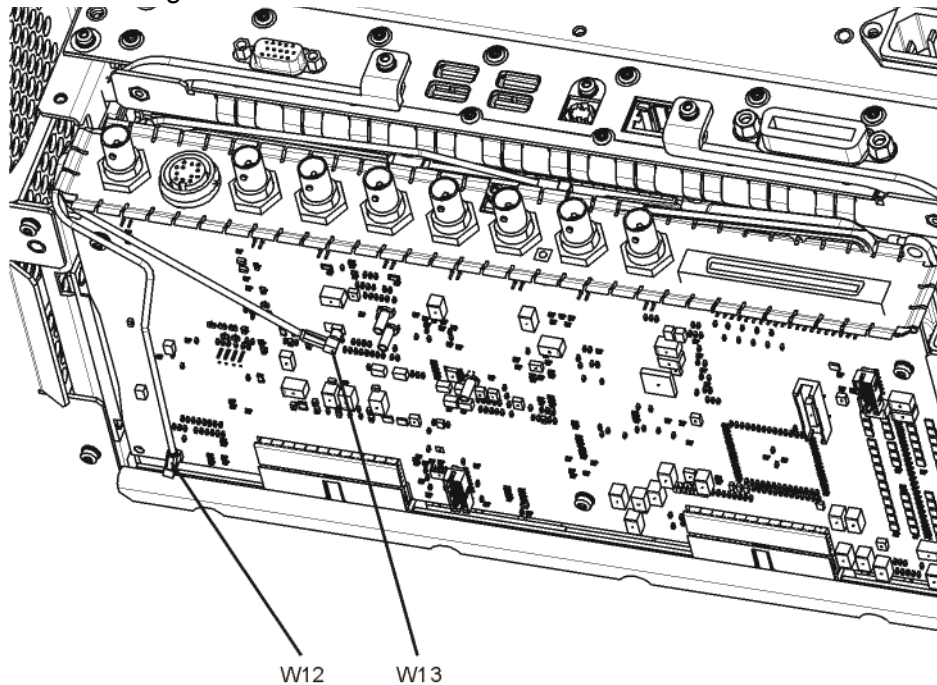


**NOTE** If the analyzer is not in 10 dB of input attenuation press **AMPTD**, **Attenuation**, **10 dB**.

---

9. Refer to **Figure 6-9**, carefully disconnect W12 at A3J14.

**Figure 6-9** A3 Digital I.F. Cables

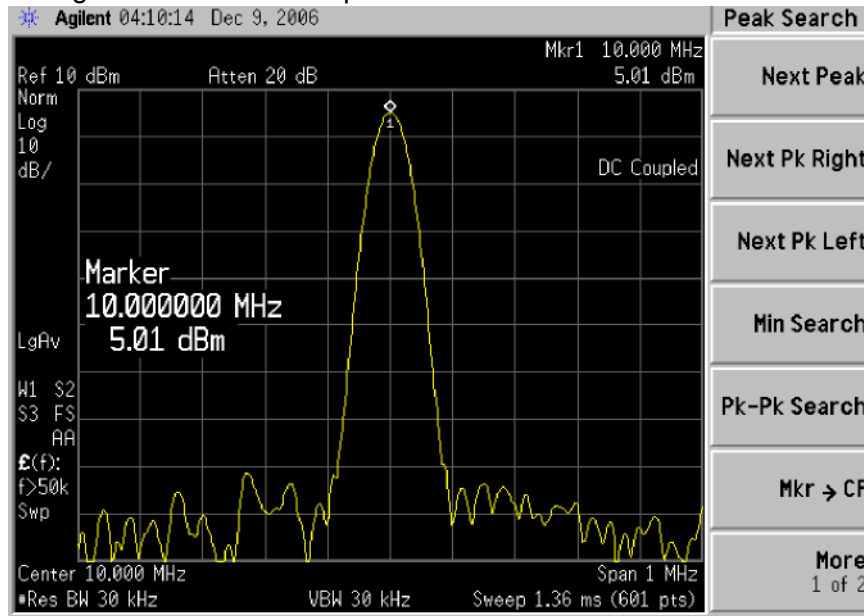


w12\_bottom

10. Connect the W12 cable to the MMCX female to SMA female connector. Use an appropriate cable to go from the SMA connector to the RF input of a functioning spectrum analyzer.
11. Press **Freq**, **10 MHz**, **Span**, **1 MHz**, **Peak Search** on the functioning spectrum analyzer.

12. The analyzer should read 10 MHz at +5 dBm  $\pm$  3 dBm as shown in **Figure 6-10**.

**Figure 6-10** A3 Digital I.F. Reference Input



If the 22.5 MHz and 10 MHz signals measure the correct frequency and amplitude and yet the display is not processing the signal properly, the most probable causes are the A3 Digital IF or the A4 CPU. It is difficult to separate these two assemblies given the architecture of the analyzer. Each assembly will have to be tried to see which one is causing the failure.

## 40 MHz BW IF Section

### A2 Analog IF Assembly Description

When the 10 MHz or 25 MHz IF Path is selected, or when any swept measurement is made, the analyzer's RF input signal is down converted to a 322.5 MHz intermediate frequency in the A13 RF Front End Assembly. This 322.5 MHz signal is routed through the IF MUX on the A15 Front End Control Assembly and then input to the A2 Analog I.F. Assembly.

The Analog I.F. down converts the 322.5 MHz signal to a final 22.5 MHz intermediate frequency. In order to obtain optimal dynamic range and minimize unwanted spurious signals, this signal is filtered, amplified and attenuated throughout this assembly. The final 22.5 MHz signal goes through a series of variable band pass filters each having a specific bandwidth. Three things determine the signal path and which filters are chosen:

- Instrument resolution bandwidth (RBW) setting
- Application used
- Mode applied

This assembly contains one of the two burst carrier trigger (BCT) circuits for performing mobile communication measurements. The BCT on the A2 assembly is relatively narrowband. The other BCT circuit is part of the IF MUX on the A15 Front End Control Assembly and has a much wider bandwidth.

The output of the A2 assembly is a filtered 22.5 MHz signal that goes to one of the two ADCs on the A3 Digital I.F. Assembly.

#### **Inputs to the A2**

- 322.5 MHz signal (from A15 Front End Control Assembly)
- LO Input (300 MHz signal from A16 Reference Assembly)
- 22.5 MHz Cal Comb Signal (from the A3 Digital IF Assembly)

#### **Outputs from the A2**

- 22.5 MHz signal (to A3 Digital IF Assembly)
- RF Trigger Detector (to A3 Digital IF Assembly)

## A2 Analog IF Assembly Theory of Operation

**NOTE** Refer to **Chapter 11, “Block Diagrams”**.

---

### **Input Switch and Filter**

A 322.5 MHz input signal is received from the A15 Front End Control Assembly. The signal then goes through a band pass filter centered at 322.5 MHz with a 25 MHz bandwidth. A comb cal signal can be automatically switched in at the input of the assembly to calibrate the prefilters.

### **Step Attenuator and Amplifier**

A 1 dB step attenuator follows to compensate for band gain differences. The signal then goes through a high-dynamic range amplifier.

### **Image Filters**

One of three different filter paths will be selected automatically, depending on the analyzer mode.

- The through path is selected in IQ Analyzer Mode and wide-band demod.
- The 12 MHz ceramic bandpass filter is used for normal Signal Analyzer swept and FFT operation.
- The 300 kHz Surface Acoustic Wave (SAW) is used for ACP modes.

### **Mixer**

There are two mixers that reside on this assembly. The first mixer is used to down convert the 322.5 MHz input to the final 22.5 MHz IF. The other mixer is described in the IF Comb Cal section.

### **3rd LO**

The 300 MHz 3rd LO signal comes from the A16 Reference Assembly and conditions it for use as an LO in the two mixers that reside on this assembly. The third LO power is ~ +10 dBm to optimize the conversion efficiency of the first mixer.

### **IF Comb Cal**

The 2nd mixer is used to mix the 300 MHz LO from the Reference Assembly with the 22.5 MHz cal comb signal from the A3 Digital IF to allow calibration of the prefilters and overall passband phase and amplitude. The signal is attenuated by 20 dB if necessary.

### Post Down Conversion Amplification and Prefiltering

The 22.5 MHz IF goes through a fixed gain amplifier. Then prefilters are switched in and out. The signal then goes through a variable gain amplifier.

The prefilters provide four single-pole filters to limit the bandwidth of the signal reaching the ADC on the A3 Digital IF assembly. There are five different signal paths for the 22.5 MHz IF when using Signal Analyzer swept mode:

1. LC wide
2. LC narrow
3. Crystal wide
4. Crystal narrow
5. Through path

The LC wide signal path is used when the analyzer Res BW setting is 180 kHz to 390 kHz.

The LC narrow signal path is used when the analyzer Res BW setting is 30 kHz to 160 kHz.

The Crystal wide signal path is used when the analyzer Res BW setting is 4.3 kHz to 27 kHz.

The Crystal narrow signal path is used when the analyzer Res BW setting is < 3.9 kHz.

The through path is used when the analyzer Res BW setting is 430 kHz and greater in analyzer swept mode.

#### NOTE

In IQ Analyzer mode or in Spectrum Analyzer mode with Sweep Type of FFT, the analyzer span setting determines the pre-filter settings.

---

### **Anti-Alias Filter and Final Amplifier**

The anti-alias filters attenuate unwanted out-of-band noise and distortion products. The first anti-alias filter is centered at 22.5 MHz and is 25 MHz wide.

The signal can bypass the second anti-alias filter when the analyzer utilizes either the IQ Analyzer swept, or wide-band demod.

The through path is selected when the image filter is in the 25 MHz mode (for IQ Analyzer swept and wide-band demod)

In all other cases the signal will pass through the second 12 MHz anti-alias filter.

The step gain block provides an additional switchable 10 dB gain to overcome the ADC noise floor and provide an additional 2 dB of analyzer sensitivity.

### **Burst Carrier Trigger**

The Burst Carrier Trigger detector provides a binary signal to be used as a trigger based on the presence of an RF input signal or not. The variable gain amplifiers drive a detector and its output drives a comparator which generates the trigger signal.

## A2 Analog IF Troubleshooting

There are three steps to verify the A2 Analog IF Assembly.

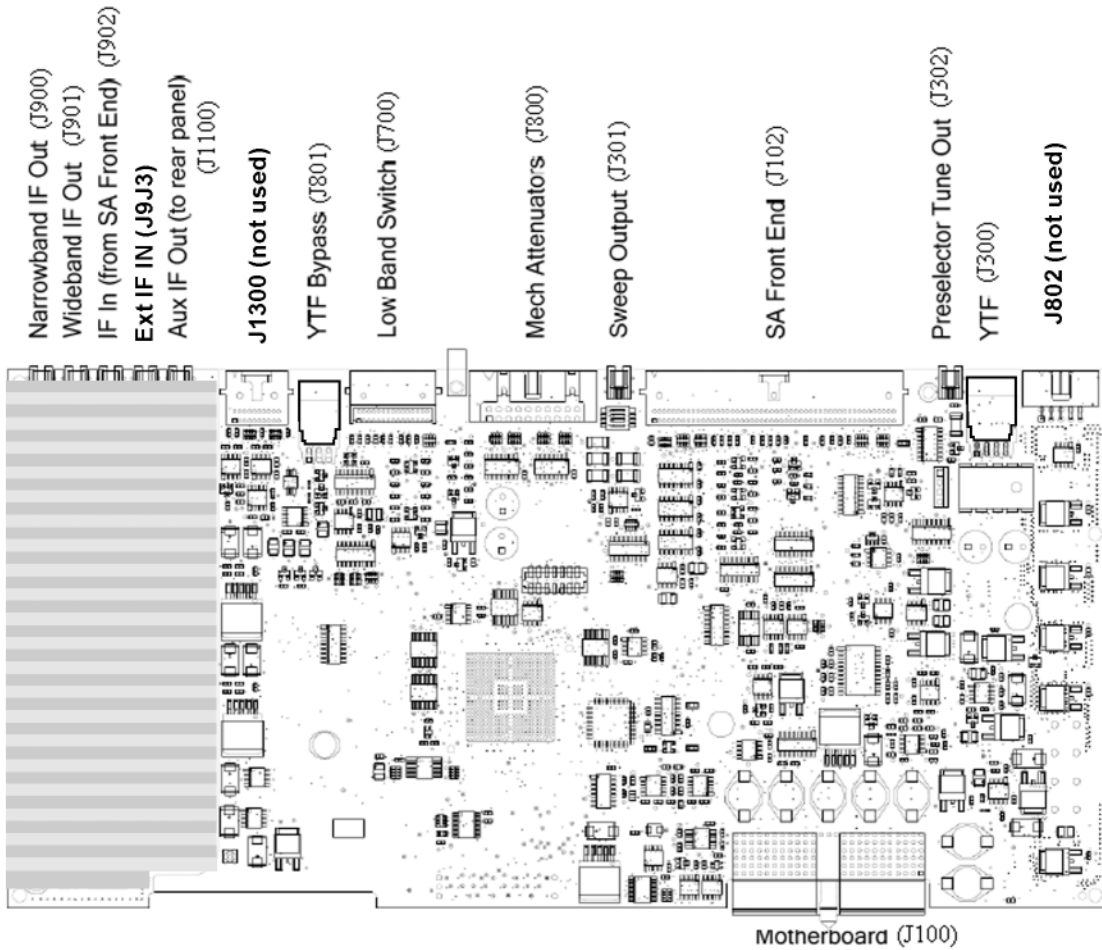
- Measure the input power and frequency accuracy of the 322.5 MHz signal (from the A13 RF Front End assembly)
- Measure the output power and frequency accuracy of the 22.5 MHz signal (to the A3 Digital IF Assembly)
- Measure the 300 MHz input LO signal (from the A16 Reference Assembly)

### Verifying the 322.5 MHz Input Power

1. Turn the instrument off.
2. Remove instrument cover. Refer to **Chapter 14, “Assembly Replacement Procedures”** in this service guide.
3. Turn on the analyzer and wait for the instrument to complete the boot up process.
4. Press **System, Alignments, Auto Align, Off**.
5. Press **Input/Output, RF calibrator, 50 MHz**.
6. Verify the 50 MHz signal is at  $-25$  dBm on the analyzer display by pressing **FREQ, 50 MHz, SPAN, 1 MHz, Peak Search** on the analyzer. The marker readout should be 50 MHz at  $-25$  dBm  $\pm$  3 dB. If this reference signal is measuring incorrectly, see **Chapter 4, “RF Section Troubleshooting”** in this service guide.
7. To continue verifying press **SPAN, Zero Span**. Verify the input attenuator on the analyzer is set to 10 dB. Look near the top of the display near the center and verify that **Atten: 10 dB** is visible. If needed change the input attenuator by pressing **AMPTD, Attenuation, 10 dB** on the analyzer.

- Carefully disconnect W37 cable at A15J900 as shown in [Figure 6-11](#).

**Figure 6-11** A15 RF Front End Control Assembly

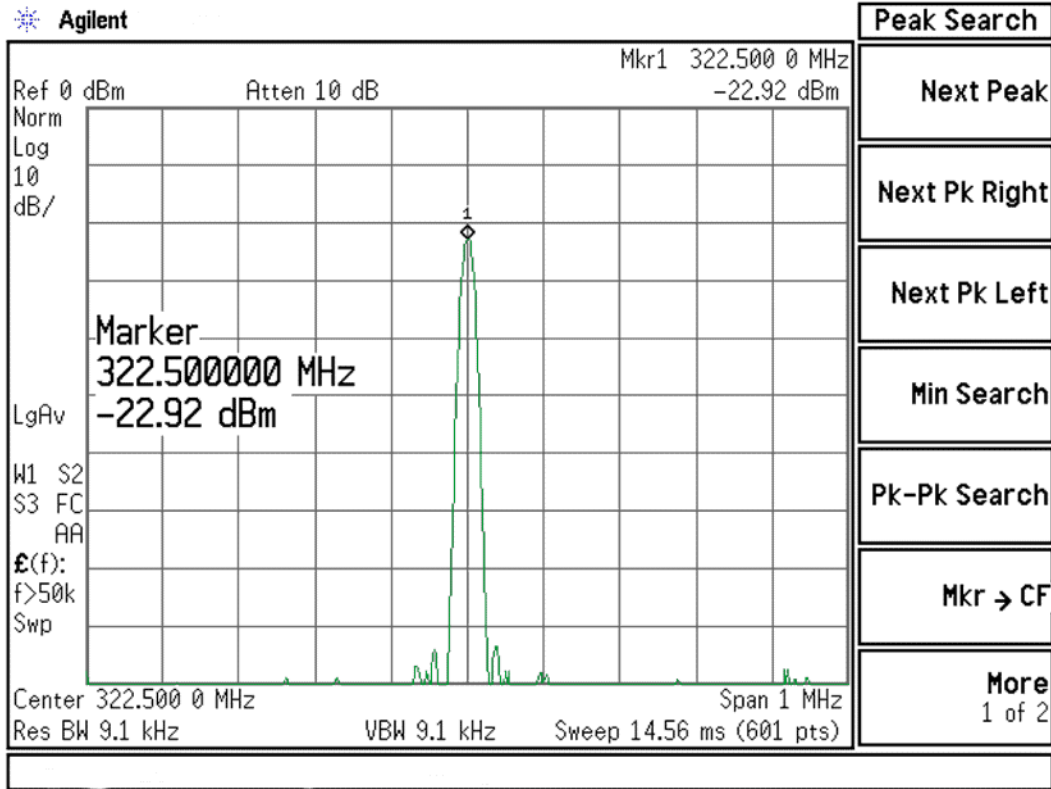


- Connect A15J900 to a functioning spectrum analyzer using the appropriate MMCX connectors and cables.
- Press **Freq, 322.5 MHz, Span, 1 MHz, Peak Search** on the functioning spectrum analyzer.



11. The analyzer should read 322.5 MHz at  $-23 \text{ dBm} \pm 3 \text{ dB}$  as shown in [Figure 6-12](#).

**Figure 6-12** A15 322.5 MHz Output



**NOTE** If the 322.5 MHz signal is not measuring the correct power level, refer to [Chapter 4, "RF Section Troubleshooting"](#) in this service guide.

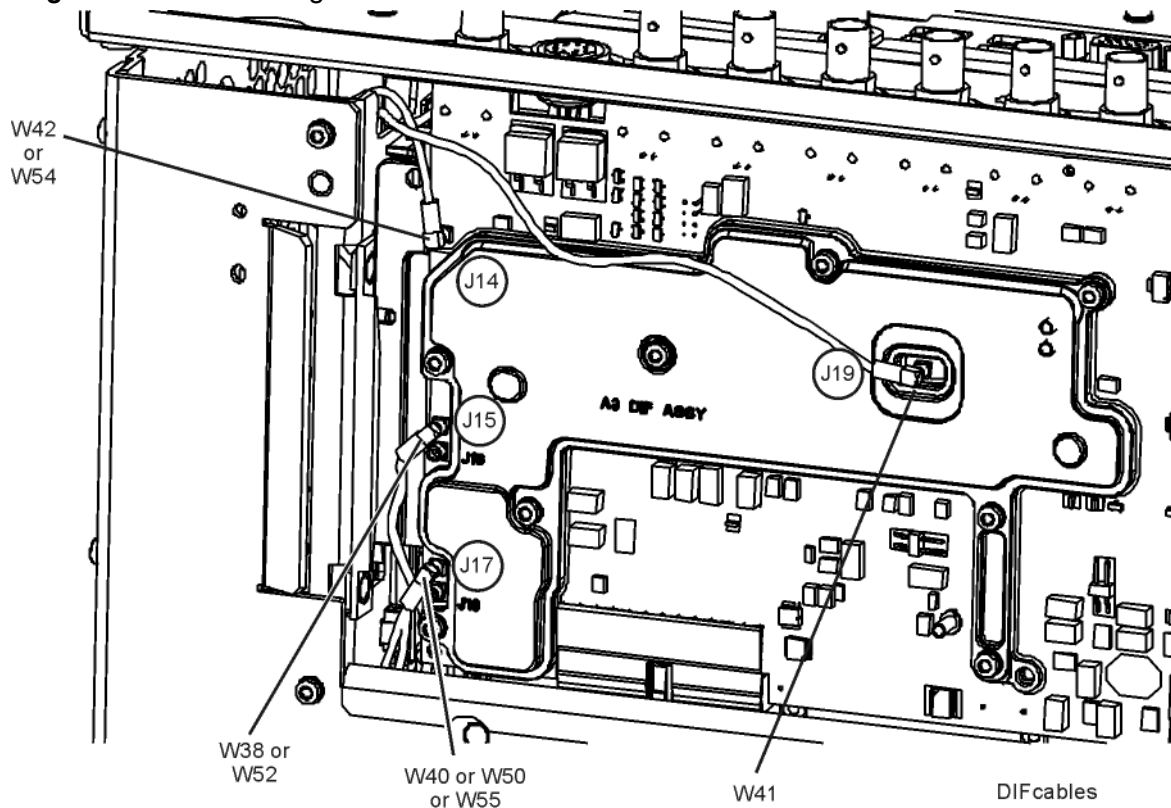
Reconnect W37 to A15J900.

**IMPORTANT** Measuring at this location is for convenience. The 322.5 MHz signal is an output at A15J900. Since the W37 cable connects from this output to the input of the Analog I.F. assembly at A2J100, the small coaxial cable has not been tested at the A2J100 end.

### Verifying the 22.5 MHz Output Power

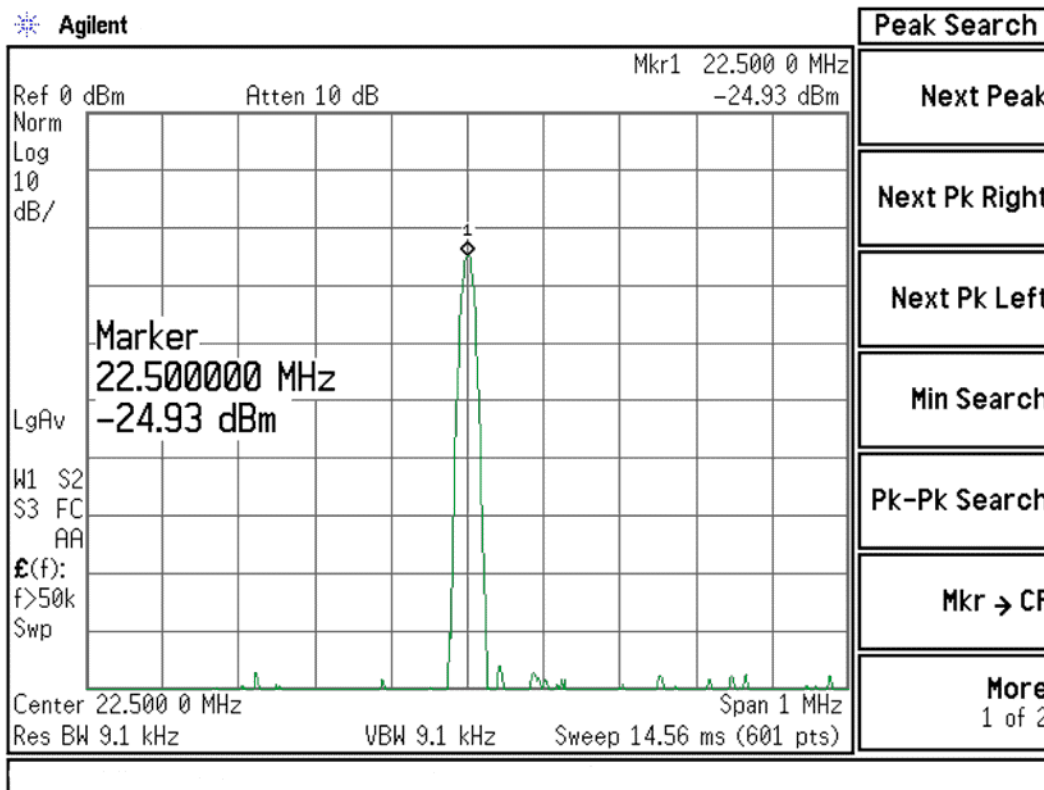
1. Perform an instrument shutdown.
2. Turn the instrument over so the bottom side of the analyzer is facing up.
3. Turn on the analyzer and wait for the instrument to complete the boot up process.
4. Press **System, Alignments, Auto Align, Off**.
5. Press **Input/Output, RF calibrator, 50 MHz**.
6. Verify the 50 MHz signal is at  $-25$  dBm by pressing **FREQ, 50 MHz, SPAN, 1 MHz, Peak Search** on the analyzer. The marker readout should be 50 MHz at  $-25$  dBm  $\pm$  3 dB. If this reference signal is measuring incorrectly, see [Chapter 4, "RF Section Troubleshooting"](#) in this service guide.
7. To continue verifying press **SPAN, Zero Span**. Verify the input attenuator on the analyzer is set to 10 dB. Look near the top of the display near the center and verify that **Atten: 10 dB** is visible. If needed change the input attenuator by pressing **AMPTD, Attenuation, 10 dB** on the analyzer.
8. Refer to [Figure 6-13](#), carefully disconnect the W41 cable at A3J19.

**Figure 6-13** A3 Digital IF Cables



9. Connect the W41 cable to the MMCX female to SMA female connector. Use an appropriate cable to go from the SMA connector to the RF input of a functioning spectrum analyzer to verify the 22.5 MHz I.F. and amplitude is correct.
10. Press **Freq, 22.5 MHz, Span, 1 MHz, Peak Search** on the functioning spectrum analyzer.
11. The analyzer marker should read 22.5 MHz at  $-25 \text{ dBm} \pm 4 \text{ dB}$  as shown in **Figure 6-14**.

**Figure 6-14** A2 Analog IF Output



12. If the 22.5 MHz signal is not measuring the correct power level, do not assume the Analog IF is the most probable cause until the 3rd LO frequency and power level have been verified below.
13. If the 22.5 MHz signal is within tolerance, carefully reconnect the W41 cable to A3J19.

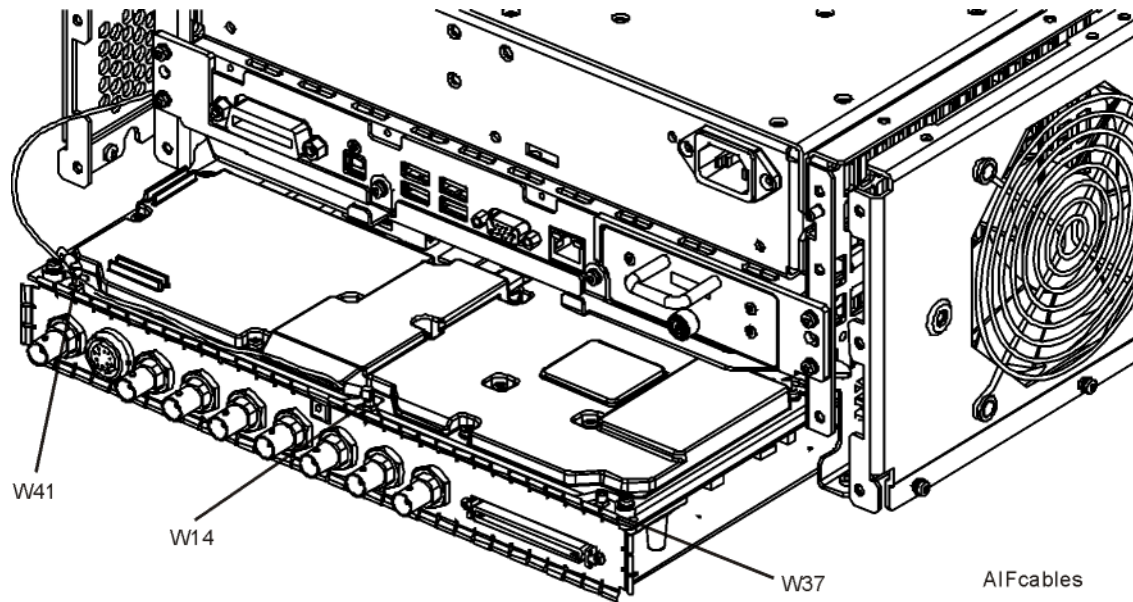
**NOTE**

You should hear a distinct snap when reconnecting the W41 cable. If this cable is not installed properly, intermittent signal fluctuations may occur on the analyzer display.

### Verifying the 300 MHz LO Input Power from the A16 Reference Assembly

1. Refer to **Figure 6-15**, carefully disconnect the W14 at A2J300.

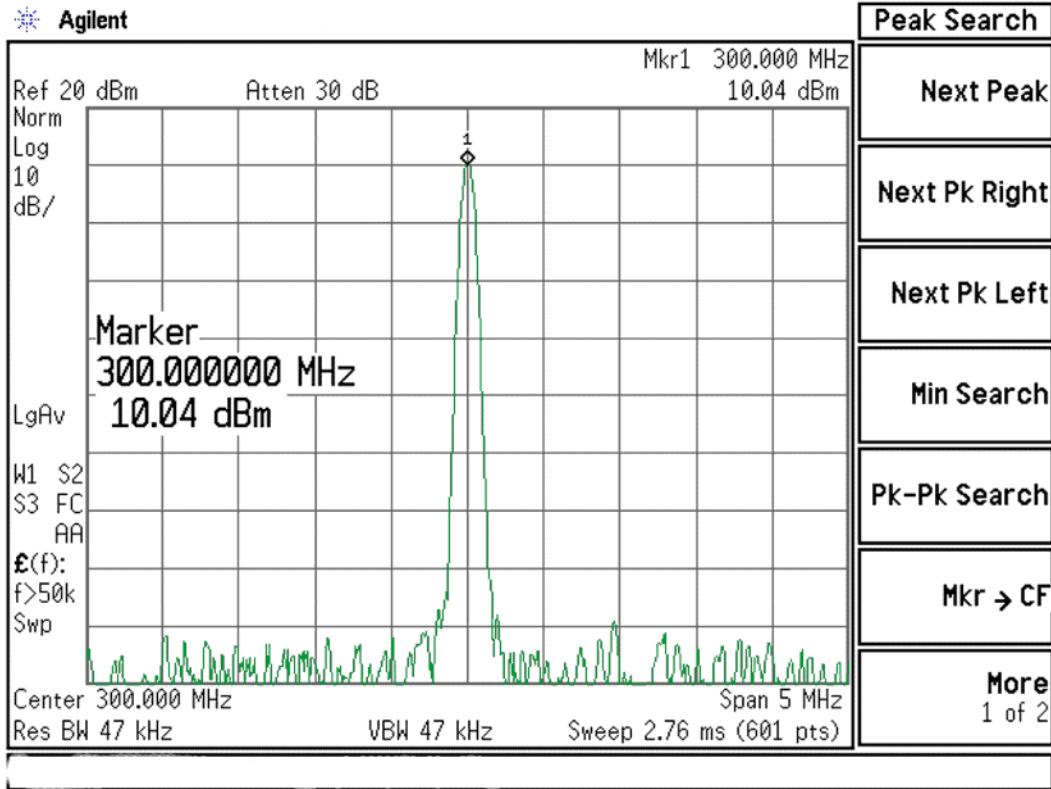
**Figure 6-15** A2 Analog IF Cables



2. Connect the W14 cable to the MMCX female to SMA female adapter. Use an appropriate cable to go from the SMA adapter to the RF input of a functioning spectrum analyzer.
3. Press **Freq, 300 MHz, Span, 1 MHz, Amplitude, 10 dBm, Peak Search** on the functioning spectrum analyzer.

- The analyzer marker should read 300 MHz at 10 dBm  $\pm$  3 dB as shown in **Figure 6-16**.

**Figure 6-16** 300 MHz LO



- If the 300 MHz signal is not measuring the correct power level, see the A16 Reference Assembly troubleshooting section in this service guide.
- If the 300 MHz LO is measuring the correct power level and frequency and the 22.5 MHz signal is low, the most probable cause is the A2 Analog IF assembly.

## A3 Digital IF Assembly Description

The A3 Digital I.F. has circuitry that is needed to analyze complex communication signals that can occupy up to 40 MHz of information bandwidth. This assembly has two inputs:

- 1. The final 22.5 MHz I.F. from the A2 Analog I.F. for IF bandwidth paths up to 25 MHz wide. This input is used for swept and FFT spectrum analysis.**
- 2. The 250 MHz IF from the A15 Front End Control Assembly for IF bandwidth of 40 MHz. If Option B85, B1A, or B1X is also installed, the 250 MHz IF will be routed to A3 via W53, A25, and W52.**

Each input has a separate ADC that processes the time domain continuous data into I/Q (in-phase and quadrature) signals before sending the data to the A4 CPU assembly for further processing and front panel display.

The Digital I.F. has the following main functions:

- Digitizes the 22.5 MHz and the 250 MHz IF signals
  - 16 bit ADC with a 100 MHz sample rate to digitize the 22.5 MHz IF
  - 12 bit ADC with a 200 MHz sample rate to digitize the 250 MHz IF
- DSP for standard spectrum analysis
- Capture memory for complex signals
- Noise Source Control
- Dither for final I.F
- Provides the alignment sequence generator for wide band alignments
- Provides wide band Comb Calibration Signal
- Trigger interpolation and associated alignment

## A3 Digital IF Assembly Theory of Operation

**NOTE** Refer to **Chapter 11, “Block Diagrams”**.

---

### Data Acquisition

The 22.5 MHz IF comes from the A2 Analog IF assembly. The input level to the A3 Digital IF assembly is  $-25$  dBm when observing the 50 MHz calibrator signal. The IF input has a 25 MHz bandwidth centered at 22.5 MHz. The analog circuitry leading to the ADC converts the singled ended signal from the Analog IF to differential required by the ADC. In addition, it is part of a filter, part of which is on the AIF, which improves distortion. Finally, it couples in the dither signal. The ADC is a 16 bit device sampling continuously at 100 Ms/second.

The 250 MHz IF comes from the A15 Front End Control assembly. The input level is approximately  $-25$  dBm when observing the 50 MHz calibrator signal. The IF input has a 40 MHz bandwidth centered at 250 MHz. The analog circuitry leading to the ADC converts the single-ended signal from the Front End Control to differential required by the ADC. Finally, it couples in the dither signal. The ADC is a 12-bit device sampling continuously at 200 Ms/second.

### Rear Panel Triggers

The board has two trigger inputs and two trigger outputs all used via BNC connectors on the rear panel. The trigger inputs are used when an external device has a trigger signal and the user wants to use that external trigger to trigger the signal analyzer. The trigger outputs are used to synchronize other pieces of test equipment to the analyzer. These outputs are configurable through the Input/Output menu via the front panel of the instrument.

The trigger inputs each allow trigger levels to be set from  $-5$  to  $+5$  volts using the control DAC. The circuits have relatively high input impedance. The trigger outputs have  $50 \Omega$  source impedance with TTL drive levels into no load.

### DSP

The outputs of the ADCs go to the T2 digital FPGA. T2 links the ADC with memory and the Feldspar DSP. T2 does all the swept SA DSP and orchestrates measurements. It also provides outputs to the reconstruction system. Feldspar is a DPSP ASIC which performs all the DSP for wide-band applications.

### Reconstruction

Analog data from the digital FPGA, T2, is fed into a DAC that recreates an analog signal. It can be either video or the demodulated audio. The signal can be routed to the analyzer's audio system (to listen to the demodulated signals) or to the ANALOG OUT connector on the rear panel.

### **Clock Distribution**

The 100 MHz reference from the A16 Reference Assembly feeds a power divider. One output of the divider is buffered, doubled, and filtered to generate the 200 MHz clock needed for ADC2, the ADC for the 40 MHz BW path,. The remaining output of the power divider is attenuated and buffered before being fed to the clock distribution IC. This IC generates all the other clocks needed by the A3 Digital I.F. Assembly as well as the 10 MHz OUT connector on the rear panel.

### **Noise Source Voltage Regulator**

Various external noise sources can be connected to the rear panel of the analyzer. These noise sources require a very accurate 28 volt DC power supply.

The 28 volt BNC output connector is used with the 346 series noise sources.

The Smart Noise Source (SNS) interface includes power switching for the 28 volt and 15 volt power supply. In addition, it has buffers to interface to the SNS I2C bus for control and read back of ENR data automatically. The SNS connector is used with the SNS series noise sources.

### **Digital Bus Common Mode Filtering**

The Digital Bus is a real time digital interface. It is sometimes referred to as Messenger or LVDS. The implementation on the Digital IF is unidirectional, meaning it can only source data, not receive it. Common mode filtering is required to translate the digital ground referenced signals to analog ground at the rear panel.



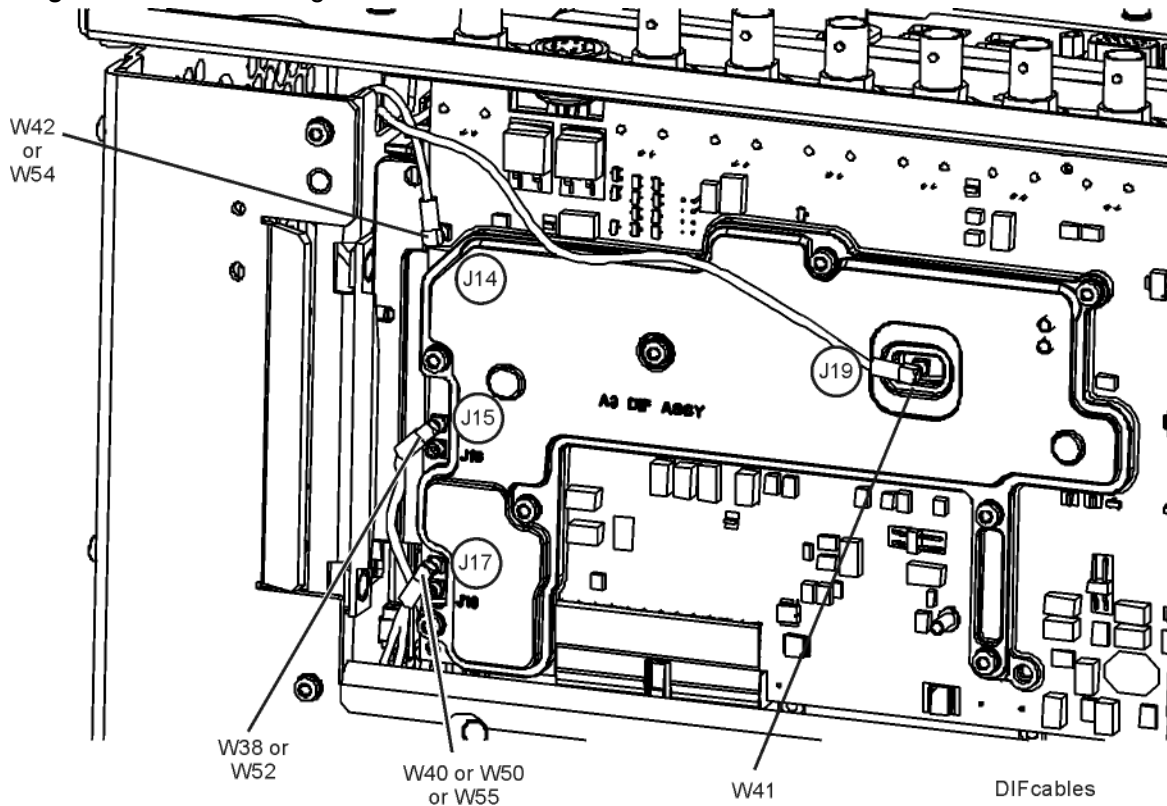
## A3 Digital IF Troubleshooting

### Verifying the 22.5 MHz Input Power

1. Perform an instrument shutdown.
2. Remove the cover of the analyzer. Refer to [Chapter 14, “Assembly Replacement Procedures”](#) in this service guide.
3. Turn the instrument over so that the bottom side of the analyzer is facing up.
4. Turn on the analyzer and wait for the instrument to complete the boot up process.
5. Press **System, Alignments, Auto Align, Off**
6. Press **Input/Output, RF Calibrator, 50 MHz**
7. Verify the 50 MHz signal is at  $-25$  dBm by pressing **FREQ, 50 MHz, SPAN, 1 MHz, Peak Search** on the analyzer. The marker readout should be 50 MHz at  $-25$  dBm  $\pm$  3 dB. If this reference signal is measuring incorrectly, see [Chapter 4, “RF Section Troubleshooting”](#) in this service guide.
8. To continue verifying press **SPAN, Zero Span**. Verify the input attenuator on the analyzer is set to 10 dB. Look near the top of the display near the center and verify **Atten: 10 dB** is visible. If needed change the input attenuator by pressing **AMPTD, Attenuation, 10 dB** on the analyzer.

9. Refer to **Figure 6-17**, carefully disconnect W41 cable at A3J19.

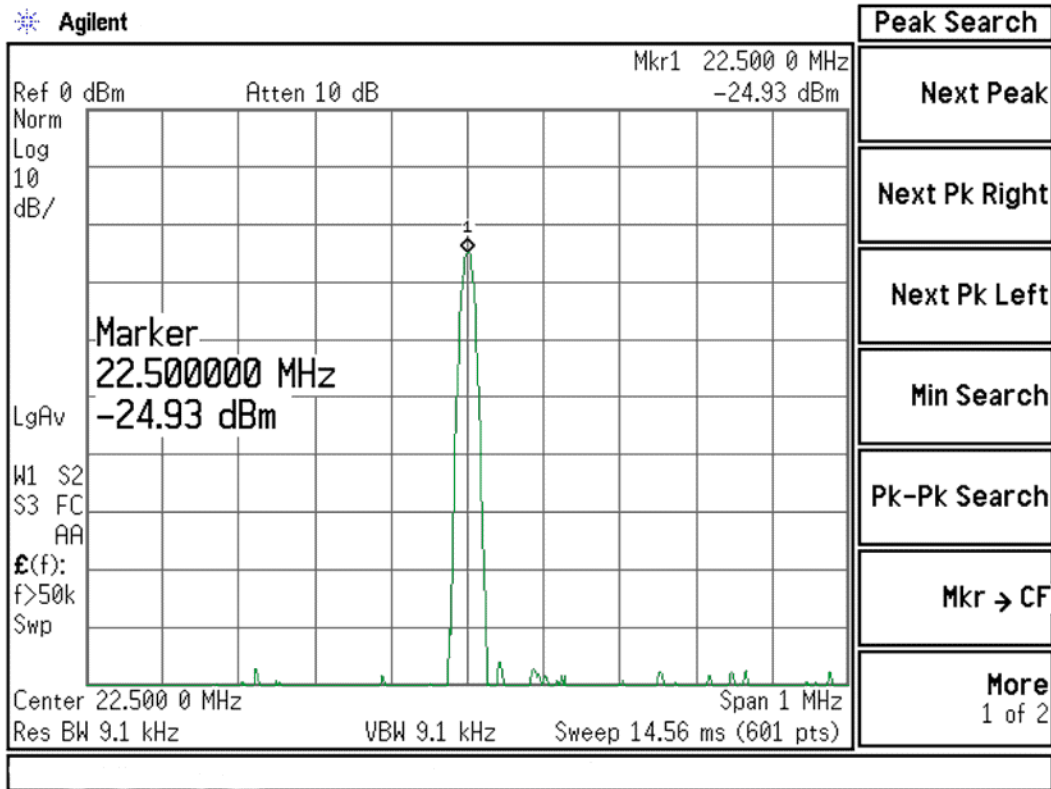
**Figure 6-17** A3 Digital IF Cables



10. Connect the W41 cable to the MMCX female to SMA female connector. Use an appropriate cable to go from the SMA connector to the RF input of a functioning spectrum analyzer to verify the 22.5 MHz I.F. signal frequency and amplitude is correct.
11. Press **Freq, 22.5 MHz Span, 1 MHz, Peak Search** on the functioning spectrum analyzer.

12. The analyzer should read 22.5 MHz at  $-25 \text{ dBm} \pm 4 \text{ dB}$  as shown in [Figure 6-18](#).

**Figure 6-18** 22.5 MHz IF Input



13. If the 22.5 MHz signal is not measuring the correct power level, see [“A2 Analog I.F. Troubleshooting”](#) on page 236 in this service guide.

14. If the 22.5 MHz signal is within tolerance, carefully reconnect the W41 cable to A3J19.

### Verifying the 250 MHz IF Input Power (Option B40 only)

**NOTE**

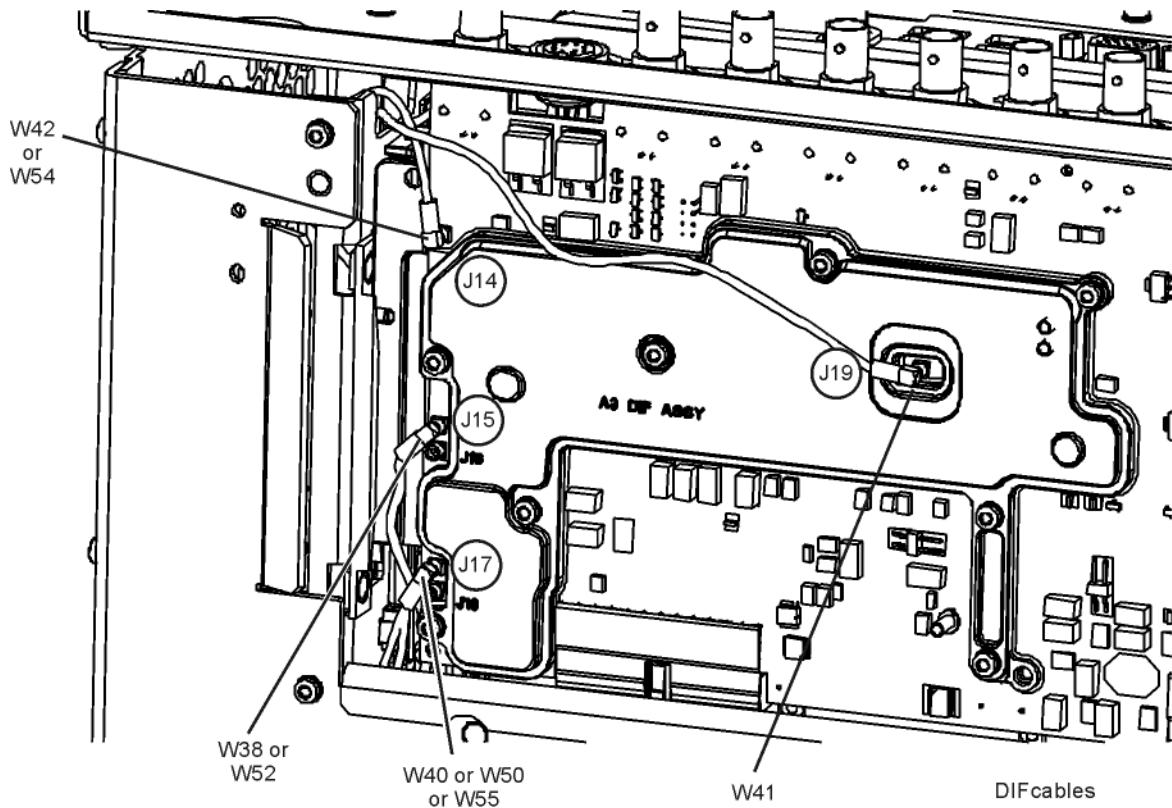
Perform this procedure only if the analyzer is equipped with Option B40, Analysis Bandwidth, 40 MHz

---

1. Perform an instrument shutdown.
2. Remove the cover of the analyzer. Refer to [Chapter 14, "Assembly Replacement Procedures"](#) in this service guide.
3. Turn the instrument over so that the bottom side of the analyzer is facing up.
4. Turn on the analyzer and wait for the instrument to complete the boot up process.
5. Press **Mode, IQ Analyzer (Basic), Mode Setup, IF Path, 40 MHz**.
6. Press **System, Alignments, Auto Align, Off**.
7. Press **Input/Output, RF calibrator, 50 MHz**.
8. Verify the 50 MHz signal is at  $-25$  dBm by pressing **FREQ, 50 MHz, SPAN, 1 MHz, Peak Search** on the analyzer. The marker readout should be 50 MHz at  $-25$  dBm  $\pm$  3 dB. If this reference signal is measuring incorrectly, see [Chapter 4, "RF Section Troubleshooting"](#) in this service guide.
9. To continue verifying press **Meas, IQ Waveform**. Verify the input attenuator on the analyzer is set to 10 dB. Look near the top of the display near the center and verify **Atten: 10 dB** is visible. If needed change the input attenuator by pressing **AMPTD, Attenuation, 10 dB** on the analyzer

10. Refer to **Figure 6-19**, carefully disconnect W38 or W52.

**Figure 6-19** A3 Digital IF Cables

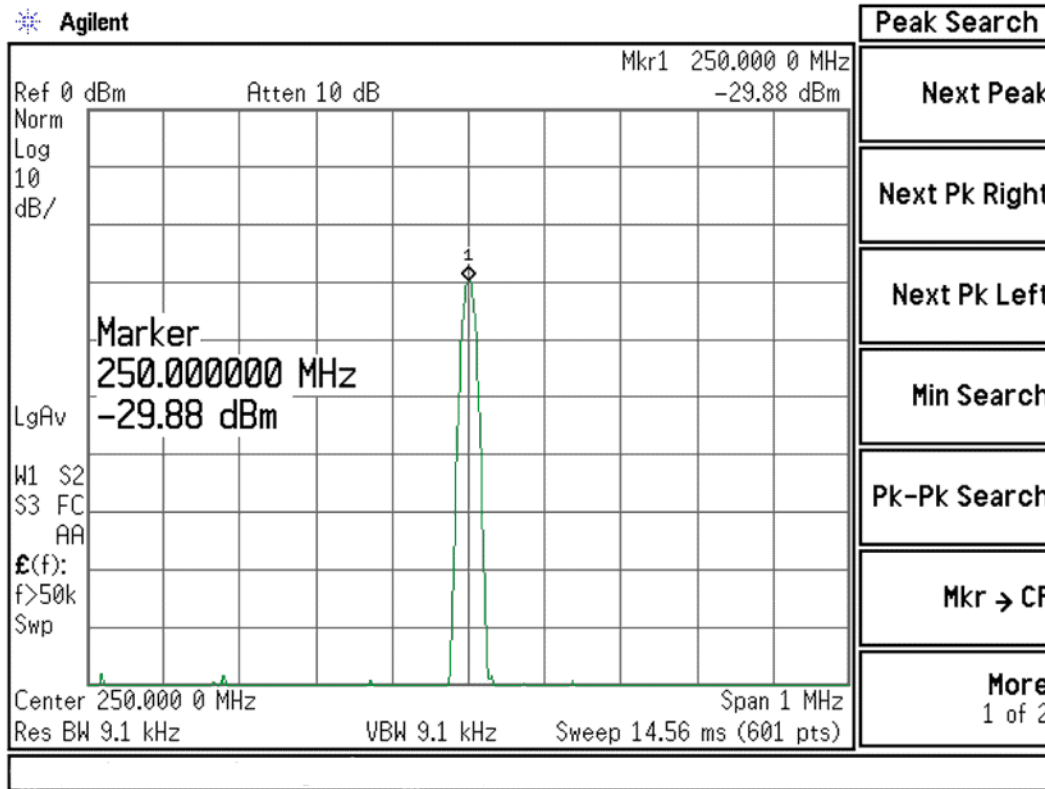


11. Connect the W38 or W52 cable to the MMCX female to SMA female connector. Use an appropriate cable to go from the SMA connector to the RF input of a functioning spectrum analyzer to verify the 250 MHz I.F. signal frequency and amplitude is correct.

12. Press **Freq, 250 MHz, Span, 1 MHz, Peak Search** on the functioning spectrum analyzer.

13. The analyzer marker should read 250 MHz at  $-30 \text{ dBm} \pm 4 \text{ dB}$  as shown in Figure 6-20.

Figure 6-20 250 MHz IF Input



14. If the 250 MHz signal is not measuring the correct power level and neither of Options B85, B1A, or B1X are present, see Chapter 5, “Front End Control Troubleshooting” in this service guide. If the 250 MHz signal is not measuring the correct power level and either Option B85, B1A, or B1X is installed, see “A25 Wideband Troubleshooting” later in this chapter.

15. If the 250 MHz signal is within tolerance, carefully reconnect the W38 or W52 cable to A3J15.

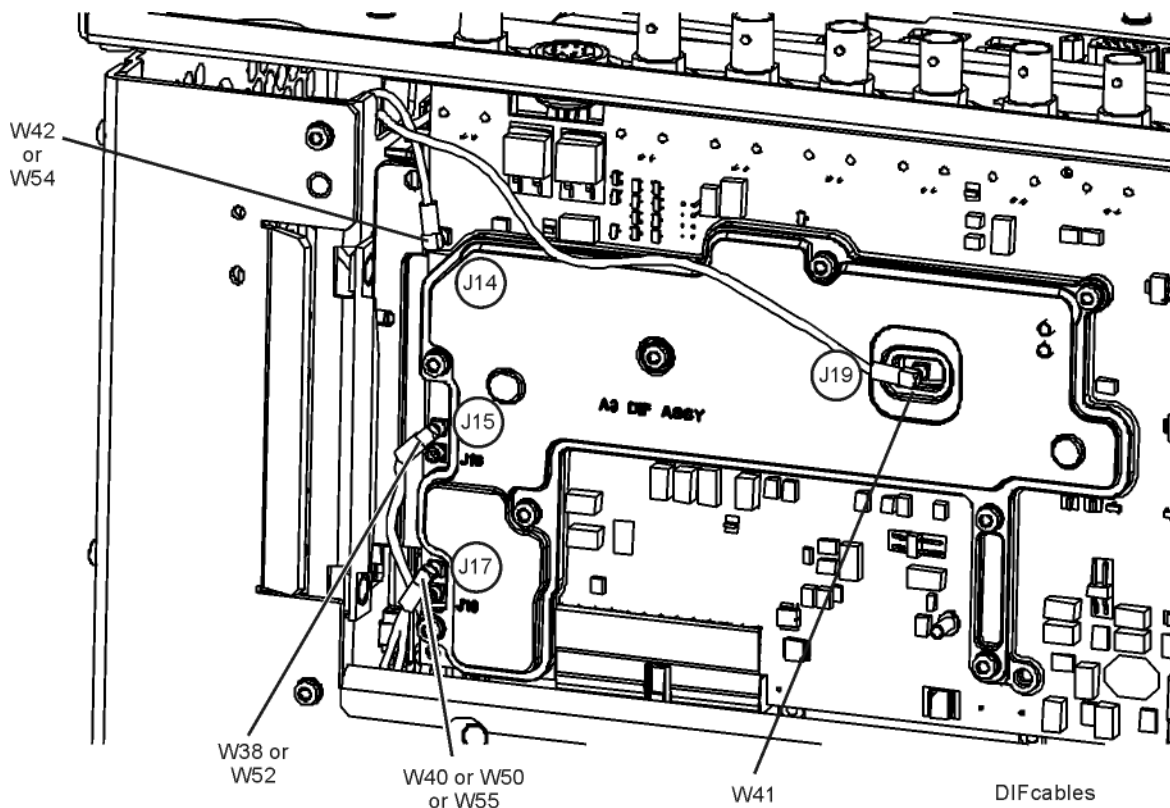
**NOTE**

You should hear a distinct snap when reconnecting the cable. If this cable is not installed properly, intermittent signal fluctuations may occur on the analyzer display.

### Verifying the 100 MHz Reference Input

1. Perform an instrument shutdown.
2. Remove the cover of the analyzer. Refer to [Chapter 14, “Assembly Replacement Procedures”](#) in this service guide.
3. Turn the instrument over so that the bottom side of the analyzer is facing up.
4. Turn on the analyzer and wait for the instrument to complete the boot up process.
5. Press **System, Alignments, Auto Align, Off**.
6. Press **Input/Output, RF calibrator, 50 MHz**.
7. Refer to [Figure 6-21](#), carefully disconnect W42 or W54 cable at A3J14.

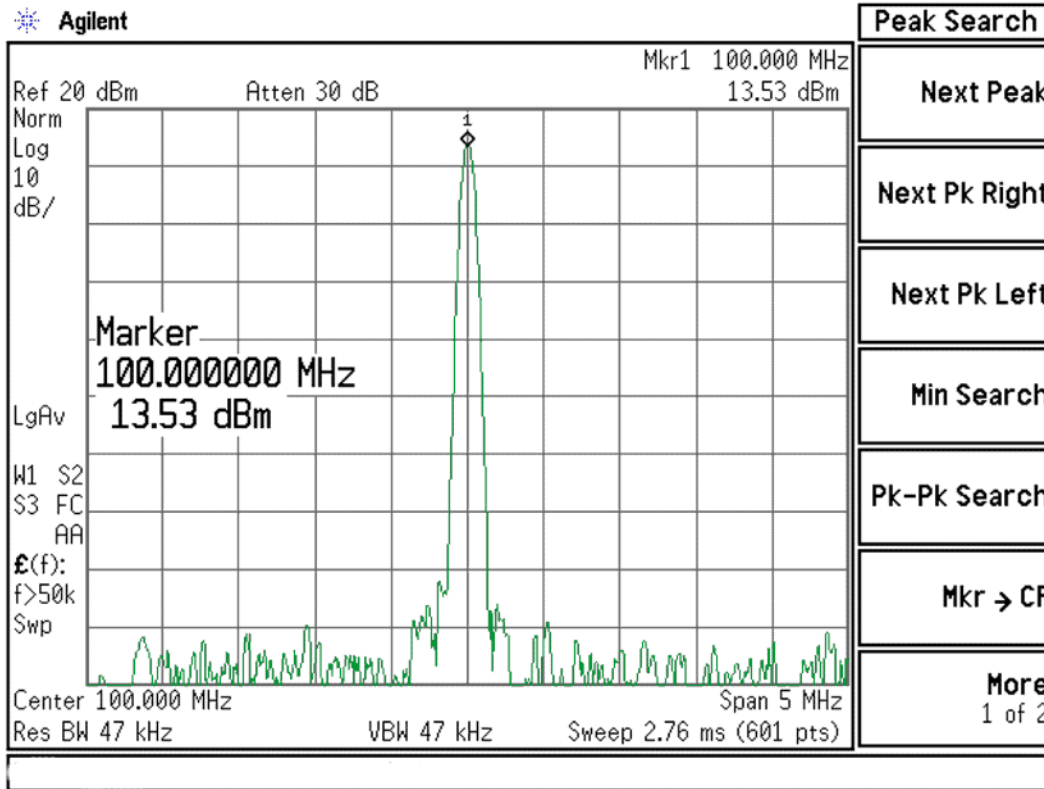
**Figure 6-21** A3 Digital IF Cables



8. Connect the W42 or W54 cable to the MMCX female to SMA female connector. Use an appropriate cable to go from the SMA connector to the RF input of a functioning spectrum analyzer to verify the 100 MHz reference frequency and amplitude is correct.
9. Press **AMPTD, Ref Level, 20 dBm, Freq, 100 MHz, Span, 1 MHz, Peak Search** on the functioning spectrum analyzer.

10. The analyzer marker should read 100 MHz at +10 dBm  $\pm$  4 dB as shown in Figure 6-22.

Figure 6-22 100 MHz Reference Input



11. If the 100 MHz signal is measuring incorrectly, see Chapter 7, "L.O. Synthesizer/Reference Troubleshooting" in this service guide.

12. If the 22.5 MHz IF, 250 MHz IF (if appropriate) and 100 MHz reference signals measure the correct frequency and amplitude and yet the display is not processing the signal properly, the most probable causes are the A3 Digital IF or the A4 CPU. It is difficult to separate these two assemblies given the architecture of the analyzer. Each assembly will have to be tried to see which one is causing the failure.



## ≥ 85 MHz BW IF Section

### A25 Wideband Analog IF Assembly Description

The analyzer's RF input signal is down converted to a 300 MHz intermediate frequency by the A13 Front End assembly and routed through the A15 Front End controller to A15J901. Cable W53 connects A15J901 to the input of the A25 Wideband Analog IF at J101. The signal is filtered, attenuation and gain applied based upon the instrument settings. This signal is then sampled by the ADC and the resultant data is sent to the A26 Wideband Digital IF for processing via the J2 ribbon cable. The A26 Wideband Digital IF has no service accessible locations and should be troubleshot from the front panel controls.

#### Inputs to the A25 Assembly

- A25J101 300 MHz IF signal (from A15J901 Front End Controller)
- A25J301 2400 MHz reference from A16 Reference Assembly via W34 cable
- A25J805 Step Calibrator from A3J17 40 MHz Digital IF via W45 cable

#### Outputs from the A25 Assembly

- A25J302 2400 MHz Reference Out
- A25J102 300 MHz IF Out to A3J15 of the 40 MHz Digital IF
- A25J806 50 MHz Comb Out to A16 Reference assembly A16J726 via W56 cable
- A25J2 ADC Data to 140 MHz Digital IF A26J504 via W44 cable

### A25 Wideband Analog IF Assembly Theory of Operation

The A25 Wideband Analog IF assembly primary role is to properly filter and apply attenuation or gain to optimize the level going to the ADC and provide sufficient pre-filtering to reject images that would otherwise interfere with the signal of interest. Precision alignments are used to calibrate the filters, attenuators and gain of this assembly. It is not uncommon that the reported failure will come from failures reported when an alignment fails for this assembly. The alignment history file is a good indicator of a failure for this assembly. This file is a text file that can be edited with Notepad. The file is located in the following location:

E:\AlignDataStore\AlignmentHistory.txt

This file will list all alignments that have passed or failed. Alignments reporting a failure of the WBAIF assembly can in many cases be attributed to failure of this assembly. If however these errors follow errors in the RF section of the instrument, it is possible that additional WBAIF error will appear due to missing RF Calibration signals and not related to the A25 Wideband IF assembly.

Analog/Digital IF Troubleshooting  
≥ 85 MHz BW IF Section

Manually troubleshooting the assembly is basically verifying the 300 MHz IF signal is present and at the proper level. In addition you will want to verify input and output levels of the various calibration and reference signals.

Additionally, the A25 Analog IF has a built in RF Burst Trigger that is available when either the 85 MHz, 125 MHz, 140 MHz, or 160 MHz IF path is selected

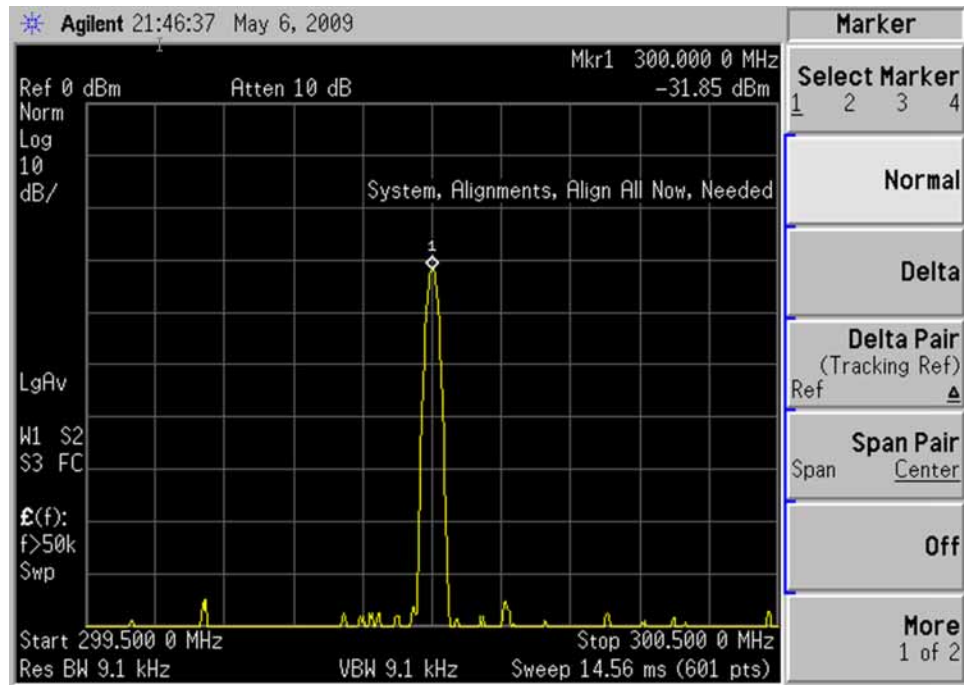
## A25 Wideband Troubleshooting

### Verify the 300 MHz IF Input level

1. Turn the instrument off.
2. Remove the instrument cover. Refer to [Chapter 14, “Assembly Replacement Procedures”](#) in this service guide.
3. Turn on the N9020A Signal Analyzer and wait for the instrument to complete the boot up process.
4. Press **System, Alignments, Auto Align, Off**.
5. Press **Mode, IQ Analyzer**
6. Press **Meas, Complex Spectrum**
7. Press **Input/Output, RF Calibrator, 50 MHz**
8. Press **Mode Setup, IF Path, 85, 120, or 140 MHz**
9. Verify the 50 MHz signal is at –25 dBm on the analyzer display by pressing **FREQ, 50 MHz, SPAN, 1 MHz, Peak Search** on the N9020A. The marker readout should be 50 MHz at –25 dBm  $\pm$ 3 dB. If this reference signal is measuring incorrectly, see [Chapter 4, “RF Section Troubleshooting”](#) in this service guide.
10. Connect A25J02 to a known good spectrum analyzer. Tune the spectrum analyzer to 300 MHz. This port switches the 300 MHz IF that is input to the A25 Wideband Analog IF to be routed to the A3J16 40 MHz Digital IF. If

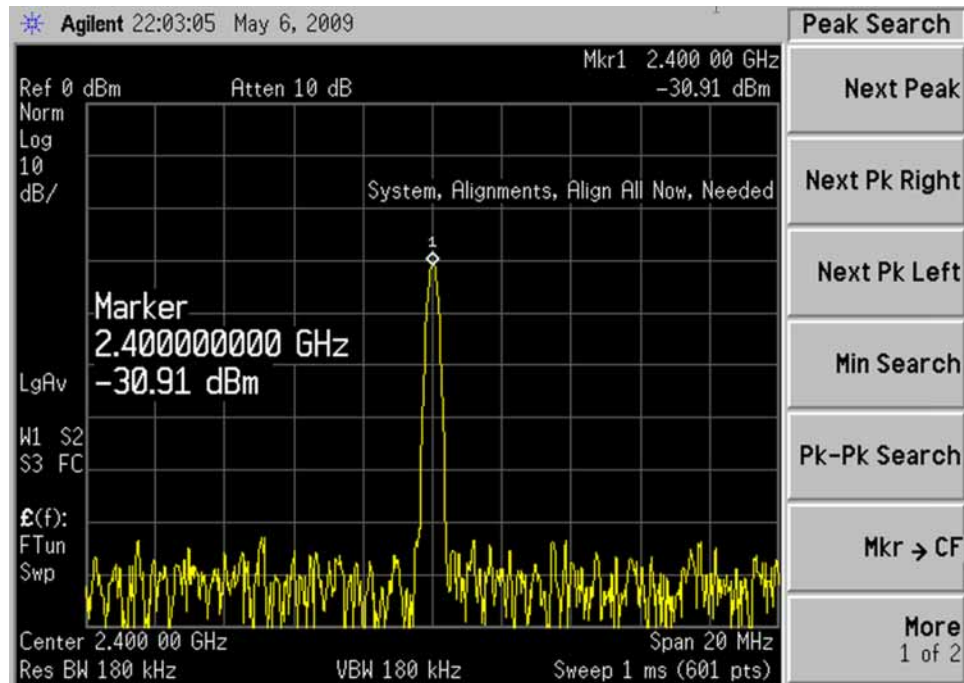
Analog/Digital IF Troubleshooting  
≥ 85 MHz BW IF Section

this  $-30 \text{ dBm} \pm 3 \text{ dB}$  signal is present, you have verified the 300 MHz IF from the A15J901 Front End Controller. If this signal is not present, verify the signal is present on A15J901 of the A15 Front End Controller.



### Verify the 2400 MHz Frequency Reference

1. Turn the instrument off.
2. Remove the instrument cover. Refer to [Chapter 14, “Assembly Replacement Procedures”](#) in this service guide.
3. Turn on the N9020A Signal Analyzer and wait for the instrument to complete the boot up process.
4. Press **System, Alignments, Auto Align, Off**.
5. Press **Mode, IQ Analyzer**
6. Press **Meas, Complex Spectrum**
7. Press **Input/Output, RF Calibrator, 50 MHz**
8. Press **Mode Setup, IF Path, 85, 125, or 140 MHz**
9. Verify the 50 MHz signal is at  $-25$  dBm on the analyzer display by pressing **FREQ, 50 MHz, SPAN, 1 MHz, Peak Search** on the N9020A. The marker readout should be 50 MHz at  $-25$  dBm  $\pm 3$  dB. If this reference signal is measuring incorrectly, see [Chapter 4, “RF Section Troubleshooting”](#) in this service guide.
10. Connect a known good spectrum analyzer to A25J302. Verify reference signal at 2400 MHz at a level of  $-30$  dBm.



## A26 140 MHz Wideband Digital IF Troubleshooting

### Verify the 300 MHz IF Input level

The A26 Digital IF has a single accessible input at A25J2. It is not advisable to disconnect this cable and make measurements. Normally failure of this assembly will occur during extensive alignments. Verify if there are alignment error related to the WBDIF located in the E:\AlignDataStore\AlignmentHistory.txt files.

If errors are found related to WBDIF replace the A26 Wideband Digital IF assembly. To troubleshoot this module set the instrument up as below:

1. Turn on the N9020A Signal Analyzer and wait for the instrument to complete the boot up process.
2. Press **System, Alignments, Auto Align, Off**.
3. Press **Mode, IQ Analyzer**
4. Press **Meas, Complex Spectrum**
5. Press **Input/Output, RF Calibrator, 50 MHz**
6. Press **Span, 10 MHz**
7. Press **Mode Setup, IF Path, 85, 125, or 140 MHz**
8. Verify the 50 MHz signal is at -25 dBm on the analyzer display by pressing **Peak Search** on the N9020A. The marker readout should be 50 MHz at -25 dBm ±3 dB.
9. If this signal is not present, determine if the issue is only present with the Wideband 85, 125, or 140 MHz path. Press **Mode Setup, IF Path, 40 MHz**. If the signal is now present, there is a likely failure of the A26 Wideband Digital IF or the A25 Wideband Analog IF

## 7 L.O. Synthesizer/Reference Troubleshooting

### What You Will Find in This Chapter

The following information is found in this chapter:

**A14 L.O. Synthesizer Assembly Description on page 280**

**A14 L.O. Synthesizer Theory of Operation on page 281**

**A14 L.O. Synthesizer Troubleshooting on page 282**

**A16 Reference Assembly Description on page 290**

**A16 Reference Assembly Troubleshooting on page 293**

## A14 L.O. Synthesizer Assembly Description

### Purpose

The L.O. Synthesizer assembly provides the 1st Local Oscillator to the A13 RF Front End Assembly for RF conversion. This assembly has the following inputs and outputs:

- Power Supply inputs
- Serial Bus input for L.O. Control
- Sweep input for L.O. Control
- 4800 MHz input signal from A16 Reference Assembly
- 1st L.O. output signal to A13 RF Front End Assembly

The input signal to the L.O. Synthesizer Assembly is a 4800 MHz signal that is generated on the A16 Reference Assembly. The 1st L.O. is then phase locked to this 4800 MHz reference, which is then phase locked back to the 10 MHz reference located on the A16 Reference Assembly. The quality of the phase lock design that locks the 1st L.O. has a direct relationship on the overall stability of the analyzer. Users can also provide their own external reference. The frequency accuracy of the user frequency reference is directly related to the overall frequency accuracy of the signal analyzer.

The 1st L.O. has a tuning range from 3.8 GHz to 8.7 GHz and an output power from +13 to +18 dBm. The RF input signal mixes with the 1st L.O. in one of three possible mixers on the RF Front End Assembly. For more detailed description on the RF Front End Assembly, see **Chapter 4, “RF Section Troubleshooting”** in this service guide.



## A14 L.O. Synthesizer Theory of Operation

The main oscillator is a low frequency Voltage Controlled Oscillator (VCO) that has a frequency range from 570 MHz to 1150 MHz. This VCO has low-phase noise that is multiplied to the desired 1st LO frequency range.

This VCO/Multiplier technology uses built-in filters after each multiplier to suppress the undesired harmonics. The resultant output has enough power with a wide enough frequency range to measure RF input signals up to 26.5 GHz.

### Brief Description of the Major Blocks:

- The Field Programmable Gate Array (FPGA) L.O. Controller has the capability to perform automatic pretune update, unlock detection, reference signal phase adjustment, and automatic segment sequencing using block RAM and its segment state machine.
- The fractional-N divider performs frequency division of the feedback VCO signal.
- The VCO is a low noise, voltage control oscillator multiplied up to the actual LO frequency. This wide-band oscillator features isolated input ports, allowing the main tune port and the FM tune port to be formed. It has more than an octave of tuning range with relatively flat tuning sensitivity.
- The LO Multiplier is a frequency multiplier with switched filters and amplifiers to produce the required output frequency.

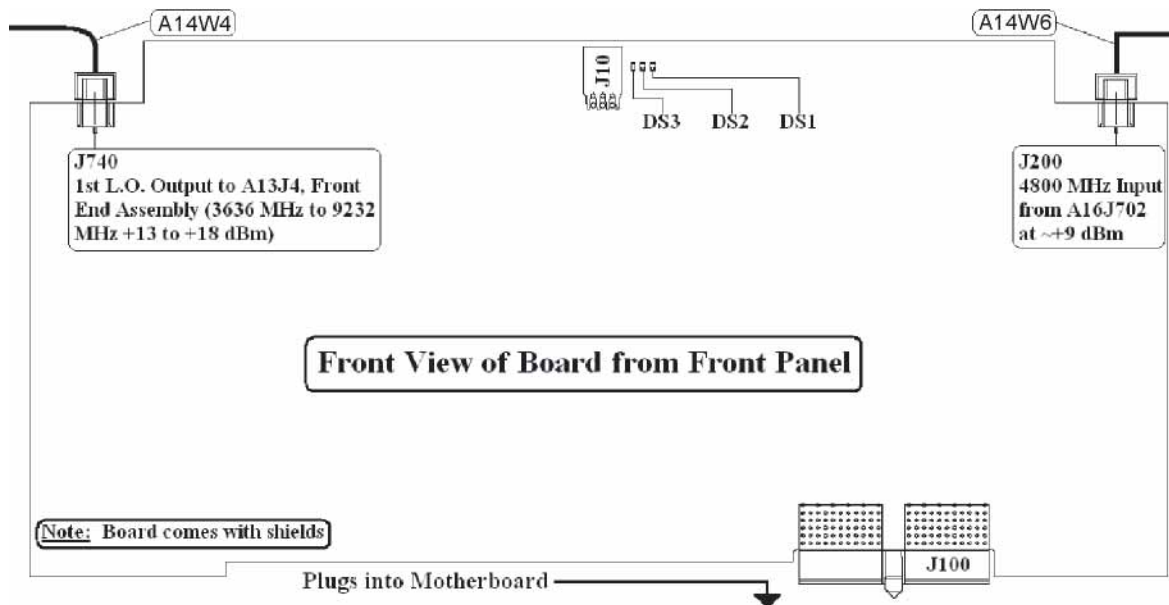
## A14 L.O. Synthesizer Troubleshooting

Turn on the analyzer and wait for the instrument to complete the boot up process. There are (6) processes to perform, which will verify the L.O. Synthesizer Assembly is functioning properly:

- Press **Freq, 50 MHz, SPAN, Zero Span**. LED's DS1-DS3 located near the top of the board next to J10 should all be off. See LED location in **Figure 7-1** below.
- Press **System, Alignments, Align Now, All**. If the alignment functions correctly with no error messages on the analyzer display, most of the board is working properly.
- Measure 4800 MHz Input frequency (from A16 Reference Assembly)
- Measure 4800 MHz Input Power (from A16 Reference Assembly)
- Measure L.O. Output Power.
- Measure L.O. Output Frequency.

These items can be checked with a functioning spectrum analyzer using cables and connectors that function well up to 10 GHz.

Figure 7-1 A14 L.O. Synthesizer Assembly



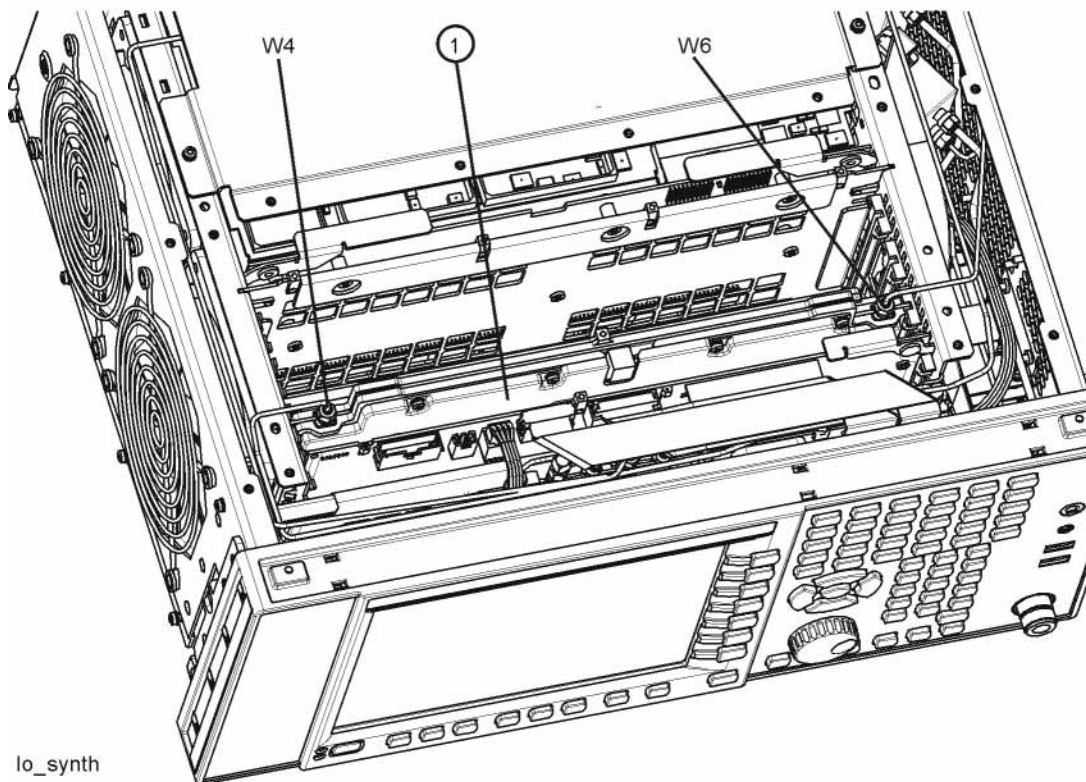
### Verifying the 4800 MHz Input Power & Frequency Stability:

- Turn on the analyzer and wait for the instrument to complete the boot up process.
- Press **FREQ, 4.2 GHz, SPAN, Zero Span**.
- Disconnect A14W6 cable at A14J200 (see **Figure 7-2**).

**NOTE** DS2 and DS3 will illuminate when the W6 cable is removed. This is normal.

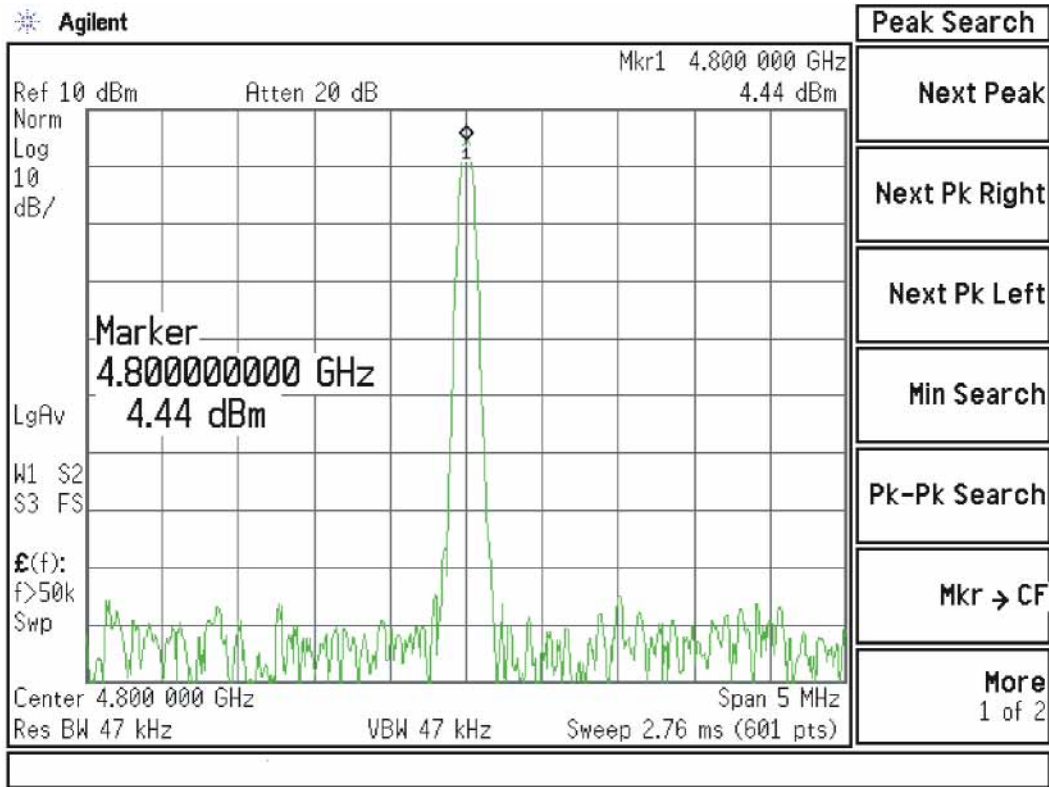
- Connect A14W6 cable end to the RF input of the functioning spectrum analyzer.

Figure 7-2 W4 and W6 Location



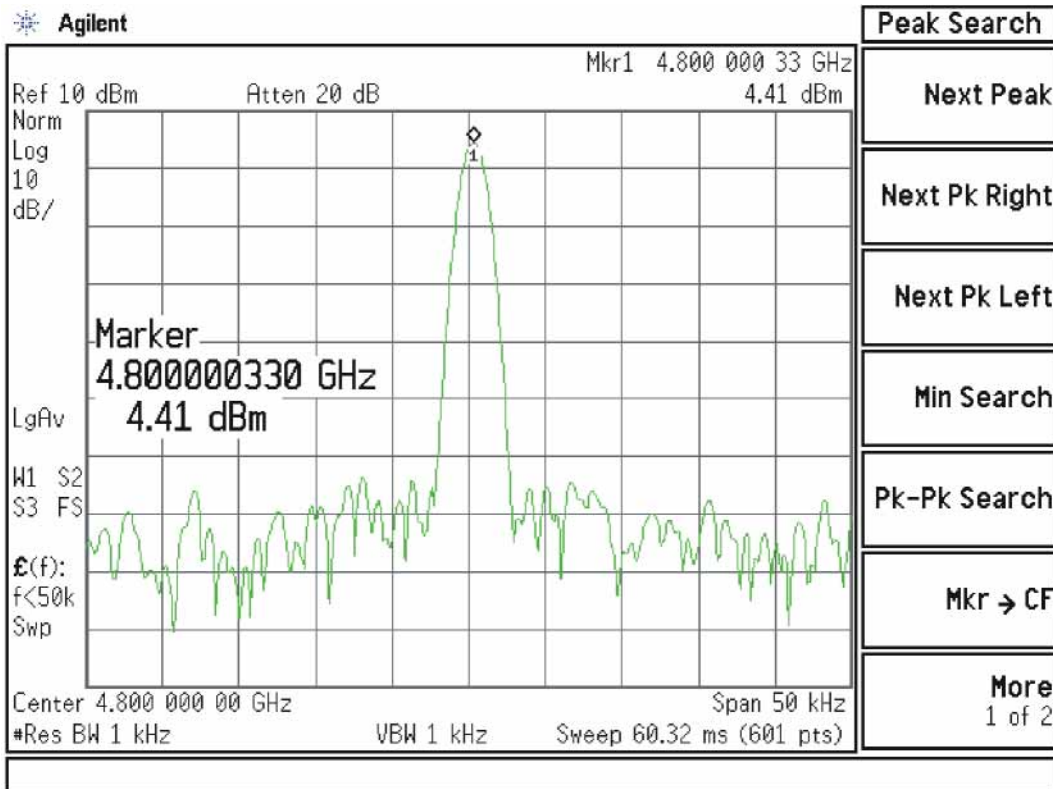
- The analyzer marker should read 4800 MHz at +4.5 dBm  $\pm$  2 dB as shown in **Figure 7-3**.

Figure 7-3 4800 MHz Wide Span



- Verify the 4800 MHz input signal from the A16 Reference Assembly is stable by pressing **SPAN, 50 kHz, BW, 1 kHz**. The signal on the functioning spectrum analyzer should be very stable both in frequency and power as shown in **Figure 7-4**.
- Reconnect the W6 cable to A14J200.

Figure 7-4 4800 MHz Narrow Span

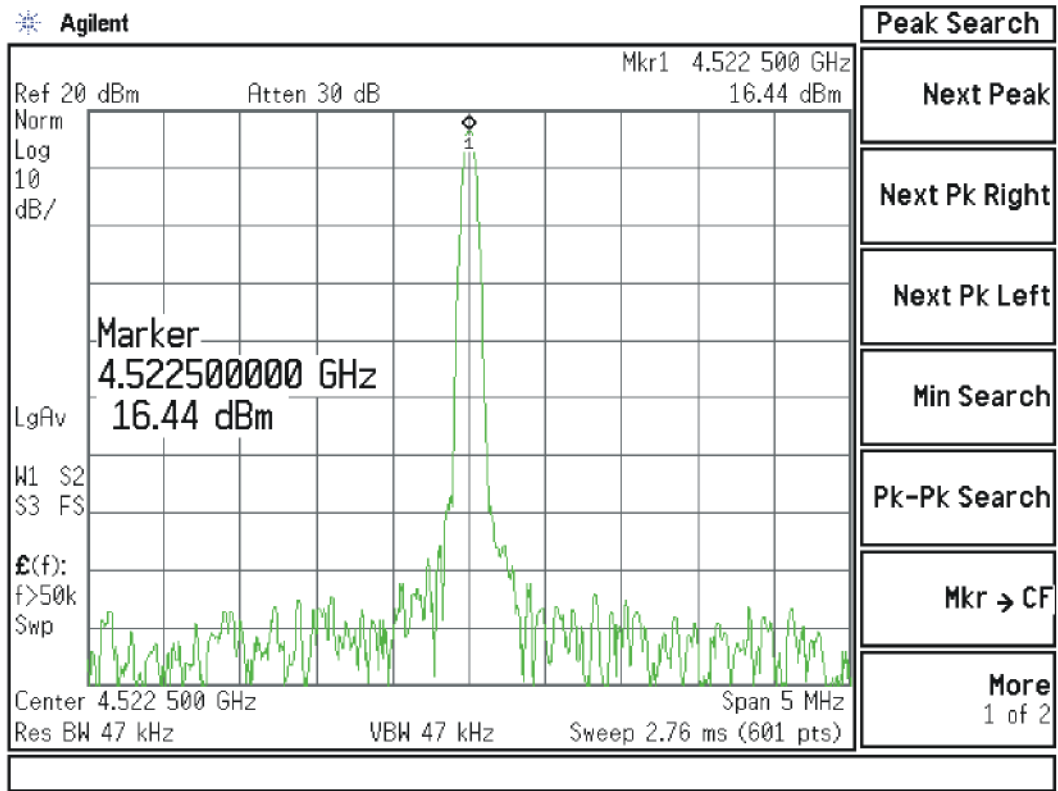


**NOTE** If the 4800 MHz signal is not measuring the correct power level, see the **"A16 Reference Assembly Troubleshooting"** section later in this chapter.

### Verifying the 1st L.O. Output Power:

- Turn on the analyzer and wait for the instrument to complete the boot up process.
- If the analyzer has Option 503, press **FREQ, 600 MHz, Span, Zero Span**.  
If the analyzer does not have Option 503 press **FREQ, 4.2 GHz, SPAN, Zero Span**.
- Refer to **Figure 7-1**, disconnect A14W4 cable at A14J740.
- Connect A14J740 1st LO output to the RF input of the functioning spectrum analyzer using a cable that will function up to 10 GHz.
- Press **Frequency, 4.5225 GHz** (if the analyzer does not have Option 503) or **Frequency 5.7225 GHz** (if the analyzer has Option 503), **Span, 5 MHz, Peak Search** on the functioning spectrum analyzer. If the functioning spectrum analyzer has a preselector peak or preselector centering function, perform that operation to guarantee the preselector is optimized for the measurement.
- The analyzer marker should read 4.5225 GHz or 5.7225 GHz at +16.55 dBm  $\pm$  3 dB as shown in **Figure 7-5**.

Figure 7-5 4.5225 GHz 1st L.O. Measurement



**NOTE** If the 4.5225 GHz or 5.7225 GHz signal is not measuring the correct power level, the LO Synthesizer assembly is the most probable cause.

Continue changing the center frequency of the analyzer as per [Table 7-1](#) and measure the LO output expected frequency and power using the functioning spectrum analyzer.

**NOTE** Perform the preselector peak or preselector centering on the functioning spectrum analyzer if any of the expected 1st L.O. power levels are not within tolerance.

Table 7-1

Center Frequency of analyzer (MHz)	Expected 1st L.O. Frequency (GHz) @A14J704	Expected 1st L.O. Power (dBm) @A14J704
4200 <sup>a</sup>	4.5225	+16.5 ± 3 dB
4300 <sup>a</sup>	4.6225	+16 ± 3 dB
600	5.7225	+16 ± 3 dB
700	5.8225 (see <b>Figure 7-6</b> )	+16 ± 3 dB
2100	7.2225	+16 ± 3 dB
2200	7.3225 (see <b>Figure 7-7</b> )	+16 ± 3 dB

a. Does not apply to analyzers with Option 503.



Figure 7-6 5.8225 GHz 1st L.O. Measurement

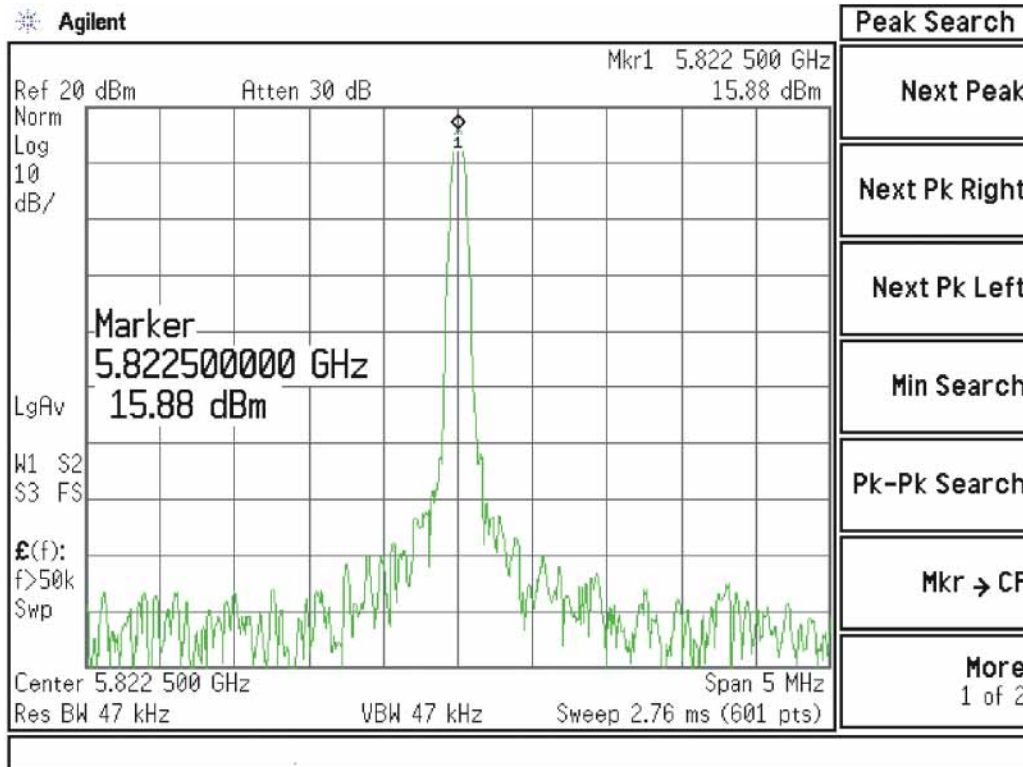
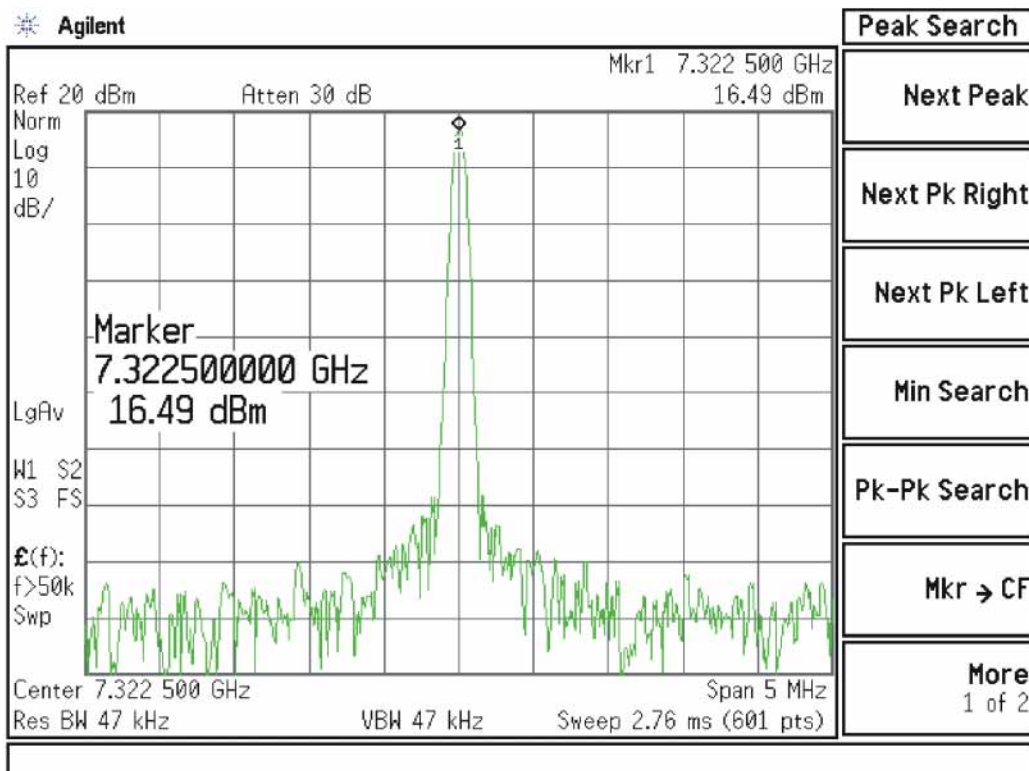


Figure 7-7 7.3225 GHz 1st L.O. Measurement



## A16 Reference Assembly Description

### Purpose

The A16 Reference Assembly provides the fundamental reference signals from which all instrument local oscillator and synchronous timing signals are derived. The reference board also uses these same signals to generate CW and modulated RF calibration signals and a 10 MHz time base signal for the instrument.

For analyzers with serial prefixes  $\geq$  MY/SG/US5233, or any with Option B85, B1A, or B1X the Reference assembly must be replaced as a single assembly, although it is constructed of two boards, the A16 Reference Main board and A16A1 Reference Daughter board. These boards are listed individually in the Show Hardware screen, allowing identification of the individual board part numbers comprising the complete assembly.

The reference signals and local oscillators can be phase locked to a timebase in one of two ways:

1. **The internal 10 MHz reference located on the A16 Main Board.**
2. **An externally provided reference such as a house standard or the reference from another instrument or a base transceiver system. The external reference can be any RF signal in the range of 1 MHz to 50 MHz, -5 dBm to +10 dBm.**

If an external reference signal is within 200 Hz of the specified external reference frequency and **Freq Ref In** is set to **Sense**, the analyzer will automatically switch from SENSE:INT to SENSE:EXT.

The frequency accuracy of the analyzer is directly tied to the accuracy of the frequency reference that is being used.

Diagnostic LEDs monitor the status of the various PLLs on the A16 Reference Assembly.

Table 7-2 A16 Reference Assembly Signals

Signal Description	From Location	Originates From	To Location	Purpose
External Reference Input (1 to 50 MHz, -5 dBm to +10 dBm)	Input from User	n/a	A16704	Phase Lock analyzer with user reference.
10 MHz Out DIF	A16J710	10 MHz Reference	A3J14 <sup>a</sup>	Used as a reference to other assemblies throughout the instrument.
50 MHz Align Signal	A16J701	100 MHz VCXO/2	A9, Cal Signal Input, Input Attenuator A.	50 MHz Low band alignment signal.
4800 MHz Align Signal	A16J701	2.4 GHz VCXO x 2 or 100 MHz VCXO x 48	A9, Cal Signal Input, Input Attenuator A.	4.8 GHz High band alignment signal
50 MHz Ecal/300 MHz Comb Output	A16J705	100 MHz VCXO/2, 100 MHz VCXO x 3	A13J6, RF Front End Assembly	50 MHz Cal Signal or 300 MHz Comb for wideband I.F. phase linearity
100 MHz 1st LO	A16J706	100 MHz VCXO	A3J14 <sup>b</sup>	Used as a reference to other assemblies throughout the instrument.
100 MHz Ref A	A16J707	100 MHz VCXO	Not used	Reserved for future use.
100 MHz Ref B	A16J716	100 MHz VCXO	A3J14 <sup>c</sup>	Frequency reference for A3 Digital IF (DIF) assembly. Divided by 10 on DIF to provide 10 MHz OUT on rear panel.
100 MHz Ref C <sup>d</sup>	A16J707	100 MHz VCXO	Not used	Reserved for future use.
300 MHz LO AIF	A16J711	100 MHz VCXO x 3	A2J300	Used as 3rd LO on A2 Analog IF (AIF) assembly
2.4 GHz Ref	A16J718 <sup>d</sup> or A16J715 <sup>e</sup>	2.4 GHz VCXO or 100 MHz VCXO x 24	A25J301	Reference for A25 Wideband Digital IF (WDIF)
4.8 GHz 2nd LO	A16J702	2.4 GHz VCXO x 2 or 100 MHz VCXO x 48	A13J1	2nd LO for A13 Front End assembly, downconvert low band 1st IF to 322.5 MHz 2nd IF

Table 7-2 A16 Reference Assembly Signals

Signal Description	From Location	Originates From	To Location	Purpose
4.8 GHz 1st LO Ref	A16J703	2.4 GHz VCXO x 2 or 100 MHz VCXO x 48	A14J4	4GHz reference for Offset Loop, only used in Dual-Loop operation

- a. The 10 MHz signal from A16J713 is used a reference for the standard A3 Digital IF, which supports analysis bandwidths up to 25 MHz.
- b. The 100 MHz signal from A16J706 is used as the reference for the optional A3 Digital IF which supports analysis bandwidths up to 40 MHz on analyzers with serial prefix < MY/SG/US5233. This A3 is used on analyzers with Options B40, MPB, or DP2.
- c. The 100 MHz signal from A16J716 is used as the reference for the optional A3 Digital IF which supports analysis bandwidths up to 40 MHz on analyzers with serial prefix  $\geq$  MY/SG/US5233. This A3 is used on analyzers with Options B40, B85, B1A, B1X, MPB, or DP2.
- d. Serial prefix  $\geq$  MY/SG/US5233 or any with Option B85, B1A, or B1X.
- e. Serial prefix < MY/SG/US5233 and none of the following options; B85, B1A, or B1X.

## A16 Reference Assembly Troubleshooting

**NOTE** In order to measure signals on analyzers with serial prefix < MY/SG/US5233, you will need to remove the rear panel. Refer to “Rear Panel” removal procedure on [page 486](#) for details.

---

If the A16 Reference Assembly is suspect, verify the reference signals, local oscillator output frequencies, and power levels as per [Table 7-2](#) using a functioning spectrum analyzer.

The board layout in [Figure 7-8](#), [Figure 7-9](#), and [Figure 7-10](#) (depending on serial prefixes) below identifies the input and output connectors and LEDs on the A16 Reference Assembly.

If these outputs measure correctly, the A16 Reference Assembly is functioning correctly. If not, the Reference Assembly is the most probable cause provided the power supply is operating correctly. Refer to “[A7 Midplane Assembly Troubleshooting](#)” on [page 327](#) if the power supplies are suspect.

Figure 7-8 A16 Reference Assembly, Serial Prefix > MY/SG/US/5233

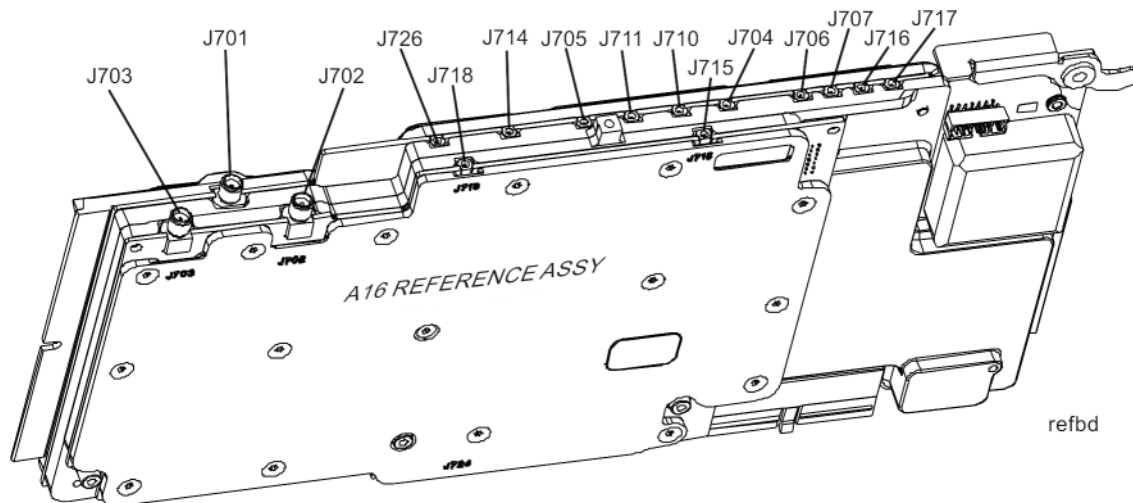


Figure 7-9 A16 Reference LEDs, Serial Prefix > MY/SG/US5233

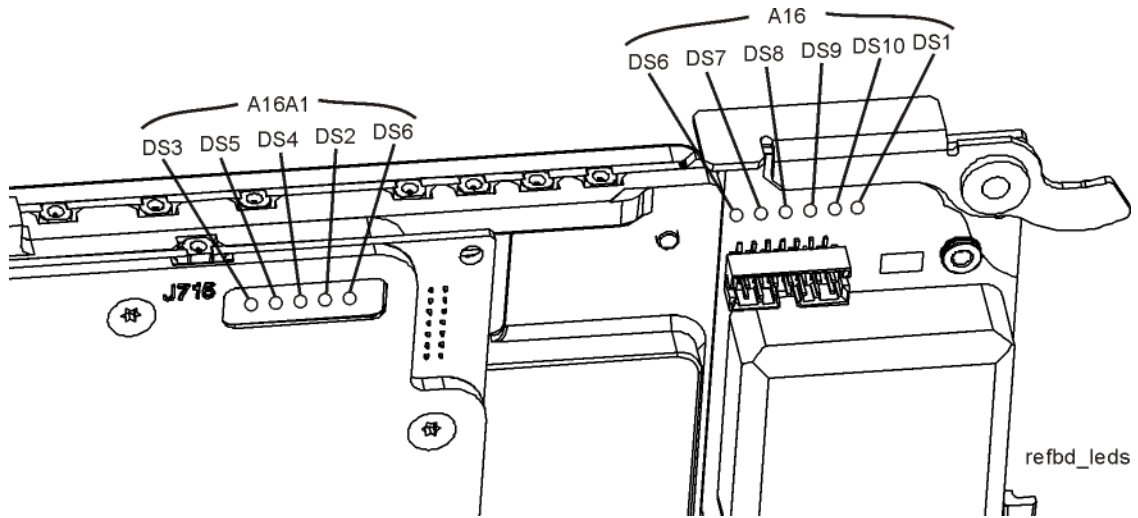


Figure 7-10 A16 Reference Assembly Layout, Serial Prefix < MY/SG/US5233

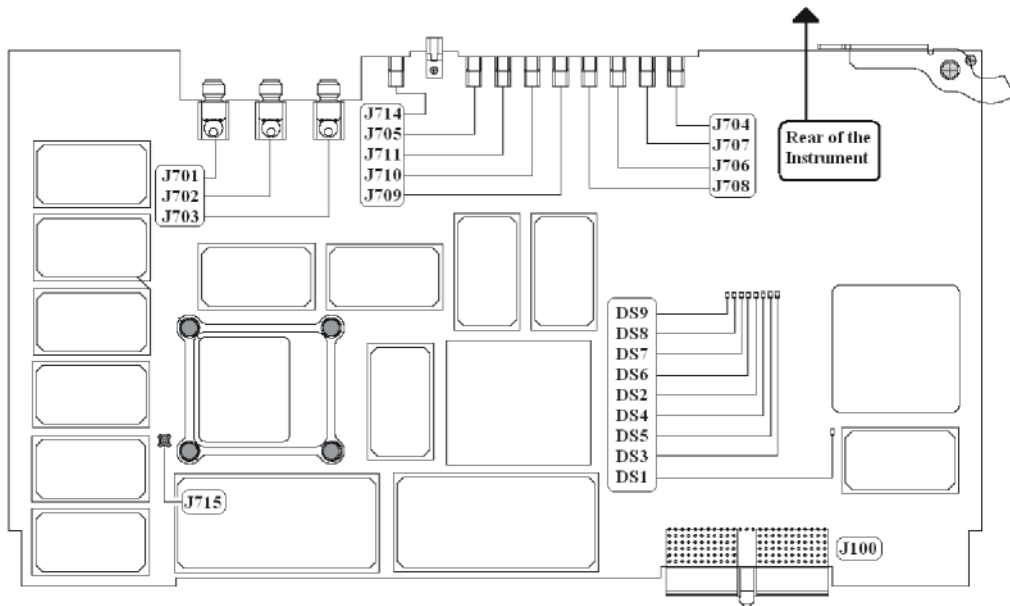


Table 7-3 A16 Reference Assembly Signal Measurement Details

Signal Description	Signal Location	Expected Frequency (MHz)	Expected Power Level (dBm)	Special Instrument Conditions	Figure
50 MHz Ecal Out	A16J705	50 MHz	-26 to -29 dBm typical	While monitoring A16J705 output, place functioning spectrum analyzer in Max Hold. Press <b>System, Alignments, Align Now, All</b> on MXA.	Figure 7-11
4.8 GHz 2nd LO Out	A16J702	4800 MHz	+10 dBm $\pm$ 2 dB	Press <b>Freq, 1 GHz, Span, Zero Span</b> on MXA	Figure 7-12
4.8 MHz 1st LO Ref Out	A16J703	4800 MHz	+4 dBm	Press <b>Freq, 50 MHz, Span, Zero Span, Meas Setup, PhNoise Opt, Best Close in PNoise</b> on MXA	Figure 7-13
50 MHz Ref Out	A16J701	50 MHz	-25 dBm	Press <b>Input/Output, RF Calibrator, 50 MHz</b> on MXA	Figure 7-14
4.8 GHz Ref Out	A16J701	4800 MHz	-28 dBm	Press <b>Input/Output, RF Calibrator, 4.8 GHz</b> on MXA	Figure 7-15
2.4 GHz Ref Out	A16J718	2400 MHz	+10 dBm <sup>a</sup> or -12.5 to -15.5 dBm <sup>b</sup>		Figure 7-16 or Figure 7-17
300 MHz LO AIF	A16J711	300 MHz	+10 dBm		Figure 7-18
100 MHz Ref Output <sup>b</sup>	A16J706	100 MHz	+13 dBm		Figure 7-19
100 MHz Ref B Out <sup>a</sup>	A16J716	100 MHz	+13 dBm		Figure 7-20
10 MHz Output <sup>c</sup>	A16J710	10 MHz	+7 dBm		Figure 7-21

- a. Use on units serial prefix  $\geq$  MY/SG/US5233 with any of the following options: B40, MPB, DP2 or any units with any of the following options: B85, B1A, B1X
- b. Used on units serial prefix  $<$  MY/SG/US5233 with any of the following options: B40, MPB, DP2 and without any of the following options: B85, B1A, B1X
- c. Used in units without any of the following options: B40, DP2, MPB

Figure 7-11 50 MHz Ecal Out

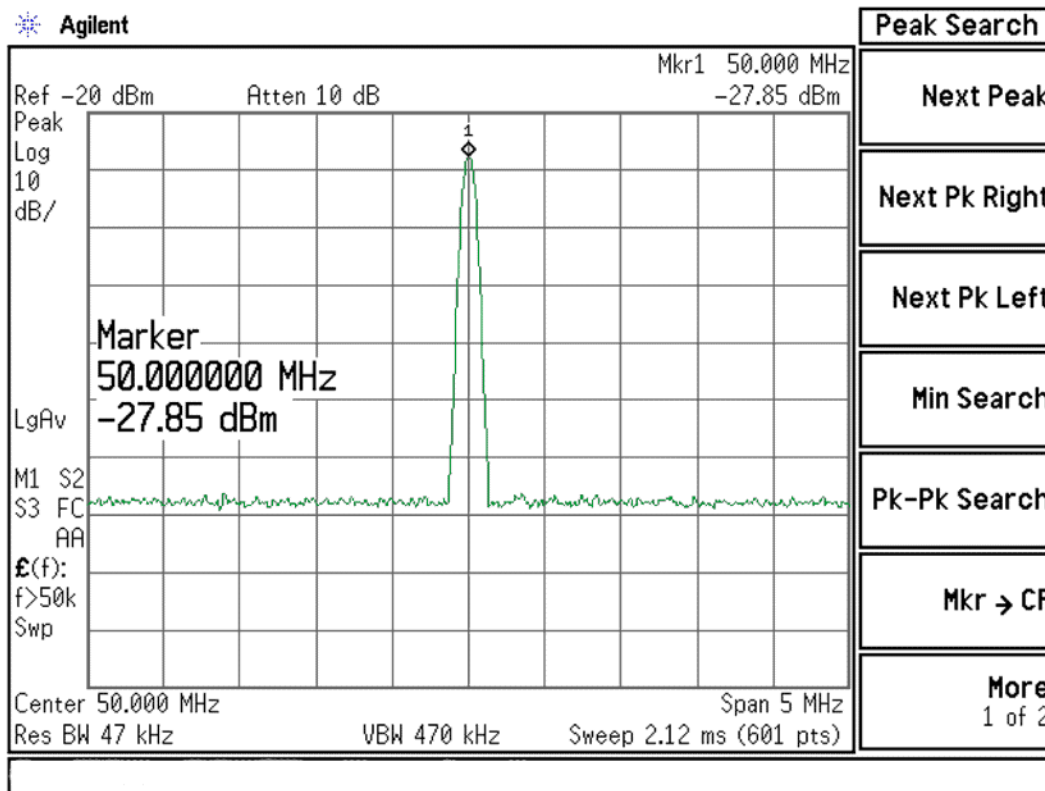


Figure 7-12 4.8 GHz 2nd LO Out

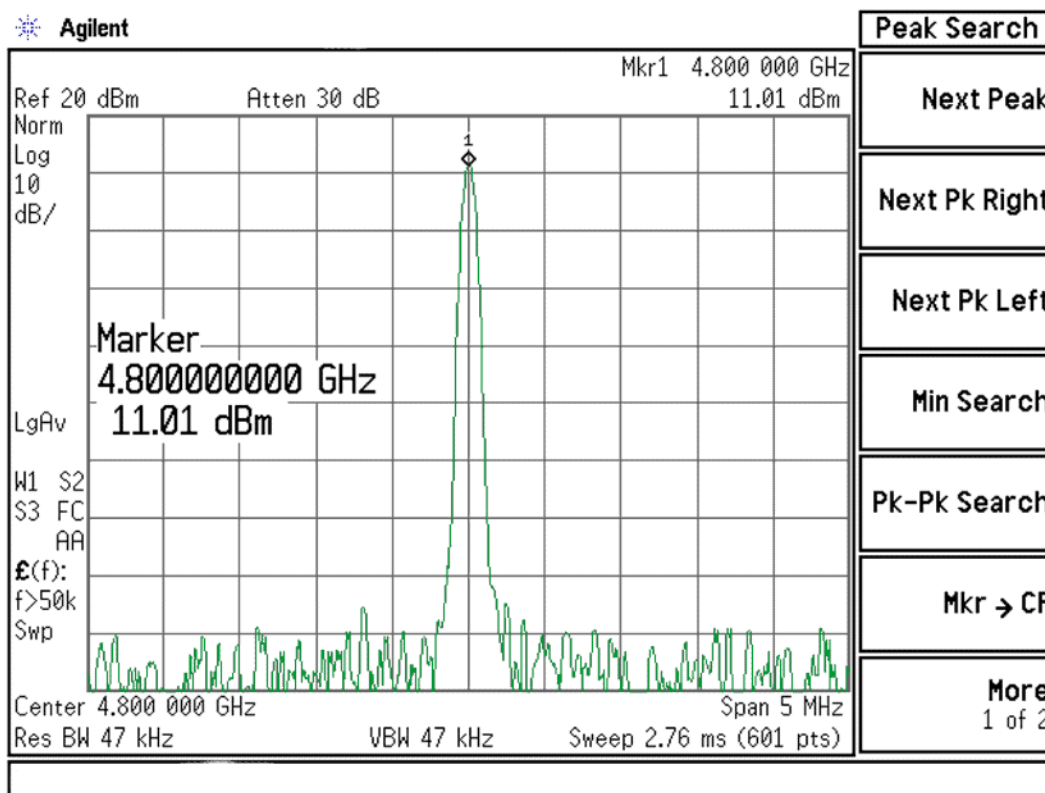




Figure 7-13 4.8 GHz 1st LO Ref Out

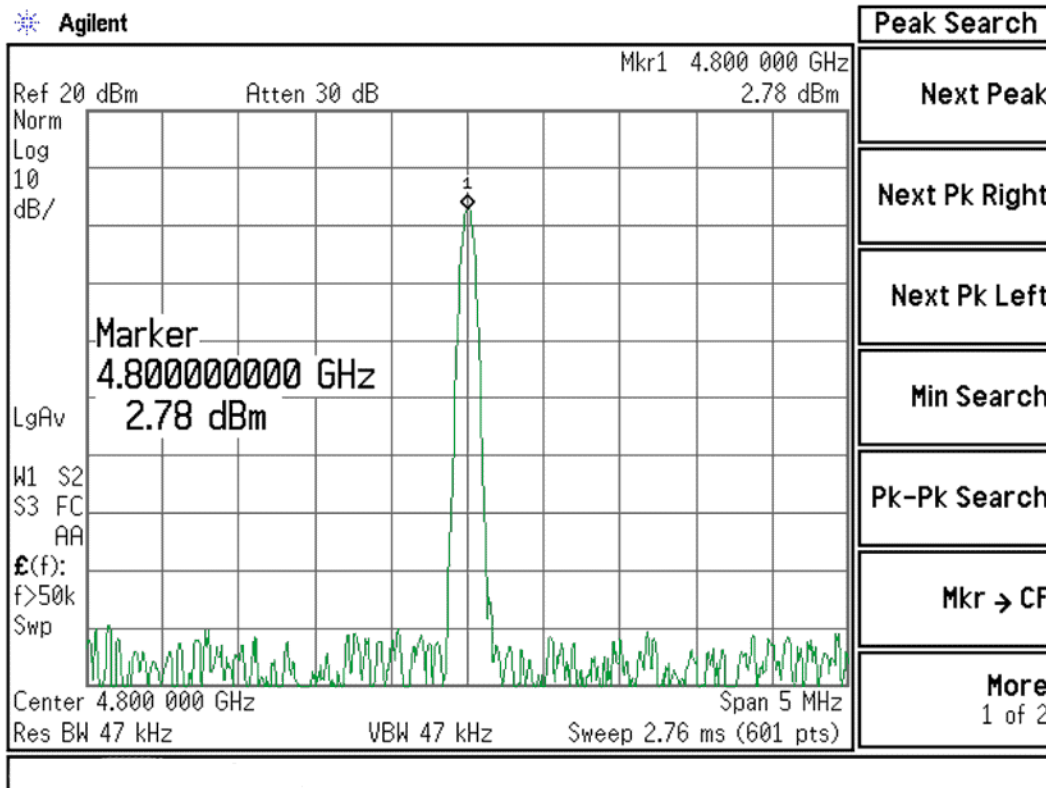


Figure 7-14 50 MHz Ref Out

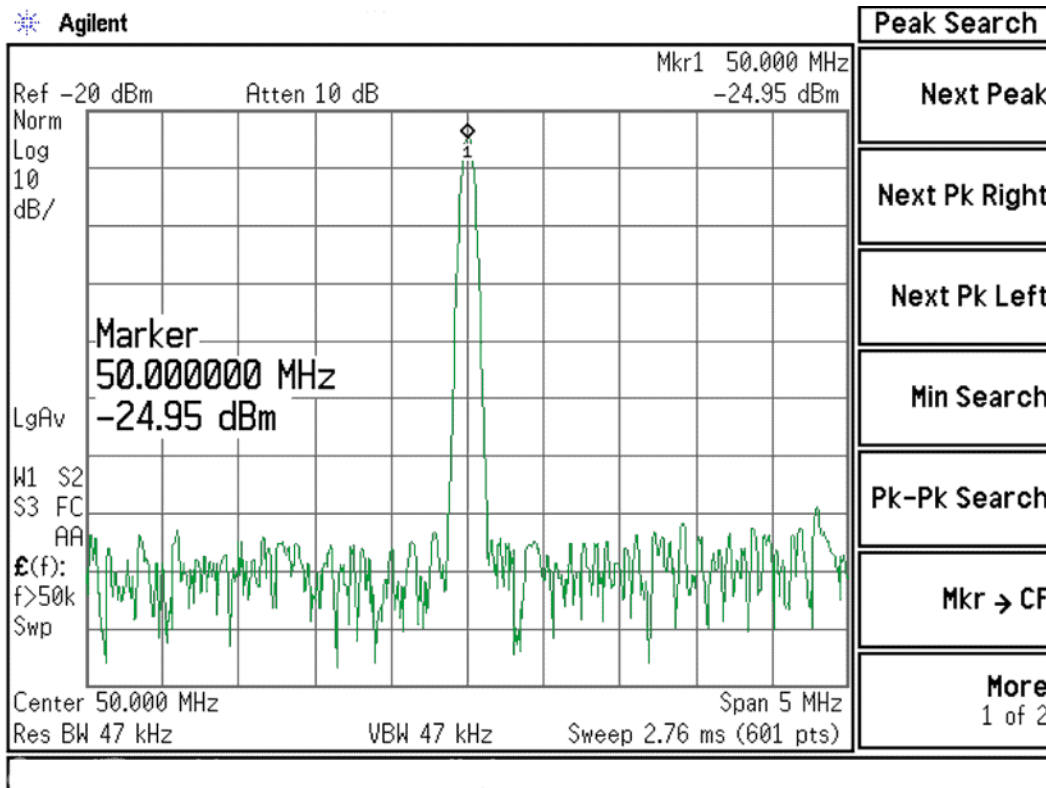


Figure 7-15 4.8 GHz Ref Out

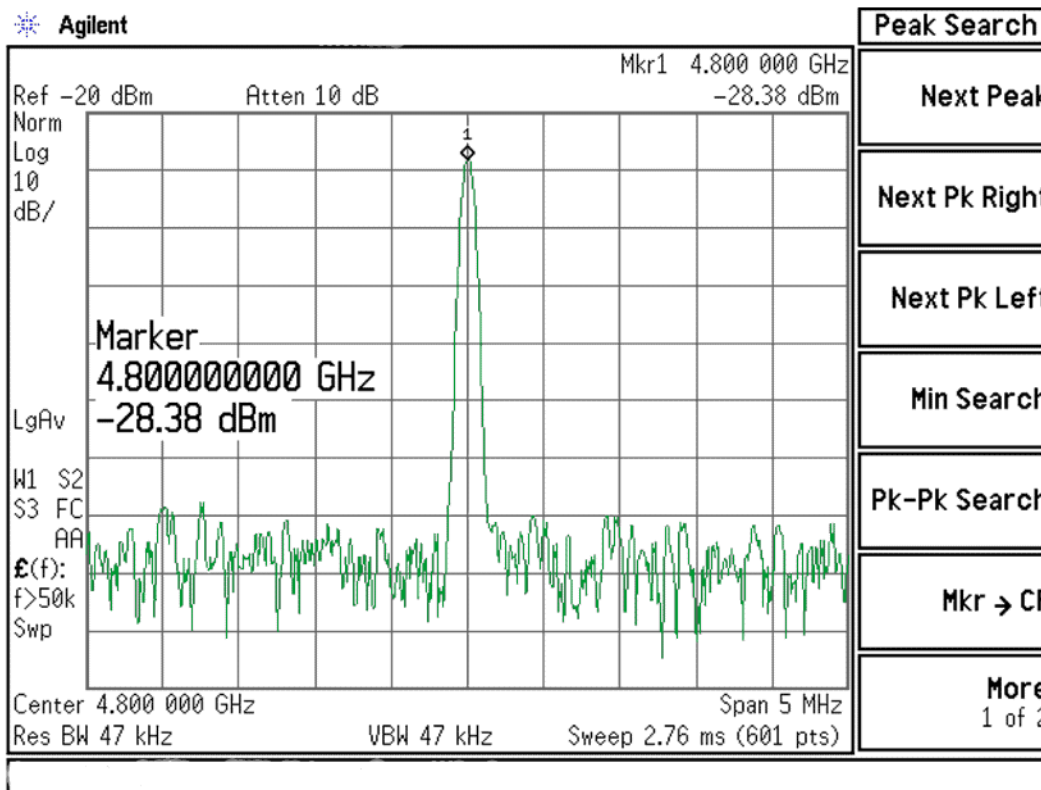


Figure 7-16 2.4 GHz Ref Output (Serial Prefix ≥ MY/SG/US5233)

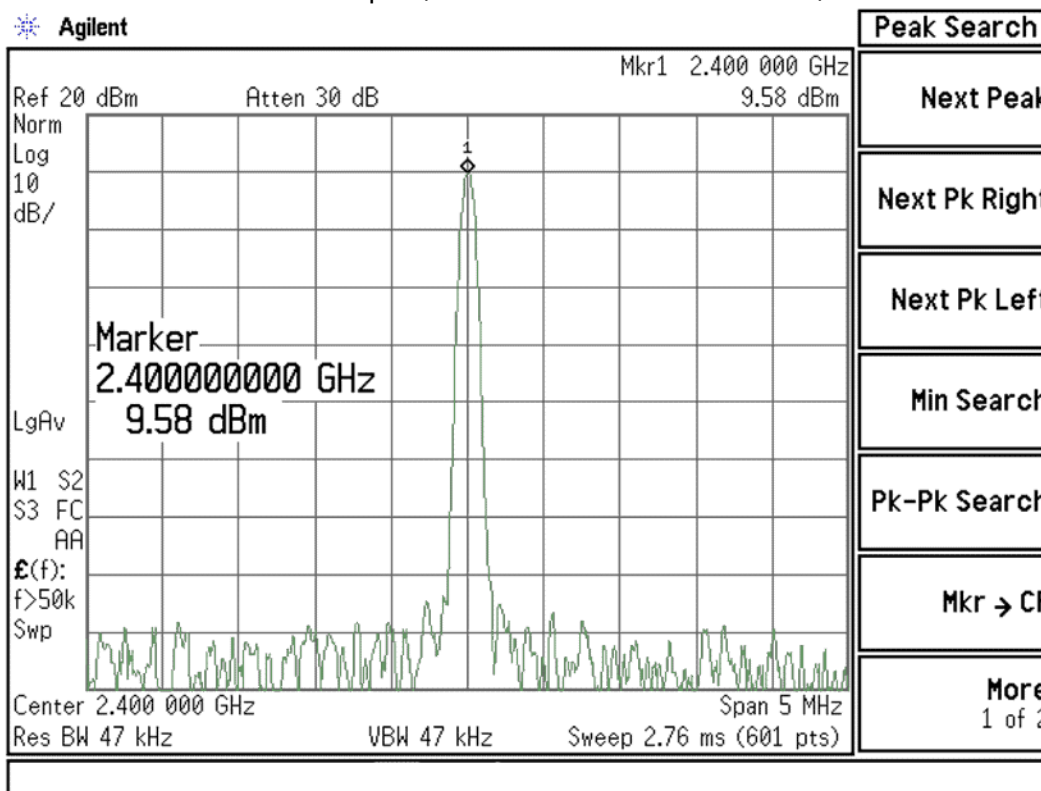


Figure 7-17 2.4 GHz Reference Out (Serial Prefix < MY/SG/US5233)

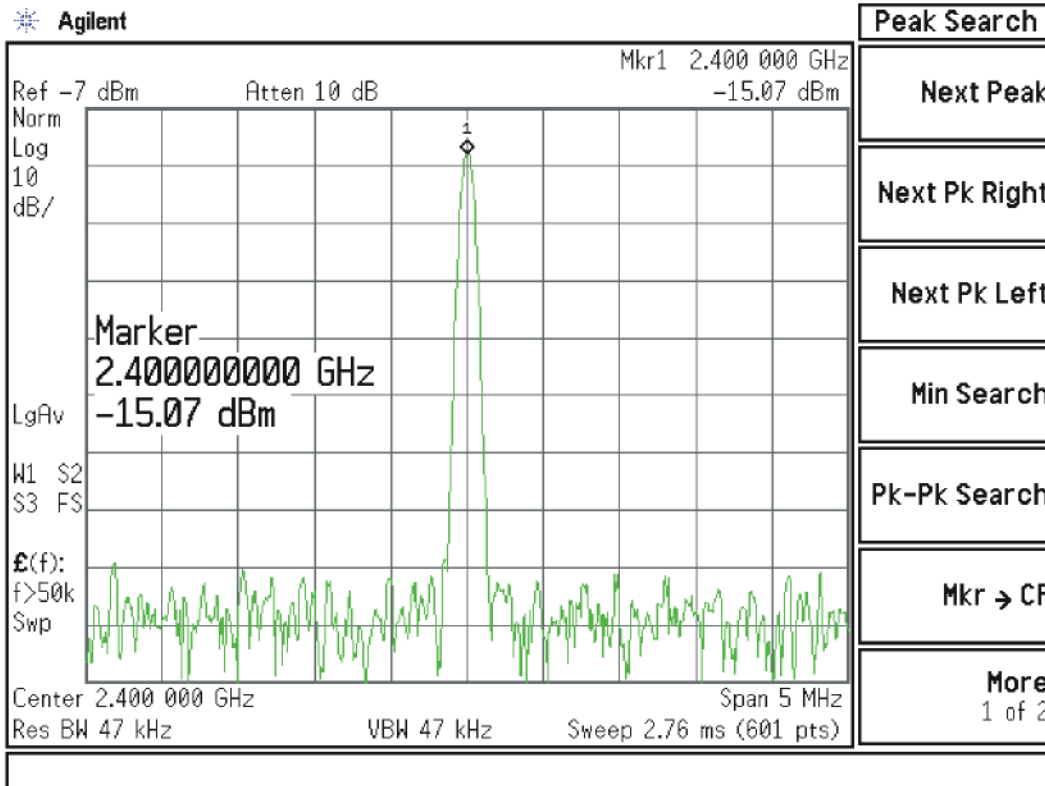


Figure 7-18 300 MHz LO AIF

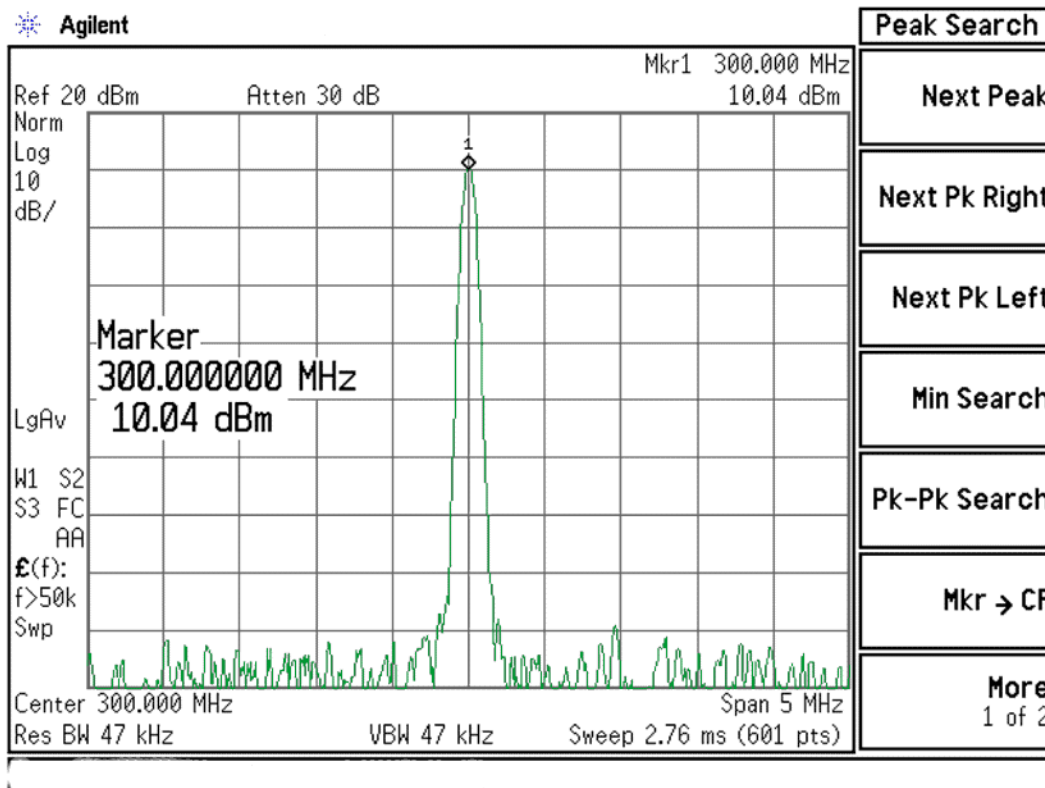


Figure 7-19 100 MHz Ref Out

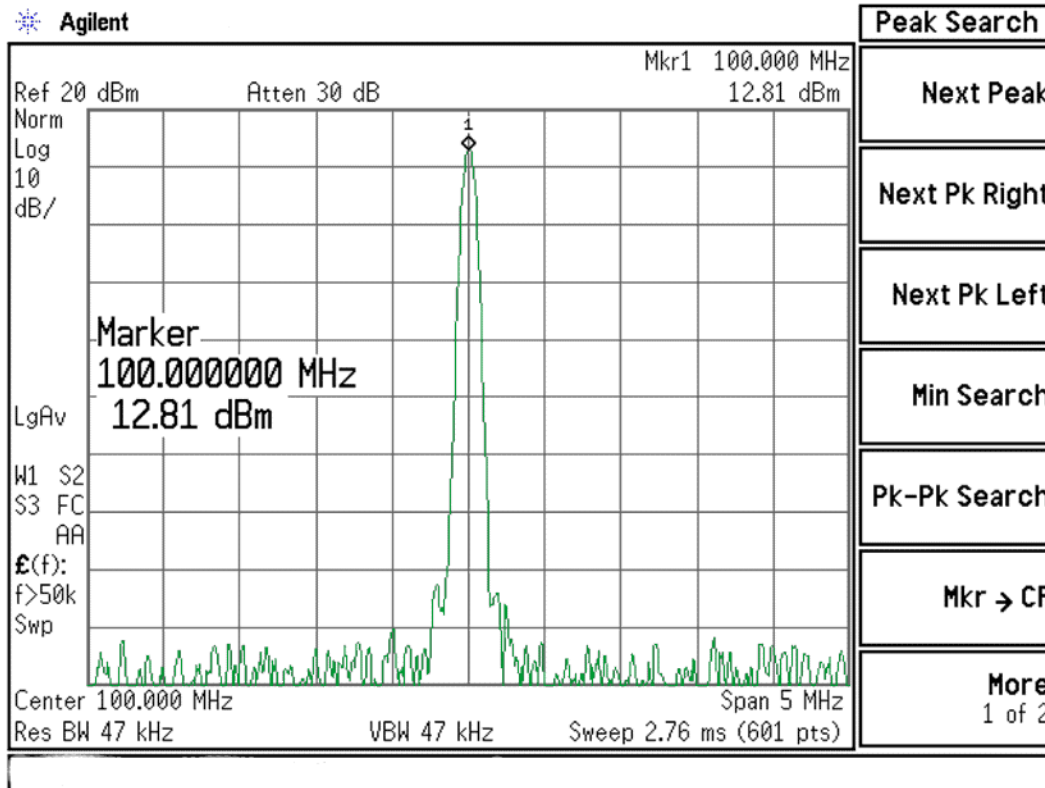


Figure 7-20 100 MHz Ref B Out

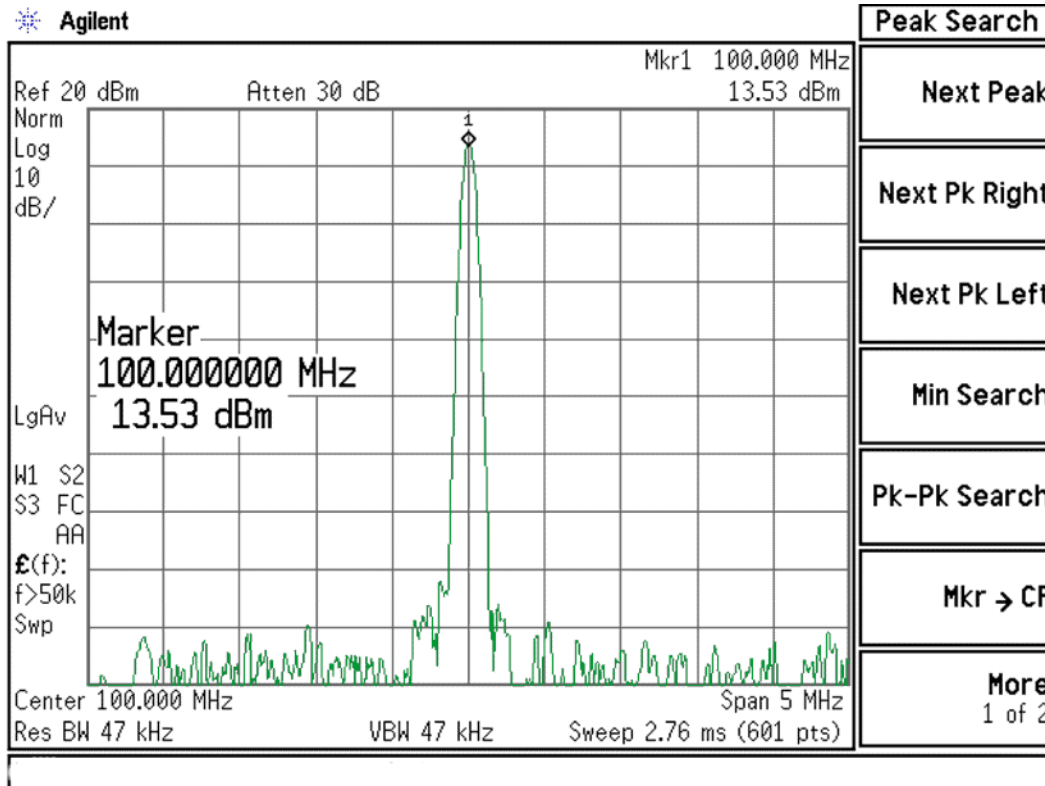
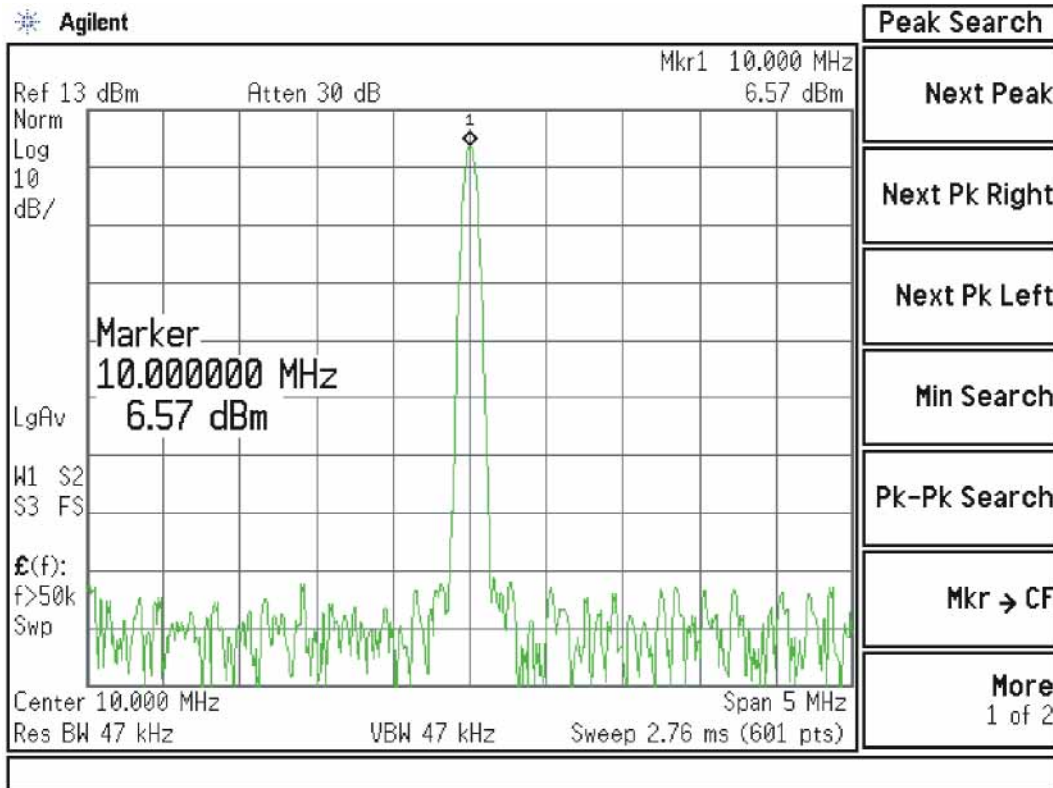


Figure 7-21 10 MHz Output



## Diagnostic LEDs

### Serial Prefix ≥ MY/SG/US5233

There are two sets of diagnostics LEDs on the A16 Reference Assembly. Six LEDs are on the right side of the A16 Reference Main board and five LEDs are on the A16A1 Reference Daughter board. Refer to **Figure 7-9**. **Table 7-4** lists the diagnostic LEDs and what their status indicates.

A blinking red LED typically indicates that an unlevelled condition exists. The number of blinks indicates what circuitry is unlevelled, as indicated in **Table 7-4**.

**Table 7-4** A16 Reference Assembly Diagnostic LEDs

LED Number	Color	Description	Status
A16DS1	Yellow	When Program Code is loading	On=Loading code from EEPROM Off=Ready
A16DS6	Red	100 MHz Unlocked	On=100 MHz VCXO is unlocked 1 Blink = 4.8 GHz calibrator unlevelled 2 Blinks = 50 MHz calibrator unlevelled 3 Blinks = 300 MHz LO_AIF unlevelled Off=Normal (locked)
A16DS7	Green	Is the 100 MHz PLL Unlocked?	On=Normal (locked) Off=Fault (unlocked)
A16DS8	Green	Is the 100 MHz VCXO working?	On=Yes (alive) Off=Fault (not alive)
A16DS9	Green	Is Internal 10 MHz Reference On?	On=Yes (enabled) Off=No (disabled; Ext Ref Mode)
A16DS10	Green	Is the +15V Standby supply working?	On=Yes (+15V Standby supply is on) Off=No
A16A1DS2	Red	When 2.4 or 4.8 GHz frequency is low	On=Fault (output frequency is low) 2 Blinks = 2.4 GHz Ref ALC unlevelled 3 Blinks = 300 MHz Ref ALC unlevelled Off=Normal
A16A1DS3	Red	When 2.4 or 4.8 GHz frequency is high	On=Fault (output frequency is high) 2 Blinks = 4.8 GHz LO ALC unlevelled 3 Blinks = 2.4 GHz LO ALC unlevelled Off=Normal
A16A1DS4	Green	Is the 2.4 GHz reference PLL locked?	On=Normal (locked) Off=Fault (unlocked)
A16A1DS5	Green	Is the 2.4 GHz VCXO working?	On=Yes (alive) Off=Fault (not alive)
A16A1DS6	Yellow	When Program Code is loading	On=Loading code from EEPROM Off=Ready

### Serial Prefix < MY/SG/US5233

The diagnostic LEDs are located near the oven oscillator near the right side of the board. Refer to **Figure 7-10**. **Table 7-5** lists the diagnostic LEDs and what their status indicates.

**Table 7-5** LED Activity

LED Number	Description	Status
DS1	When Program Code is Loading	On=Loading code from EEPROM Off=Ready
DS2	When 4.8 GHz Frequency is Low	On=Fault (Output Frequency too low) Off=Normal
DS3	When 4.8 GHz Frequency is High	On=Fault (Output Frequency too high) Off=Normal
DS4	Is the 4.8 GHz Reference PLL Locked?	On=Normal Off=Fault
DS5	Is the 4.8 GHz Vtune Optimized?	On=Vtune centered in range Off=Vtune off center. No real fault
DS6	Is the 100 MHz PLL Unlocked?	On=Fault Off=Normal
DS7	Is the 100 MHz PLL Locked?	On=Normal Off=Fault
DS8	Is the 100 MHz Out being properly Detected?	On=Normal Off=Fault
DS9	Opt. PFR Out Enabled	On=Internal PFR enabled Off= Internal PFR disabled (Ext. Ref. Mode)

L.O. Synthesizer/Reference Troubleshooting  
A16 Reference Assembly Troubleshooting



## 8 CPU/Disk Drive Troubleshooting

### What You Will Find in This Chapter

**NOTE** Each section first describes how the assembly works, then gives information to help you troubleshoot the assembly. Each description explains the purpose of the assembly, describes the main components, and lists external connections to the assembly.

---

The following sections are found in this chapter:

[A4 CPU Description on page 306](#)

[A5 Disk Drive on page 308](#)

[Troubleshooting software related issues on page 310](#)

[Reloading the X-Series Software on page 311](#)

[Disk Drive Recovery Process on page 312](#)

[Replacing the instrument disk drive on page 313](#)

## A4 CPU Description

If the CPU board is suspect in an instrument failure, a full description of the instrument boot process is described in [Chapter 2, “Boot Up and Initialization Troubleshooting”](#).

### Disk Drive

The A5 Disk Drive assembly is contained within the A4 CPU board assembly and is replaced as an individual assembly. Also, when the A4 CPU board assembly is replaced the existing A5 Disk Drive assembly will be used.

### Front Panel Interface

The instrument USB bus is the electrical interface to the instrument front panel. One of the USB ports on the host controller hub located on the A4 CPU board assembly is routed to the A1A2 Front Panel Interface board for this use. The port is a High Speed USB (2.0) compliant port.

### Graphics Controller

The entire graphics subsystem is contained within a single chip, along with the interface logic to map memory from main system memory for the video RAM. There are two outputs of the graphics controller that are used by the instrument. One provides the LCD video data to drive the internal instrument LCD display and the other supplies the rear panel VGA output.

### Power Supply Control

The power control line from the front panel momentary power switch connects to the A4 CPU board assembly. When the front panel power switch is turned on the A4 CPU board assembly pulls the PS\_ON line to the A6 Power Supply assembly to a TTL low level, which tells the power supply to turn on. Once the +12V D, +5.1V D, and +3.35V D supplies are all on and within specification the A6 Power Supply assembly pulls the PWROK\_H line to a TTL high state, which then causes the A4 CPU board to come out of reset and boot-up.

Outputs from the A4 CPU board assembly also drive the two front panel power state LEDs.

Provisions have also been made to allow the CPU board to remember which power state it was in when a power failure occurs. The instrument will return to the same power state after a power failure.

## Rear Panel Connectivity

The A4 CPU board assembly has direct access to the rear panel of the instrument. The external connections provided on the A4 CPU board assembly include:

- External VGA
- LAN (RJ45) 10/100 based-T Ethernet port
- USB
  - 4 x Type-A ports (USB 2.0 compatible)
  - 1 x Type-B port (USB 2.0 compatible) MXA behaves like a USB device (client)
- GPIB

## System Memory

The type and amount of system RAM in the instrument may vary depending on the age and options installed in an instrument.

Earlier instruments had either 1 or 2 GBytes of DDR DRAM, in either one or two 184-pin DIMM memory modules, while current instruments will have 4 GBytes of DDR SDRAM in two 200-pin SODIMM memory modules.

While the memory controller chips do support a wide range of DDR memory types, only memory fully qualified by Keysight Technologies is supported. Full qualification includes mechanical vibration and shock, thermal and power dissipation and the basic electrical characteristics.

While the A4A1 SRAM Module system memory can be obtained separate from the A4 CPU board assembly for older instruments with the 184-pin DIMM memory modules, the 200-pin SODIMM memory modules are not field replaceable.

All replacement A4 CPU board assemblies come with the appropriate memory modules installed.

## System Processor

The A4 CPU board assembly uses an Intel Pentium-M series processor chip.

## A5 Disk Drive

There are two different types of A5 Disk Drives available. The standard drive is a typical hard disk drive, while the option SSD drive is a solid state (FLASH) drive. There are also different drive capacities and interface types that have been, and are being used, and due to continual changes being made by the drive manufacturers these will continue to change from time to time.

The A5 Disk Drive is physically connected to the CPU assembly. Failures of this disk drive can be either hardware or software related. The first step in trouble shooting is to determine if the failure is software related. If software is found not to be the issue, the disk drive should be replaced.

### **NOTE**

Before replacing the A5 disk drive it is highly recommended that the factory calibration data be backed up to an external drive if at all possible. If this data is not backed up prior to replacing the disk drive all instrument adjustments and performance verification tests will need to be run after the drive is replaced.

For information on how to backup this data see the [“Calibration Data Backup and Restore”](#) section in [Chapter 15](#) of this manual.

---

## Overview

The A5 Disk Drive assembly has been divided up into four different partitions. They are:

Table 8-1

- C.** This partition contains the operating system and software installed by Keysight. This is an open system which means you can install additional software, which should be installed on the C: drive. However, only a limited set of software applications are tested for use with the instrument software. The installation and/or use of other software is not warranted, and could interfere with the operation of the instrument software. If the Agilent Recovery process is ever run, the original version of the C: drive, as shipped from the factory, will be restored. The user will need to reload any other software that was previously installed into the instrument.

Do not save any user data to the C: drive partition, as any data saved in this partition will be lost if the Agilent Recovery process is run.

- D.** This partition is reserved for data storage. The User Accounts that are preconfigured by Keysight and their My Documents folder are mapped to the D: drive. This is for the convenience of backing-up the user data. You should always back-up the data on the D: drive. This allows you to restore the data if the A5 Disk Drive assembly ever needs to be replaced.

Data saved in this partition will not be lost if the Agilent Recovery process is run.

- E.** This partition is reserved for Keysight's use. The primary use of the E: drive is for storing of the instrument Calibration and Alignment data. Do not change or overwrite the files on this drive. This could cause your instrument to not meet specifications, or even to stop functioning correctly. It is also recommended that you back up the contents of this drive. This allows you to restore the data if the A5 Disk Drive assembly ever needs to be replaced, which could otherwise require that all instrument adjustments be performed.

**NOTE:** For information on how to backup this data, see the Calibration Data Backup and Restore section in **Chapter 15** of this manual.

While data saved in this partition will not be lost if the Agilent Recovery process is run, do not use this drive for data storage.

In addition, a hidden recovery partition is located on the drive. This partition contains an image of the C: drive as it was when the instrument was shipped from the factory. To restore the C: drive using the image stored in this recovery partition see the section titled **“Disk Drive Recovery Process” on page 312.**

## Troubleshooting software related issues

The C: drive contains the operating system, either Windows XP or Windows Embedded Standard 7 (WES 7) and the X-Series software. Boot problems can be caused by either a failure of the Windows operating system or the X-Series software. The failure could have occurred due to a failed installation procedure, X-Series software update failure or a virus.

To correct these issues there are two procedures that can be initiated to resolve a software related issue.

- Reload the X-Series software.
- Use the Recovery Process to reinstall the Windows operating system and X-Series software as it was when it left the factory.

## Reloading the X-Series Software

The X-Series software contains all the required components for the signal analyzer application as well as all software options. If the X-Series software has become corrupt the Windows operating system will boot but the X-Series software application will fail to start. In these cases go to **Chapter 17, “Instrument Software.”** for information on how to update the X-Series software. This procedure will not affect the instrument’s calibration or user files.

If this does not resolve the boot issue, or the instrument never boots the Windows operating system proceed to the **“Disk Drive Recovery Process”**.

## Disk Drive Recovery Process

The Agilent Recovery System can be used to repair software errors on the instrument's disk drive, or to restore the original factory configuration of the system software. The Agilent Recovery System is stored in a separate hidden disk drive partition. Repairing errors on the disk drive may result in loss of data or files. Restoring the original factory system software does not restore any of the following items:

- Windows system configurations that were made after the instrument was shipped from the factory. For example, Windows and Service Pack updates, user accounts, and windows configuration settings. After an Agilent Recovery, these configurations will have to be redone by the end user.
- Additional software that was installed after the instrument was shipped from the factory. After an Agilent Recovery, that software will need to be re-installed by the end user.
- Any data or programs saved on the D: or E: drives. This data will be retained on the drive and not altered by the recovery process.
- Any updates that were made to the Keysight measurement application software.

Calibration data is not lost during this process because it resides on the E drive partition.

## Agilent Recovery System

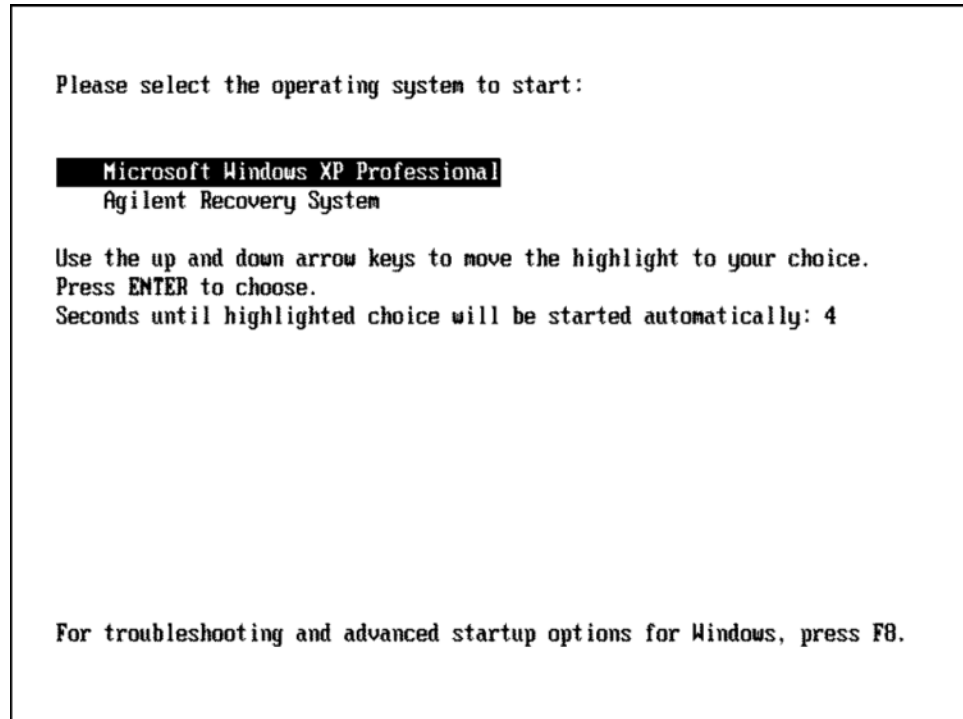
The instrument disk drive recovery system is stored in a separate disk drive partition. It can be used to attempt to repair errors or restore the original factory instrument system on the disk drive.



## Using the Instrument Recovery System

1. Make sure the instrument is turned off.
2. Turn on the instrument.
3. After the “Agilent Technologies” screen is displayed the following screen contents will be displayed for 5 seconds.

Figure 8-1



4. Press the down arrow key to move the highlight to “Agilent Recovery System”, press the **Enter** key.
5. When the Agilent Recovery System has booted, follow the on-screen instructions to recover the image of the C drive.
6. After exiting the Agilent Recovery System, the instrument will reboot a few times.
7. Update the X-Series software to the latest version by downloading it from the following URL:

[www.keysight.com/find/xseries\\_software](http://www.keysight.com/find/xseries_software)

## Replacing the instrument disk drive

If the above two procedures did not resolve the booting issue. The disk drive should be replaced. Please refer to the “**Disk Drive**” replacement section on [page 498](#).

CPU/Disk Drive Troubleshooting  
Disk Drive Recovery Process

## 9 Power Supply/Midplane Troubleshooting

### What You Will Find in This Chapter

The following information is found in this chapter:

**[A6 Power Supply Description on page 316](#)**

**[A6 Power Supply Basic Troubleshooting \(Cover On\) on page 322](#)**

**[A7 Midplane Description on page 324](#)**

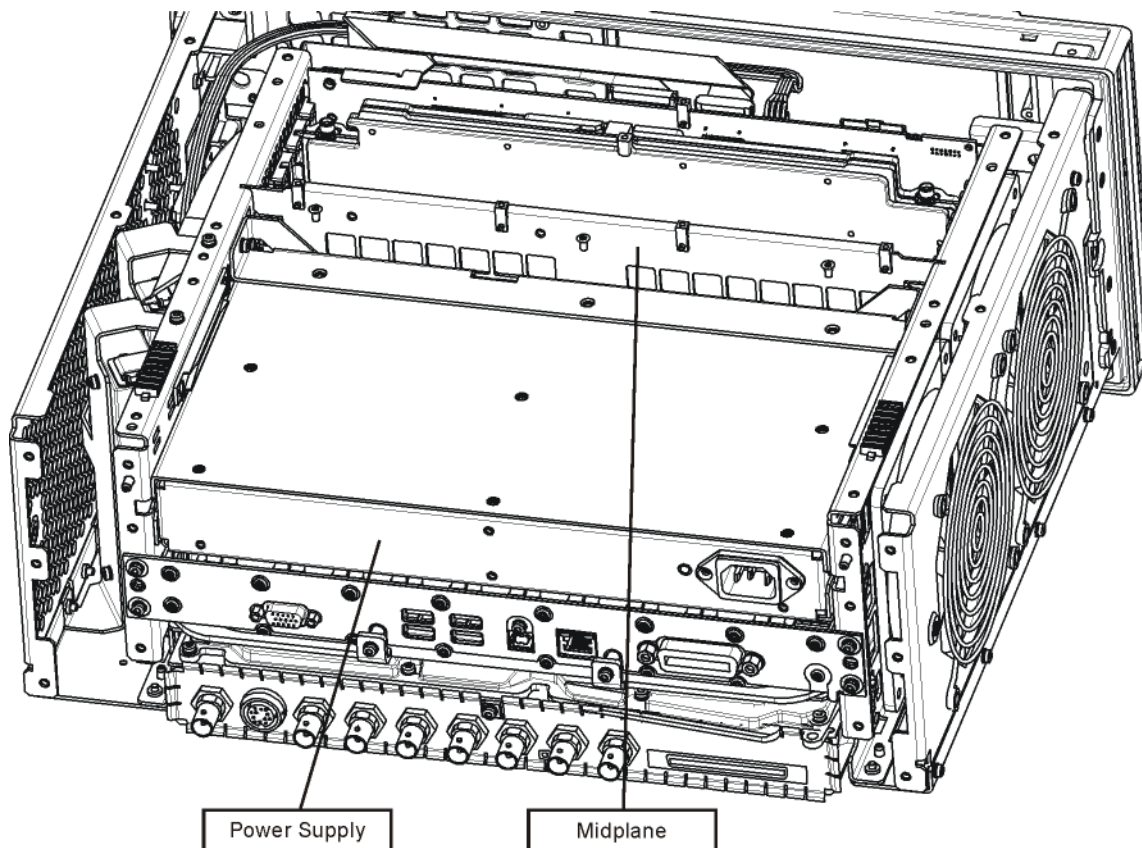
**[A7 Midplane Assembly Troubleshooting on page 327](#)**

## A6 Power Supply Description

### Purpose

The A6 Power Supply assembly provides all the necessary DC voltages for the entire signal analyzer to operate correctly. If any of the power supplies are not within their operating voltages, the analyzer will not function. The power supply outputs provide power to all the printed circuit boards, microcircuit assemblies, front panel display and fans, any of which can cause an over current condition if not operating correctly. The power supply will remain on in an over current state for a minimum of 0.1 second. The power supply will turn off no later than 0.4 seconds after the beginning of the over current state. Any one output over current condition will latch the supply off until the line voltage is removed from the rear panel AC power input connector and then reconnected. The power supply assembly plugs into the A7 Midplane Assembly from the rear of the instrument. (see [Figure 9-1](#).)

Figure 9-1 Power Supply and Midplane



ps\_location

## Power Supply Theory of Operation

The A6 Power Supply assembly is serviced as an assembly only; no component level repair is supported.

The A6 Power Supply assembly provides most all of the necessary DC voltages for the signal analyzer. If any of the power supplies are not within their operating voltages, the instrument will not function properly.

The A6 Power Supply assembly is a switching supply that operates at a frequency of ~120 kHz.

The A6 Power Supply assembly is an auto ranging supply, requiring no user selection of the input voltage. The input AC voltage and frequency requirements for the A6 Power Supply assembly are printed on the rear panel of the instruments as well as on the power supply itself.

While there are no test points or status LEDs accessible for troubleshooting on the A6 Power Supply assembly, there are both test points and status LEDs for all of the different power supply voltages, as well as other power supply status lines, on the A7 Midplane Board assembly. See the [“A7 Midplane Description” on page 324](#) for detailed information on the location of each

### Supply Voltages

The following voltage levels are produced by the A6 Power Supply assembly:

Table 9-1

Voltage Level	Ground Reference	A7 Midplane Connector	Voltage Level	Ground Reference	A7 Midplane Connector
+15V SB	ACOM	J101	+12V D	DCOM	J111
+5.1V SB	DCOM	J111/J112	+5.1V D	DCOM	J109/J110
+32V A	ACOM	J101	+3.35V D	DCOM	J107/J108
+15V A	ACOM	J103/J104	-15V A	ACOM	J105
+9V A	ACOM	J104	-7V A	ACOM	J105
+5.2V A	ACOM	J102	FAN POS	FAN NEG	J101
			FAN NEG	FAN POS	J101

## Control Inputs

There are a number of control inputs for the A6 Power Supply assembly. They are:

### PS\_ON

PS\_ON is a signal that when pulled low tells the A6 Power Supply assembly to turn on all of its outputs. This signal comes from the A4 CPU board assembly and is initiated by pressing the front panel power button.

### DITHER

DITHER is an AC coupled analog signal going to the supply that is used to frequency modulate the power supply switching frequency for the purpose of lowering any power supply related interference.

### OFFn

OFFn is an input that is to be used only as a "Panic Stop". This signal can be used for such functions as an emergency over temperature shut down. This type of shut down is a last resort and does not perform the recommended operating system shut down of the instrument.

### TEMP\_SEN

TEMP\_SEN is an analog input to the fan speed control circuit. The fan runs at a slow speed at room temperature to reduce noise and then will ramp up to full speed as the temperature increases.

## Control/Status Outputs

There are a number of control and status outputs for the A6 Power Supply assembly. They are:

### PWROK\_H

PWROK\_H is used to verify that the +12V D, +5.1V D, and +3.35V D are all on and within specification. A TTL high level on this output brings the CPU out of reset and initiates the instrument boot up process.

### LINE\_TRIG

LINE\_TRIG is a TTL level signal that is synchronous to the AC line input. This signal is typically used in signal analyzers to trigger an instrument sweep synchronous to the AC power line.

### PS\_TEMP

PS\_TEMP is a read out of the internal temperature of the power supply.

### PS\_FAULT

PS\_FAULT will be a TTL low level signal to indicate that the supply is experiencing an over voltage, over current, or over temperature condition.

### **Fuse**

The A6 Power Supply has no user replaceable fuse. While there is a fuse internal to the supply this is not meant for field replacement. If the internal fuse is blown, the power supply has experienced a major failure and should be replaced.

### **Standby Supplies**

The A6 Power Supply assembly has two standby supplies that should always be on if the AC input voltage requirements are met. These are the +15V STBY and the +5.1V STBY supplies. These supplies are used by the instrument to keep certain circuits alive even when the power is turned off.

### **Over Current Protection**

The A6 Power Supply assembly has built in over current protection that will shut down the supply if current draw from the instrument is too great. The power supply will remain on in an over current state for a minimum of 1 second. The power supply shall turn off no later than 5 seconds after beginning the over current state. The power supply shall remain off until the line voltage is removed and then reconnected or the front panel power switch is cycled. Over current shut down does not apply to the standby supplies, the fan voltage, and the +32V A supply.

### **Thermal Protection**

The A6 Power Supply assembly will protect itself by shutting down if it overheats. It will also reset itself with no user interaction after the temperature is reduced by approximately 10 degrees C.

## Power Supply Output Signals

Table 9-2 describes the output signals from the Power Supply assembly.

Table 9-2 Power Supply Output Signals

Signal Name	Description	Maximum Output Current (Amps)	Test Load (Amps)
+32A	32 Volt Analog power supply.	1.8	0.5
+15A	15 Volt Analog power supply	4.25	1.3
+15SB	15 Volt Standby power supply	--	--
+9A	9 Volt Analog power supply	4.0	1.4
+9A_Sense			
+5.2A	5.2 Volt Analog power supply	11.5	3.7
+5.2_Sense			
-7A	-7 Volt Analog power supply	4.5	1.5
-7A_Sense			
-15A	-15 Volt Analog power supply	1.5	0.5
ACOM	Analog Ground. Connected to common ground inside power supply.	--	--
ACOM_Sense	Remote sense for analog ground.	--	--
PS_Faultn	Power supply fault output, active low.	--	--
PS_Temp	Analog temperature output. Control element for fan speed.	--	--
Line_Trig	Line Trigger Output.	--	--
Dither	Dither input from A7 Midplane for switching frequency modulation.	--	--
Temp_Sense	External temperature input for fan speed control.	--	--
Offn	Off input, active low. Used to turn off all non-standby supplies.	--	--
Fan_P	Positive fan power supply.	1.0	0.5
Fan_N	Negative fan power supply.	1.0	0.5
+12D	12 Volt Digital power supply.	8.0	2.6
+5.1D	5.1 Volt Digital power supply.	8.5	2.7
+5.1D_Sense	Remote sense for +5.1 digital supply.	--	--



Table 9-2 Power Supply Output Signals

Signal Name	Description	Maximum Output Current (Amps)	Test Load (Amps)
+5.1SB	5.1 Volt Standby power supply.	0.5	0.2
+3.35D	3.35 Volt Digital power supply.	6.5	2.0
+3.35D_Sense	Remote sense for +3.35 digital supply.	--	--
DCOM	Digital ground. Connected to the common ground point inside the power supply.	--	--
DCOM_Sense	Remote sense for DCOM.	--	--
PWR_OK	Power OK Output.	--	--
PS_ONn	Power supply turn on input, active low.	--	--
ChassisCOM	Power supply outer case. Connected to common ground point inside the power supply.	--	--

## A6 Power Supply Basic Troubleshooting (Cover On)

**NOTE** There are no user replaceable fuses on the power supply. If the internal fuse is blown, the power supply has experienced a major failure and should be replaced. If you determine that the power supply is the failed assembly, replace the power supply. If the power supply is suspect, perform the following quick checks before removing the instrument cover.

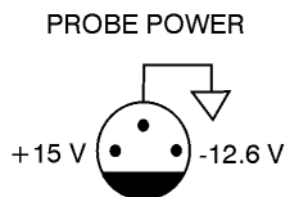
---

1. Ensure the instrument is plugged into a known good AC power source and the yellow standby LED near the power on switch is illuminated. A lit yellow LED indicates the +5.1 SB VDC power supply voltage is providing enough voltage to light the LED.
2. Power on the instrument and verify that the green LED on the front panel is lit. A lit LED indicates the power supply has received an “ON” command from the A4, CPU assembly and that the +5.2A VDC supply is on.
3. Verify both fans are operating on the side panel of the instrument. The fans can be heard once the analyzer is powered up. If the fans are operating, the fan power supply is functioning.
4. The front panel probe power connector can be used to check the +15 VDC (+/- 7%) and -12.5 VDC (+/-10%) supplies. The -12.5 VDC is produced by post regulating the -15 VDC supply. A voltmeter can be used to verify these supplies. Refer to [Figure 9-2](#) for a diagram of the probe power connector.

**CAUTION** Exercise great care when measuring voltages on the Probe Power connector. Accidentally shorting the +15V or -12.6V supply to ground can cause damage to the A1A2 or A1A5 assemblies.

---

Figure 9-2 Probe Power Connector



sa869a

If these initial checks are functioning properly and yet the signal analyzer will not boot up properly, or the display is not turning on, refer to [Chapter 2, “Boot Up and Initialization Troubleshooting”](#) in this service manual.

---

It is possible that some portion of the initial troubleshooting check may fail. **Chapter 2** should also be referenced if this is the case. As an example, the A15 Front End Control Assembly may be pulling down the +15 volt supply that is used for the probe power on the front panel. **Chapter 2** describes the entire instrument boot process, from initial power on to a successful signal analyzer sweep. If any portion of the boot process fails, **Chapter 2** describes a step-by-step troubleshooting procedure to help isolate the root cause of the failure.

## A7 Midplane Description

### Purpose

The Midplane links the following major assemblies:

- A4 CPU Assembly
- A6 Power Supply Assembly
- A8 Motherboard
- A16 Reference Assembly

Refer to **Figure 9-3**. The Midplane Assembly **(7)** plugs into the Motherboard. The CPU, Power Supply, and Reference Assemblies plug directly into the Midplane board from the rear of the instrument. The Analog and Digital I.F. Assemblies plug into the analyzer from the rear of the instrument into the Motherboard itself.

### Instrument Power Supply LEDs and Test Points

While the A6 Power Supply assembly has no user accessible LEDs or test points the A7 Midplane board assembly does provide these for all of the different instrument power supplies as well as many of the power supply status lines. A complete list of these can be found in **Table 9-4** and the location of each can be seen in **Figure 9-4**.

### Additional Power Supply Regulation

There are two analog power supply regulators on the A7 Midplane board assembly. They are the +3.3VA and -5.2VA supplies. The +3.3VA supply is regulated down from the instrument +5.1VA supply while the -5.2VA supply is regulated down from the -7VA instrument supply. Both of these supply voltages have test points and LEDs on the A7 Midplane board assembly as seen in **Figure 9-4**.

### Instrument Secure Storage

This is Non-volatile storage of instrument model number, serial number, and software license keys. While the license keys are also contained on the C: drive of the instrument, the model and serial numbers are only saved in this secure memory. There is no way for the user to access this memory in any way. This is reserved for the factory and field software when needed for instrument initialization, as well as the instrument software when installing an option license key. If for some reason any of these cannot be remembered by the instrument there could be a problem with this memory and the A7 Midplane board assembly would need to be replaced.

### **Power Supply Dithering**

A triangle wave of approximately 100 Hz is generated and goes directly to the A6 Power Supply assembly. This is used to frequency modulate the power supply switching frequency for the purpose of lowering any power supply related interference. If for some reason the level of the power supply related interference is higher than normal this circuitry, or the A6 Power Supply assembly, could be suspect.

### **Miscellaneous Circuitry**

Other circuitry on the A7 Midplane include a circuit to phase lock the CPU clock to the analyzer's 10 MHz reference and a Complex Programmable Logic Device (CPLD) used as an Instrument Local Bus (ILB) buffer to A16 Reference Assembly connector at J21.

Figure 9-3 Midplane

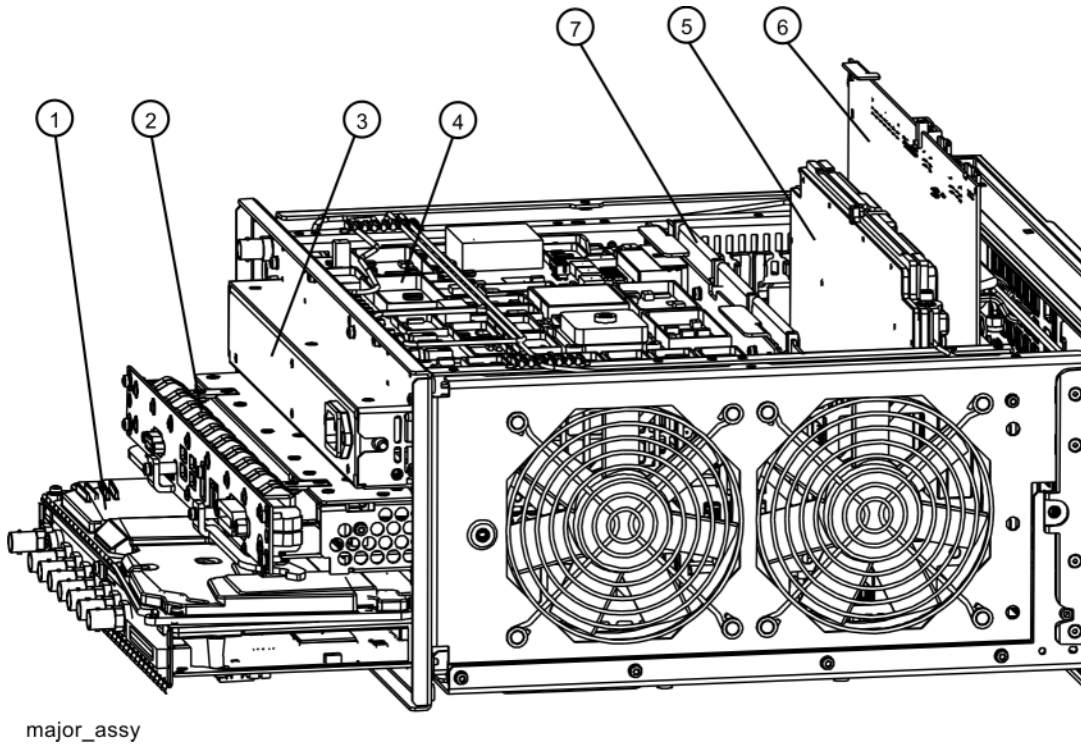


Table 9-3

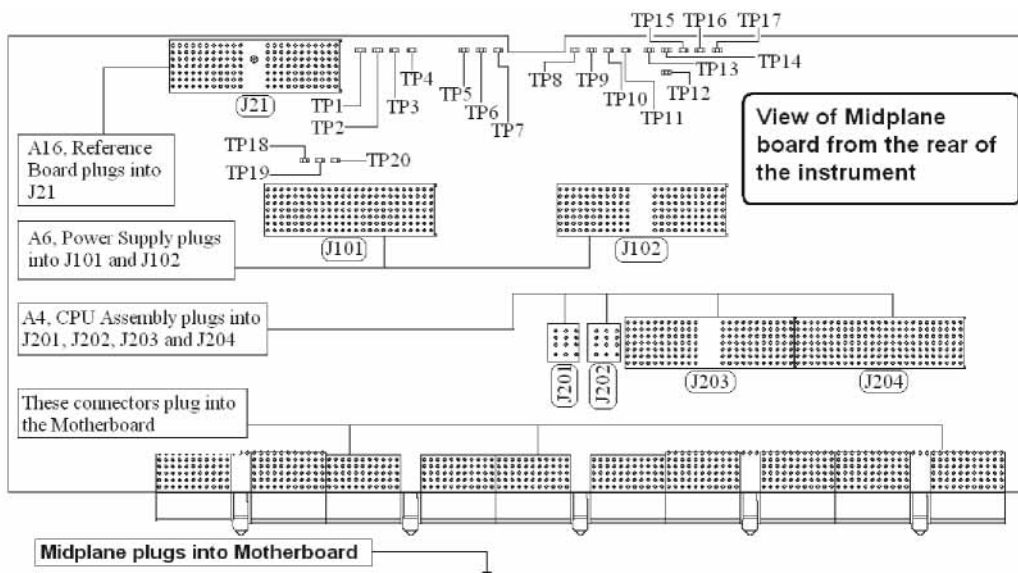
Item	Description
1	A2 Analog I.F. Assembly A3 Digital I.F. Assembly
2	A4 CPU Replacement Kit (w/o disk drive)
3	A6 Power Supply
4	A16 Reference Assembly
5	A14 L.O. Synthesizer Assembly
6	A15 Front End Control Assembly
7	A7 Midplane Assembly

**NOTE** The L.O. Synthesizer, Front End Control Assembly, Analog IF, and Digital IF plug into the Motherboard. All other assemblies mentioned plug into the Midplane from the rear of the instrument.

## A7 Midplane Assembly Troubleshooting

If there is an analyzer function such as a boot up issue where the power supplies are suspect, view the power supply LED's on the Midplane Assembly by removing the instrument outer cover. See [Figure 9-4](#).

Figure 9-4 Midplane Assembly



As shown above, the Midplane Assembly has test points for each power supply that can be used as measurement points. These DC voltages can be verified with a voltmeter. Continuity measurements can also be performed on each power supply if a shorted condition is suspect. Refer to the table below for measurement details.

**NOTE** Voltage readings are referenced to ACOM (TP4). All ohmmeter measurements were taken from the power supply test point to ACOM. Due to capacitive effects, wait for the ohmmeter readings to stabilize.

Table 9-4 A7 Midplane Board Test Points

Power Supply	Test Point	Description	Expected Voltmeter Reading (VDC) Power ON	Expected Ohmmeter Reading (K $\Omega$ ) Power OFF
+32A	TP3	32 Volt Analog supply	+32 $\pm$ 2.0	1.3 k $\Omega$
+15A	TP6	15 Volt Analog supply	+15 $\pm$ 1.0	260 $\Omega$
+15SB	TP2	15 Volt Standby supply	+15 $\pm$ 1.0	264 $\Omega$
+12D	TP16	12 Volt Digital supply	+12 $\pm$ 1.0	264 $\Omega$
+9A	TP7	9 Volt Analog supply	+9 $\pm$ 1.0	120 $\Omega$
+5.2A	TP5	5.2 Volt Analog supply	+5.2 $\pm$ 0.75	3.6 k $\Omega$
+5.1D	TP15	5.1 Volt Digital supply	+5.1 $\pm$ 0.75	40 $\Omega$
+5.1SB	TP17	5.1 Volt Standby	+5.1 $\pm$ 0.75	228 $\Omega$
+3.35D	TP13	3.35 Volt Digital supply	+3.35 $\pm$ 0.75	47 $\Omega$
+3.3A	TP10	3.3 Volt Analog supply	+3.3 $\pm$ 0.75	36 $\Omega$
-5.2A	TP11	-5.2 Volt Analog supply	-5.2 $\pm$ 0.75	1.9 $\Omega$
-7A	TP8	-7 Volt Analog supply	-7 $\pm$ 1.0	445 $\Omega$
-15A	TP9	-15 Volt Analog supply	-15 $\pm$ 1.0	390 $\Omega$
n/a	TP1	Fan Positive supply	8.5 to 13.5 VDC ~8.8 VDC @ 25C	490 $\Omega$
n/a	TP4	Analog Common	n/a	n/a
n/a	TP14	Digital Common	n/a	n/a
n/a	TP12	Power OK	+3.9 $\pm$ 0.75	9.2 k $\Omega$



## 10 Front Panel/Motherboard Troubleshooting

### What You Will Find in This Chapter

The following information is found in this chapter:

**[A8 Motherboard Description on page 330](#)**

**[A1 Front Panel Assembly on page 332](#)**

**[Option BBA Description on page 333](#)**

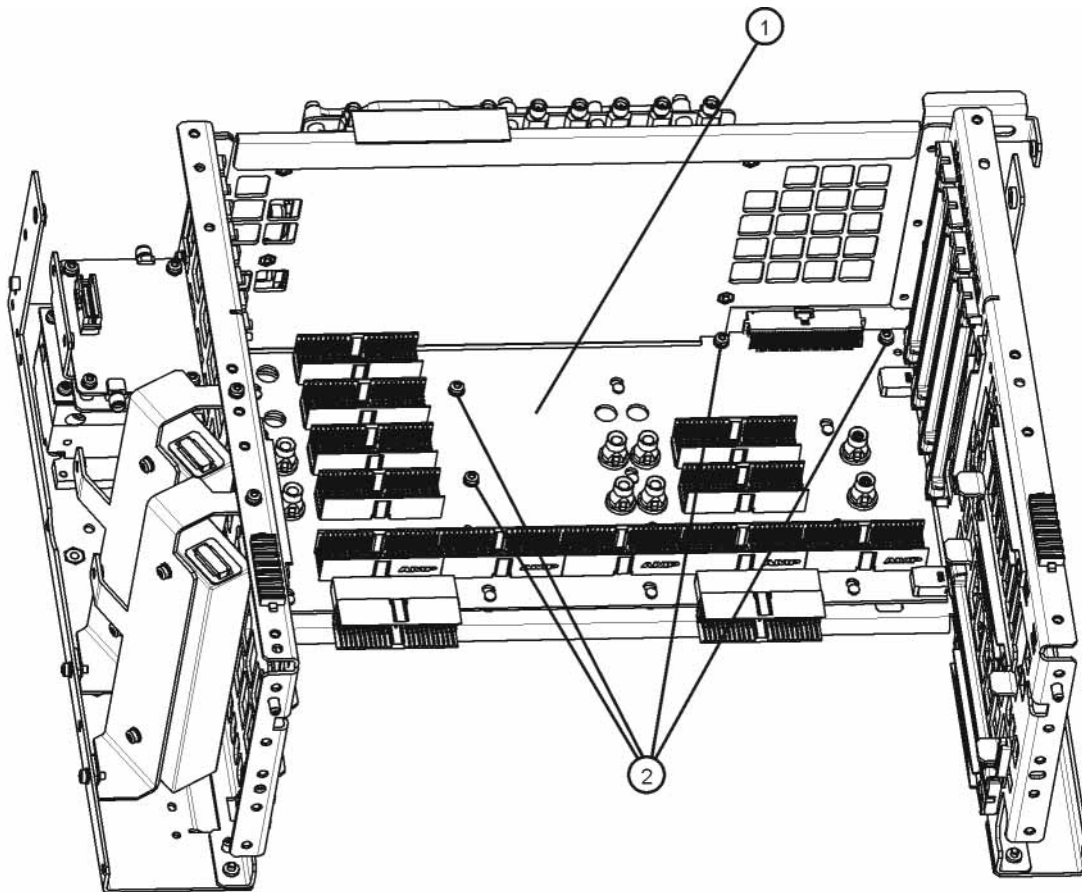
## A8 Motherboard Description

### Purpose

The Motherboard is an electrical link between many of the electrical assemblies in the instrument. The main functions of this PC board include:

- Distribute power
- Control and common signals between all the measurement PC boards including the A7 Midplane and the Front Panel Assembly
- Circuitry for fan speed control
- 10 MHz Reference distribution

Figure 10-1 Motherboard



motherboard\_replace

The Motherboard is a horizontally mounted, located near the bottom of the analyzer. The Motherboard has the following connector types:

Front Panel/Motherboard Troubleshooting  
A8 Motherboard Description

- (6) Analog Card Cage Connectors (J1, J11, J31, J41, J51, J61)
- (4) Digital Card Cage Signals and voltages using PCI connectors (J4, J12, J32, J42)
- (1) Analog Power (J2)
- (1) Mixed Power (J3)
- (2) Front Panel Connectors (J5 and J9)
- (2) Fan Connector (J6 and J7)

Figure 10-2 Motherboard Connectors

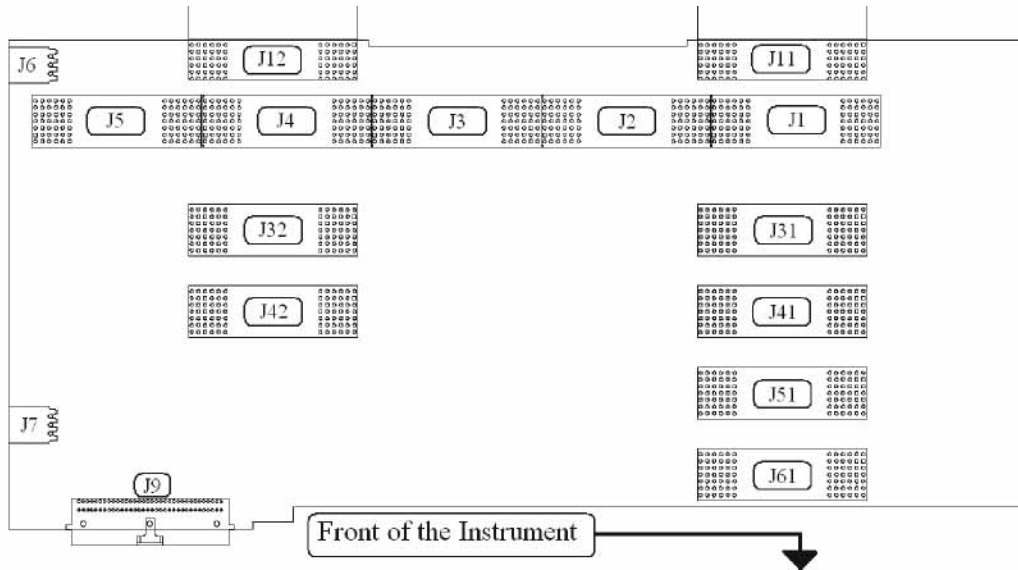


Table 10-1

Motherboard Connector	What Plugs In?	Motherboard Connector	What Plugs In?
J1	A7, Midplane	J11	A3, Digital I.F, analog signals
J2	A7, Midplane	J12	A3, Digital I.F, analog signals
J3	A7, Midplane	J31	Option Slot
J4	A7, Midplane	J32	Option Slot
J5	A7, Midplane	J41	Option Slot
J6	B2, Fan #2	J42	Option Slot
J7	B1, Fan #1	J51	A14, L.O. Synthesizer
J9	Front Panel	J61	A15, Front End Control

A8 Motherboard Troubleshooting

There are no troubleshooting procedures for this assembly. If the Motherboard is suspect, it must be replaced.

## A1 Front Panel Assembly

The major components of the A1 Front Frame Assembly are the A1A2 Front Panel Interface Board, A1A3 LCD, A1A4 LCD Inverter Board/DC-DC Converter, and the A1A5 Front Panel USB Interface Board, all of which are serviceable as individual components.

The A1 assembly is used to display the measurement results, accept user input via the keyboard, and connect USB peripheral devices.

### A1A2 Front Panel Interface Board

The A1A2 Front Panel Interface board is serviced as an assembly only; no component level repair is supported.

The Front Panel Interface Board contains LCD control, Inverter drive, audio amplifiers, internal speaker, a 4 port USB hub, and a USB keyboard microcontroller.

The two different front panel rubber keypads attach to the back side of the board, which has the keyboard contacts printed on the reverse side.

The 4 ports from the USB hub contained on this board go to the 2 front panel USB connectors, the keyboard microcontroller, and the fourth port is unused.

### A1A3 LCD

The LCD used is an 8.4 inch XGA TFT display, which has a resolution of 1024 x 768. It has two backlights that are not individually replaceable.

### A1A4 LCD Inverter Board/DC-DC Converter

The Inverter Board provides the high voltage required by the LCD backlights used on older MXA's. Newer MXA's use a DC-DC Converter to power the LED backlights.

### A1A5 Front Panel USB Interface Board

The Front Panel USB Interface Board provides the front panel USB connections.

## Option BBA Description

The Analog Baseband I/Q inputs is a hardware option for the N9020A, Signal Analyzer. The option can be ordered at the time of sale as N9020A-BBA or as a post sale upgrade as N9020AK-BBA. This option requires a license key to be fully operational.

The BBIQ option consists of 4 main components:

- LED board
- BBIQ Interface board
- BBIQ Main board
- Low noise ribbon cable that connects the BBIQ Interface board to the BBIQ Main board

### A17 LED Board

- Contains two edge connectors; J2 and J1 that plug into J20 and P100 edge connectors on the BBIQ Interface board
- Five visible LEDs for user information
- Probe interface contact signals for all four channels I, I, Q, and Q

### A18 BBIQ Interface Board

- Allows switching between Single Ended (SE) and Differential (Balanced) for the two input channels.
- Accommodates 1 M  $\Omega$  and 50  $\Omega$  input paths
- Converts all signals to a differential format with a 2.5V common-mode voltage to route to the BBIQ Main board over a 60-pin micro coaxial connector at J1
- Power and control for the BBIQ Interface board are provided from the BBIQ Main board via a ribbon cable, though some of the power supplies are locally regulated on the BBIQ Interface board to minimize spurious responses
- A square wave calibration signal is provided to the user via a BNC Cal Out connector on the BBIQ Interface board. This signal originates on the BBIQ Main board and is buffered and attenuated on the BBIQ Interface board
- Passes signals for the LED board and Infinimax probe ID and power from the 60-pin connector from the BBIQ Main board to a pair of edge connectors that interface to the LED board. ESD protection is provided on the BBIQ Interface board
- EEPROM is used to identify the board and relay drivers to accommodate the input path switching. Some of the relay drivers that require fast switching (for over voltage protection) are on the BBIQ Main board

- Shields are on the board to minimize spurious responses

## A19 BBIQ Main Board

- Provides probe power to the BBIQ Interface board
- Power Supply filtering and regulation
- Contains FPGA (field programmable gate arrays)
- Provides LED control to the LED board
- Receives I, I, Q, and Q data from BBIQ Interface board
- Controls (9) relays on the BBIQ Interface board
- Provides probe identification for system use
- Overload detection
- On board relay control for various gain stages
- Variable gain stages
- Provides square wave calibrator output signal to BBIQ Interface board
- Dither
- 10 MHz input from the Reference board
- Onboard 16 bit 100Ms/S ADC
- Triggering Circuits

## 11 Block Diagrams

### What You Will Find in This Chapter

The following sections are found in this chapter:

- [RF Lowband Path Block Diagram on page 337](#)
- [RF Highband Path #1 Block Diagram on page 338](#)
- [RF Highband Path #2 Block Diagram on page 339](#)
- [25 MHz Bandwidth I.F. System Block Diagram on page 342](#)
- [40 MHz Bandwidth I.F. System Block Diagram on page 343](#)
- [≥ 85 MHz Bandwidth IF System Block Diagram on page 344](#)
- [Reference and Synthesizer Block Diagram \(Serial Prefix < MY/SG/US5233 without Option B85, B1A, or B1X\) on page 340](#)
- [Reference and Synthesizer Block Diagram \(Serial Prefix ≥ MY/SG/US5233 and all with Option B85, B1A, or B1X\) on page 341](#)
- [MXA Computer Block Diagram on page 345](#)
- [BBIQ System Block Diagram on page 346](#)

# Block Diagrams

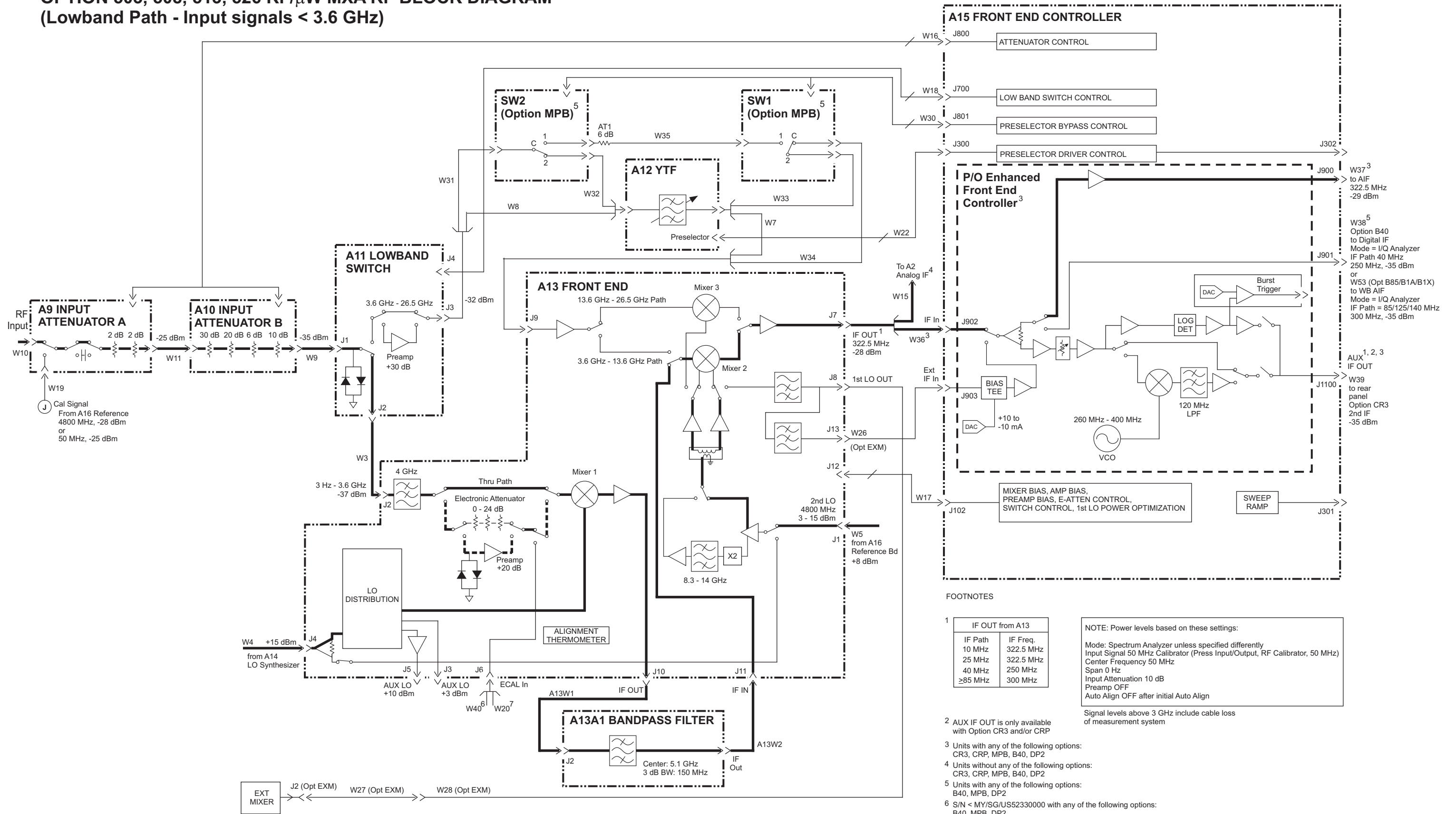
## Graphic Symbols Used On Block Diagrams

	Bus Line		Op Amplifier		Band Pass Filter
	Indicates a plug-in connection (F) to (M)		Summer		High Pass Filter
	Connection symbol indicating plug (movable)		Phase Frequency Detector		Low Pass Filter
	Connection symbol indicating jack (movable)		Mixer		Band Reject Filter
	Heavy line indicates path and direction of main signal		Oscillator or Generator		Common Return
	Color code for cable		Capacitor		Numbered Test Point. Measurement aid provided.
	Variable Gain Amplifier		Resistor		Lettered Test Point. No Measurement aid provided.
	Amplifier Buffer		Variable Resistor		Slide, Toggle, or Rocker, Switch
	Inverter Buffer		Switch Open		Grounded Coaxial Shielding
	Limiter		Diode		Analog Digital Convertor
	Variable Integrator		Digital Analog Convertor		Directional Coupler

sa83a



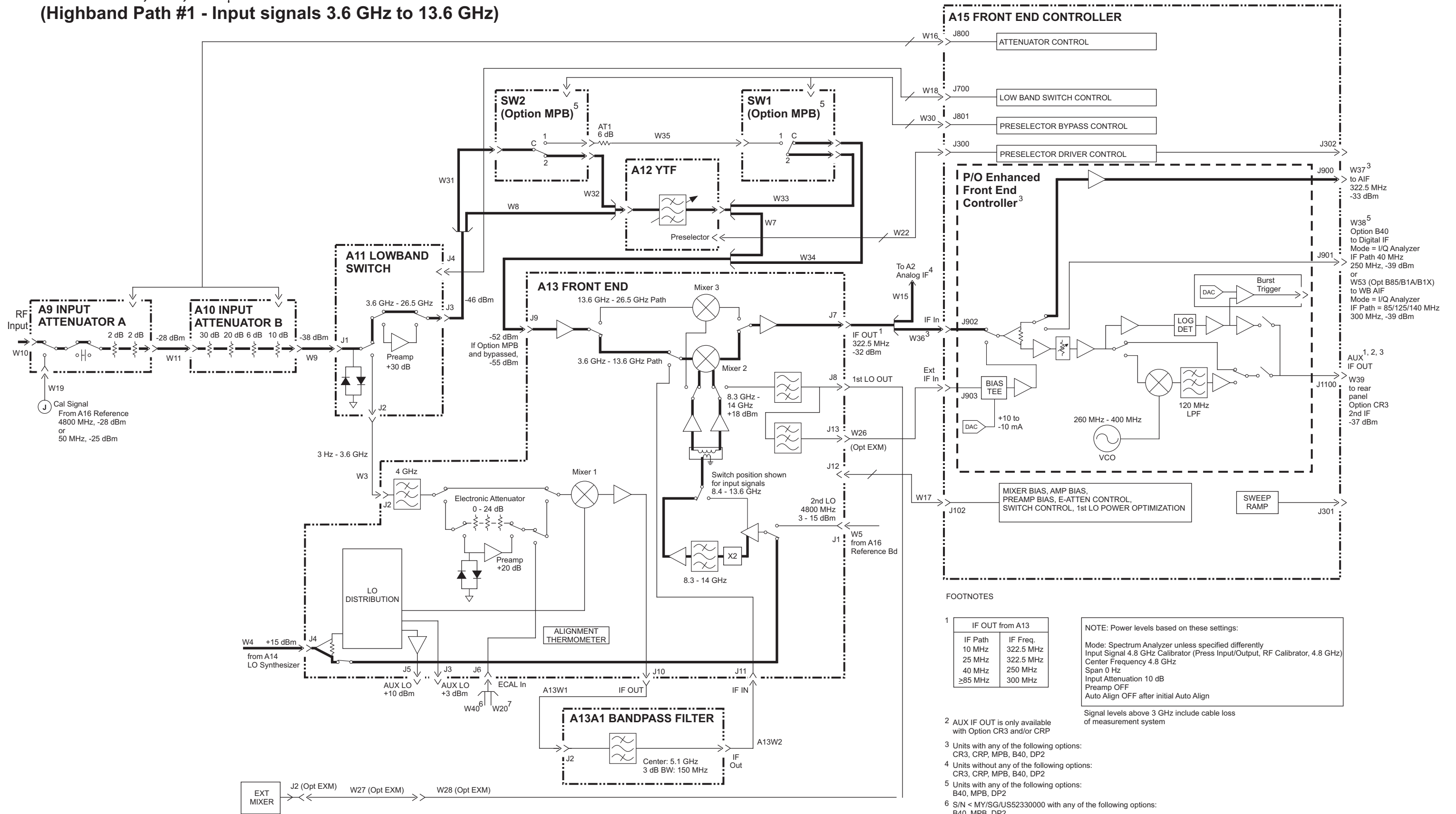
**OPTION 503, 508, 513, 526 RF/ $\mu$ W MXA RF BLOCK DIAGRAM**  
**(Lowband Path - Input signals < 3.6 GHz)**



**FOOTNOTES**

- | 1 IF OUT from A13 |           |
|-------------------|-----------|
| IF Path           | IF Freq.  |
| 10 MHz            | 322.5 MHz |
| 25 MHz            | 322.5 MHz |
| 40 MHz            | 250 MHz   |
| ≥85 MHz           | 300 MHz   |
- NOTE: Power levels based on these settings:  
 Mode: Spectrum Analyzer unless specified differently  
 Input Signal 50 MHz Calibrator (Press Input/Output, RF Calibrator, 50 MHz)  
 Center Frequency 50 MHz  
 Span 0 Hz  
 Input Attenuation 10 dB  
 Preamp OFF  
 Auto Align OFF after initial Auto Align  
 Signal levels above 3 GHz include cable loss of measurement system
- 2 AUX IF OUT is only available with Option CR3 and/or CRP
- 3 Units with any of the following options: CR3, CRP, MPB, B40, DP2
- 4 Units without any of the following options: CR3, CRP, MPB, B40, DP2
- 5 Units with any of the following options: B40, MPB, DP2
- 6 S/N < MY/SG/US52330000 with any of the following options: B40, MPB, DP2
- 7 S/N < MY/SG/US52330000 without any of the following options: B40, MPB, DP2 or S/N ≥ MY/SG/US52330000

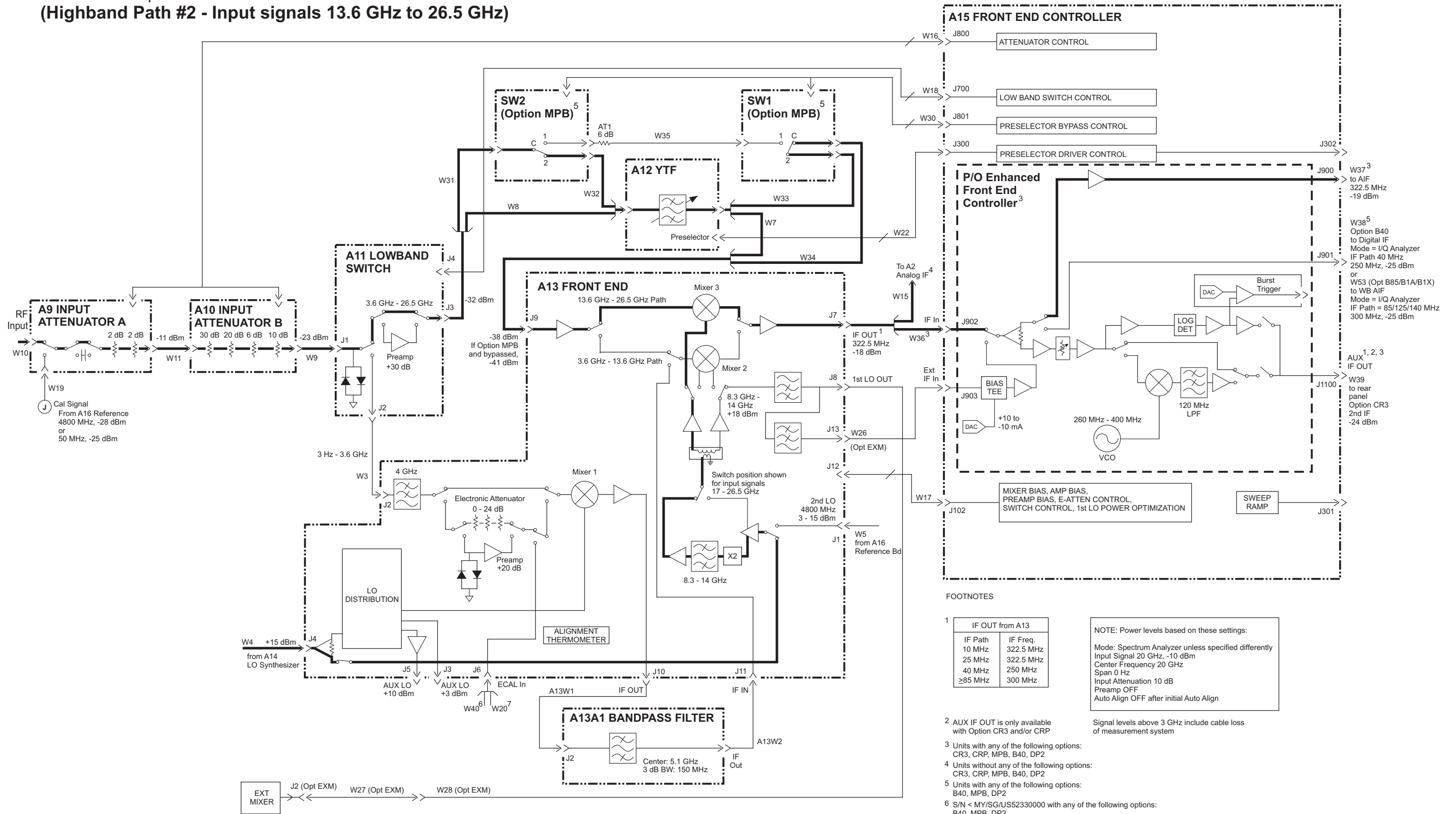
**OPTION 508, 513, 526  $\mu$ W MXA RF BLOCK DIAGRAM**  
**(Highband Path #1 - Input signals 3.6 GHz to 13.6 GHz)**



**FOOTNOTES**

- | 1 IF OUT from A13 |           |
|-------------------|-----------|
| IF Path           | IF Freq.  |
| 10 MHz            | 322.5 MHz |
| 25 MHz            | 322.5 MHz |
| 40 MHz            | 250 MHz   |
| ≥85 MHz           | 300 MHz   |
- NOTE: Power levels based on these settings:  
 Mode: Spectrum Analyzer unless specified differently  
 Input Signal 4.8 GHz Calibrator (Press Input/Output, RF Calibrator, 4.8 GHz)  
 Center Frequency 4.8 GHz  
 Span 0 Hz  
 Input Attenuation 10 dB  
 Preamp OFF  
 Auto Align OFF after initial Auto Align  
 Signal levels above 3 GHz include cable loss of measurement system
- 2 AUX IF OUT is only available with Option CR3 and/or CRP
- 3 Units with any of the following options: CR3, CRP, MPB, B40, DP2
- 4 Units without any of the following options: CR3, CRP, MPB, B40, DP2
- 5 Units with any of the following options: B40, MPB, DP2
- 6 S/N < MY/SG/US52330000 with any of the following options: B40, MPB, DP2
- 7 S/N < MY/SG/US52330000 without any of the following options: B40, MPB, DP2 or S/N ≥ MY/SG/US52330000

# OPTION 526 $\mu$ W MXA RF BLOCK DIAGRAM (Highband Path #2 - Input signals 13.6 GHz to 26.5 GHz)



### FOOTNOTES

1

IF OUT from A13	
IF Path	IF Freq.
10 MHz	322.5 MHz
25 MHz	322.5 MHz
40 MHz	250 MHz
$\geq 85$ MHz	300 MHz

NOTE: Power levels based on these settings:  
 Mode: Spectrum Analyzer unless specified differently  
 Input Signal 20 GHz, -10 dBm  
 Center Frequency 20 GHz  
 Span 0 Hz  
 Input Attenuation 10 dB  
 Preamp OFF  
 Auto Align OFF after initial Auto Align

2 AUX IF OUT is only available with Option CR3 and/or CRP

Signal levels above 3 GHz include cable loss of measurement system

3 Units with any of the following options: CR3, CRP, MPB, B40, DP2

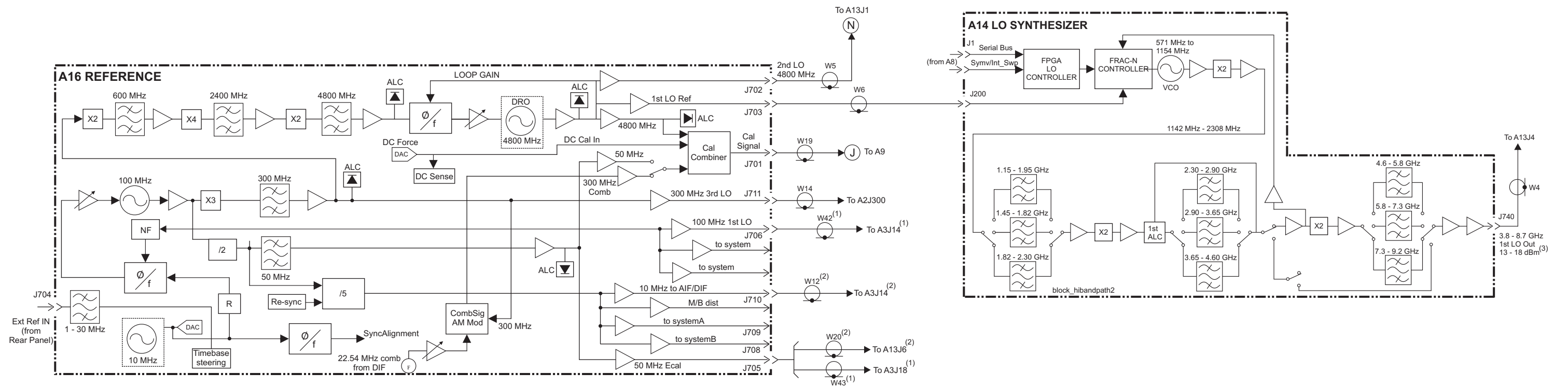
4 Units without any of the following options: CR3, CRP, MPB, B40, DP2

5 Units with any of the following options: B40, MPB, DP2

6 S/N < MY/SG/US52330000 with any of the following options: B40, MPB, DP2

7 S/N < MY/SG/US52330000 without any of the following options: B40, MPB, DP2 or S/N  $\geq$  MY/SG/US52330000

**REFERENCE and SYNTHESIZER BLOCK DIAGRAM**  
 (Serial Prefix < MY/SG/US5233 without Option B85, B1A, or B1X)



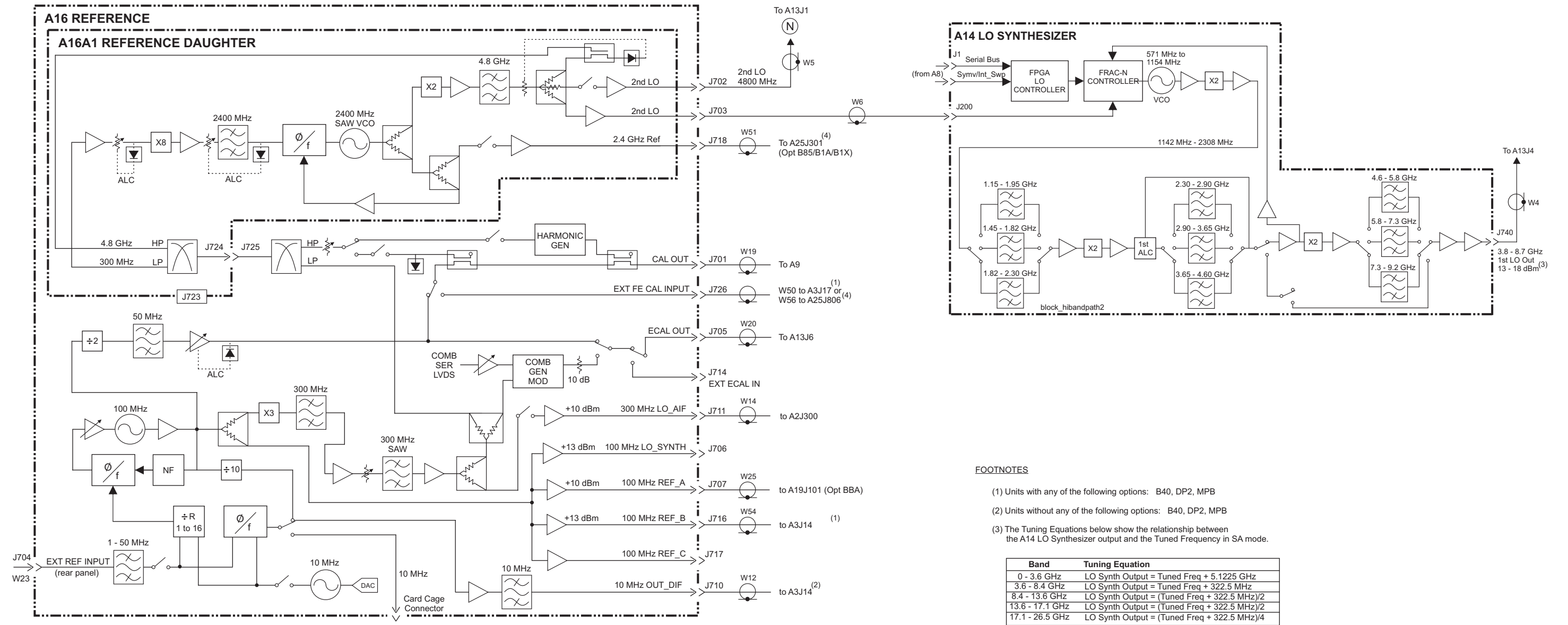
**FOOTNOTES**

- (1) Units with any of the following options: B40, DP2, MPB
- (2) Units without any of the following options: B40, DP2, MPB
- (3) The Tuning Equations below show the relationship between the A14 LO Synthesizer output and the Tuned Frequency in SA mode.

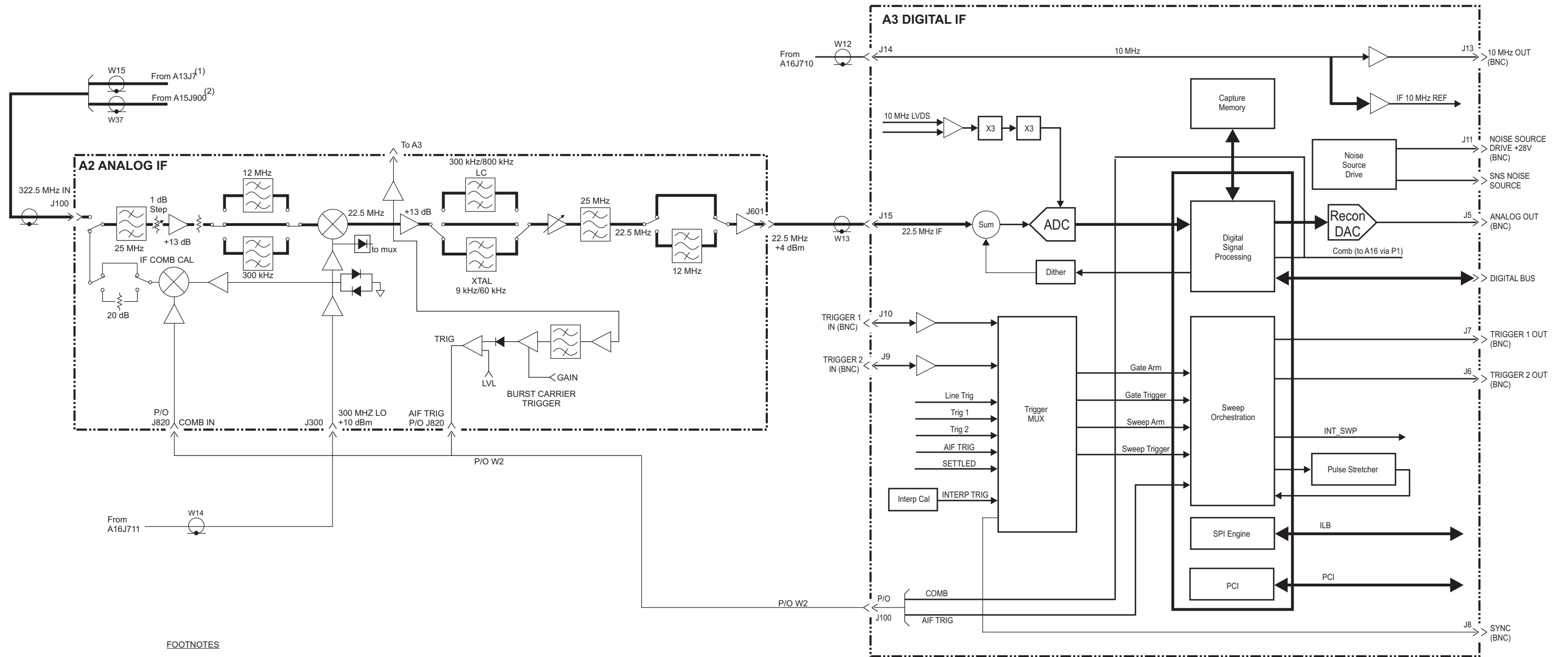
Band	Tuning Equation
0 - 3.6 GHz	LO Synth Output = Tuned Freq + 5.1225 GHz
3.6 - 8.4 GHz	LO Synth Output = Tuned Freq + 322.5 MHz
8.4 - 13.6 GHz	LO Synth Output = (Tuned Freq + 322.5 MHz)/2
13.6 - 17.1 GHz	LO Synth Output = (Tuned Freq + 322.5 MHz)/2
17.1 - 26.5 GHz	LO Synth Output = (Tuned Freq + 322.5 MHz)/4

**REFERENCE and SYNTHESIZER**  
**BLOCK DIAGRAM**

**REFERENCE and SYNTHESIZER BLOCK DIAGRAM**  
 (Serial Prefix  $\geq$  MY/SG/US5233 and all with Option B85, B1A, or B1X)



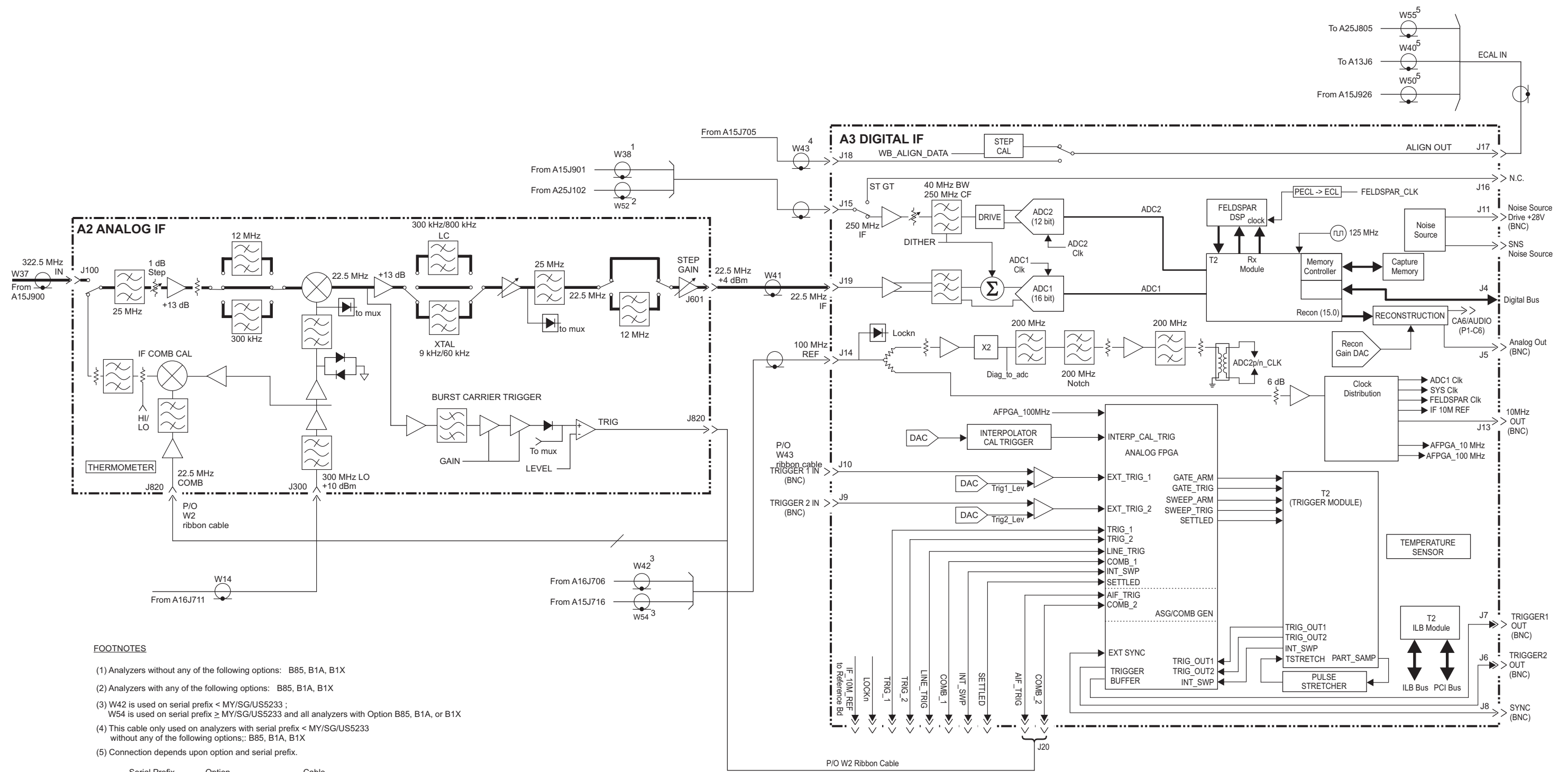
# 25 MHz BW IF SYSTEM BLOCK DIAGRAM



## FOOTNOTES

- (1) Units without any of the following options: CR3, CRP
- (2) Units with any of the following options: CR3, CRP

# 40 MHz BW IF SYSTEM BLOCK DIAGRAM

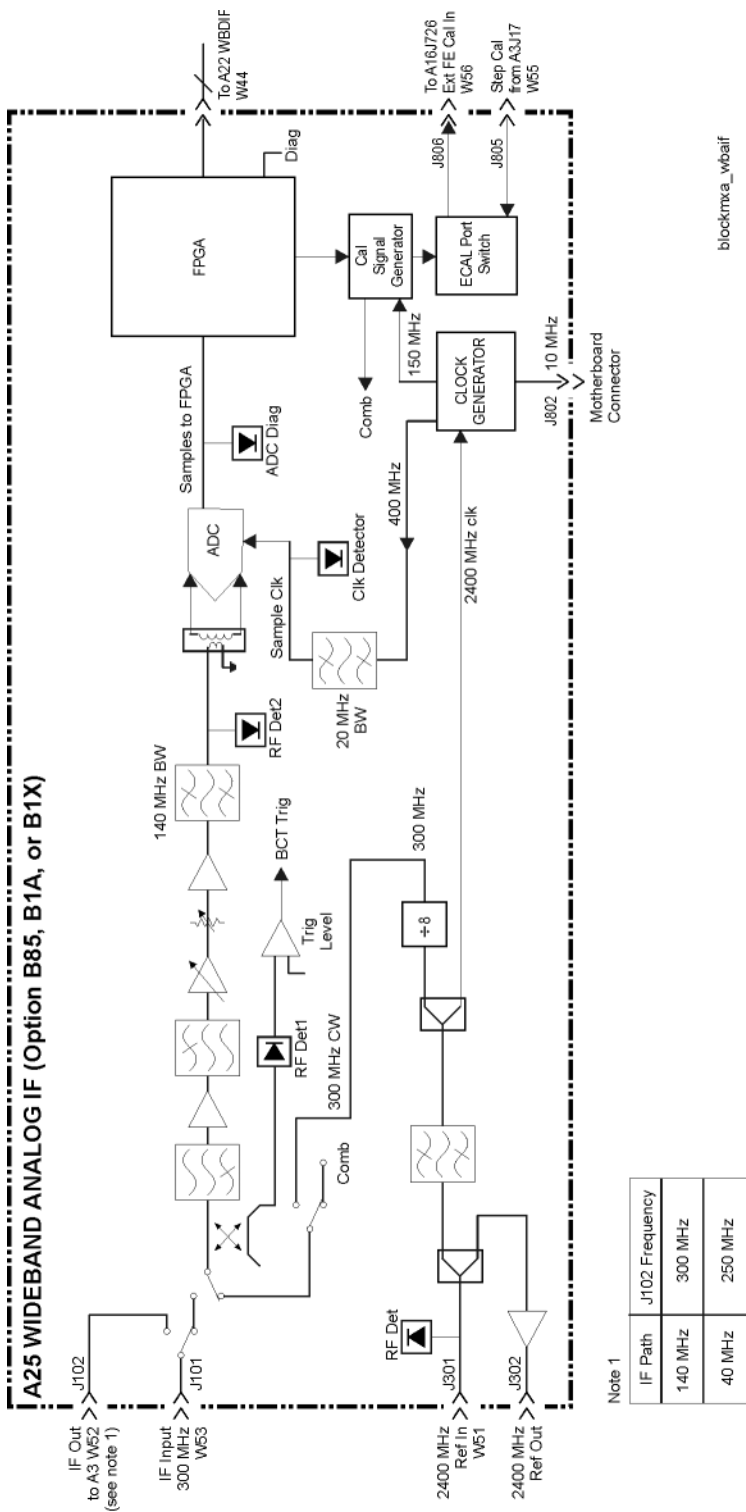


**FOOTNOTES**

- (1) Analyzers without any of the following options: B85, B1A, B1X
- (2) Analyzers with any of the following options: B85, B1A, B1X
- (3) W42 is used on serial prefix < MY/SG/US5233 ;  
W54 is used on serial prefix ≥ MY/SG/US5233 and all analyzers with Option B85, B1A, or B1X
- (4) This cable only used on analyzers with serial prefix < MY/SG/US5233  
without any of the following options: B85, B1A, B1X
- (5) Connection depends upon option and serial prefix.

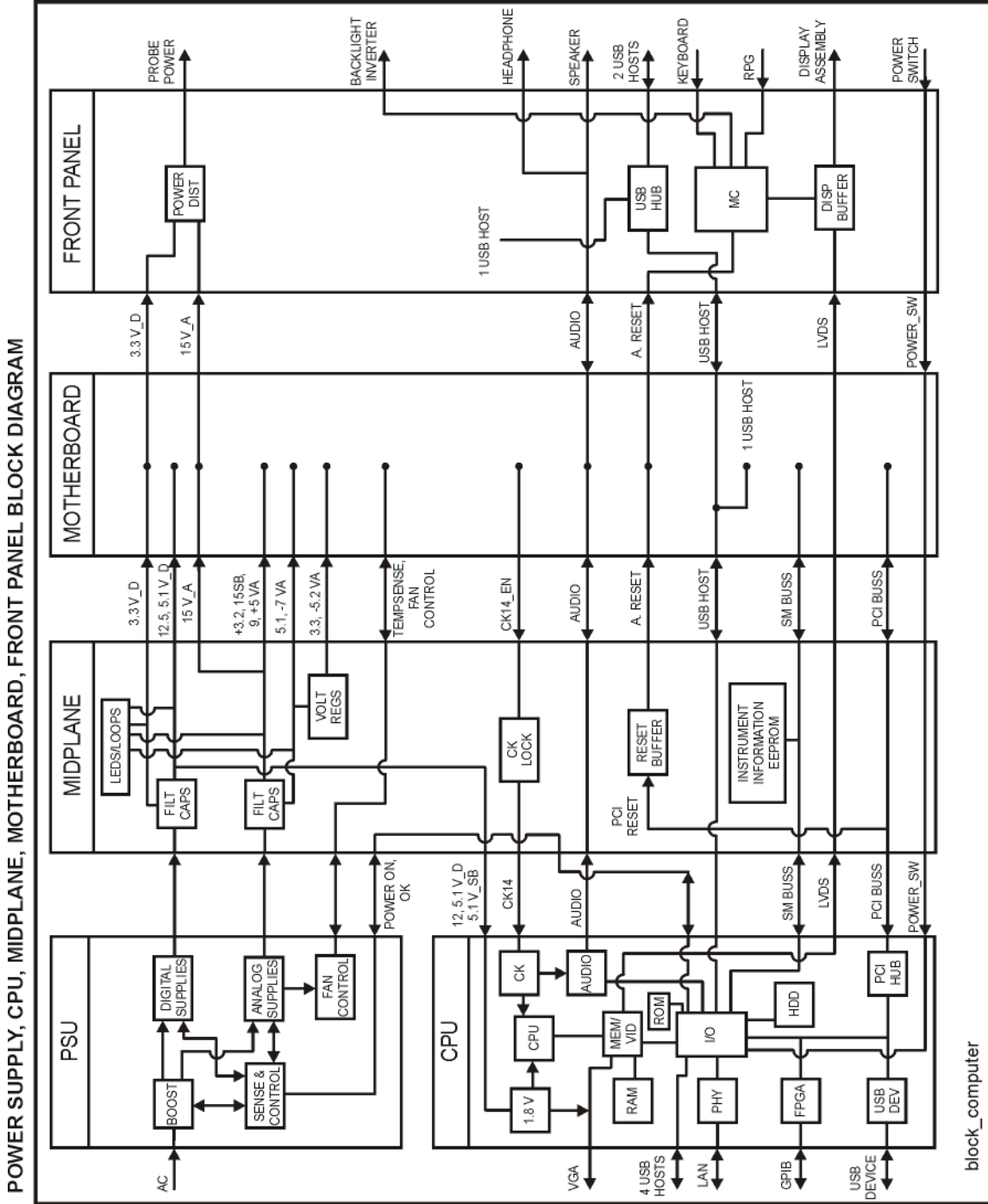
Serial Prefix	Option	Cable
<MY/SG/US5233	B40, DP2, or MPB	W40
any	B85, B1A, B1X	W55
≥MY/SG/US5233	B40, DP2, or MPB	W50

# ≥ 85 MHz Bandwidth IF System Block Diagram

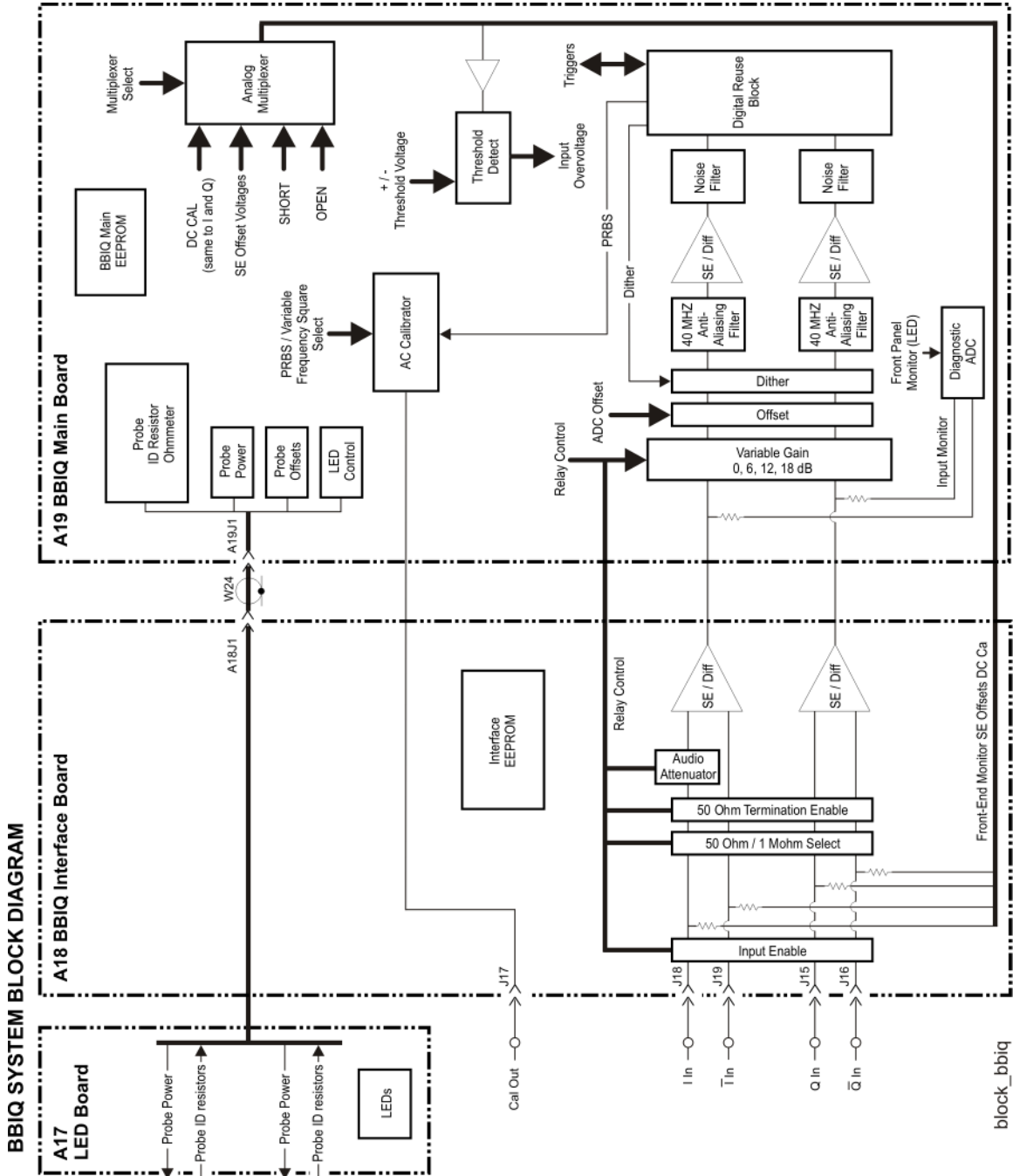




# MXA Computer Block Diagram



# BBIQ System Block Diagram



## 12 Service and Diagnostics Menus

### Overview

The Service capabilities described below are accessed via the Service and Diagnostic menus in the System menu. The Service capabilities are intended for field service technicians. These technicians may be at an Keysight Service Center or at a self-maintaining customer site.

There are two types of Service capabilities:

- 1. Diagnostics** - These are available to any user and will assist in initial troubleshooting of instrument malfunctions. Examples are the ability to read the mechanical relay cycles.
- 2. Service Functions** - These are for use by the factory or field repair technicians, access is controlled. Examples are the ability to band lock the analyzer and control the DAC which sets the 10 MHz Reference frequency.

### Controlling Access

There are two levels of service and diagnostics capabilities:

- 1. “Regular access”** to diagnostic capabilities that everyone is allowed access. Care may be required to use a feature appropriately. This is the “Diagnostic” type of Service capability defined above.
- 2. “Secure service access”** to the Service menu. This prevents the casual user from accessing and using these features. It is intended to provide this access to Keysight Service Centers or any customer who purchases the Service Guide. The “Service Functions” type of Service capability is defined above.

To access secured service capabilities the technician is required to enter a specific numeric Service Code that is controlled by the instrument software and, for older instrument software versions, Windows® Authentication (login). The Service Code is defined to be easily entered via the front panel; an external keyboard or mouse will not be required. Once access has been gained, it persists within the execution of the instrument application. If the user exits the instrument application, they must re-enter the Service Code to gain access.

## Secure Service Access, Software Versions A.01.xx through A.03.xx

Secure service access is the Windows® login of “advanceduser”. The “advanceduser” must be a member of the Power Users group. This account has not been pre-configured on the instrument. The administrator must create the login and make “advanceduser” a member of the Power Users group (refer to Windows XP Help and Support Center). Keysight recommend using the password “service4u” to ensure the analyzer can be supported by multiple people. The Service Code is “-2061”.

## Summary of Requirements for Service Menu Access, Software Versions A.01.xx through A.03.xx:

- User login name: advanceduser
- Recommended Password: service4u
- User is member of “Power Users” group
- Service Code: -2061

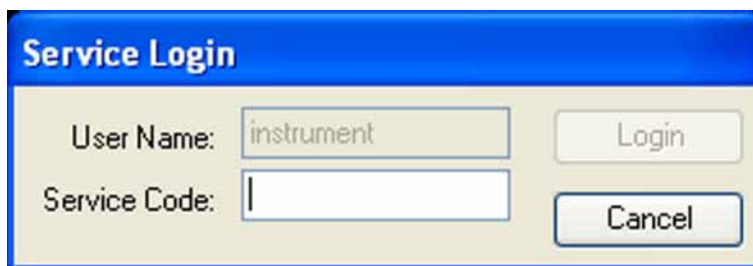
## Secure Service Access, Software Version $\geq$ A.04.00

To access the secure service capabilities press **System, More, Service** with the instrument application running. At this point you will see the window shown in **Figure 12-1**. Enter the Service Code and press **Enter**.

The Service Code is: -2061

Figure 12-1

Service Code Entry

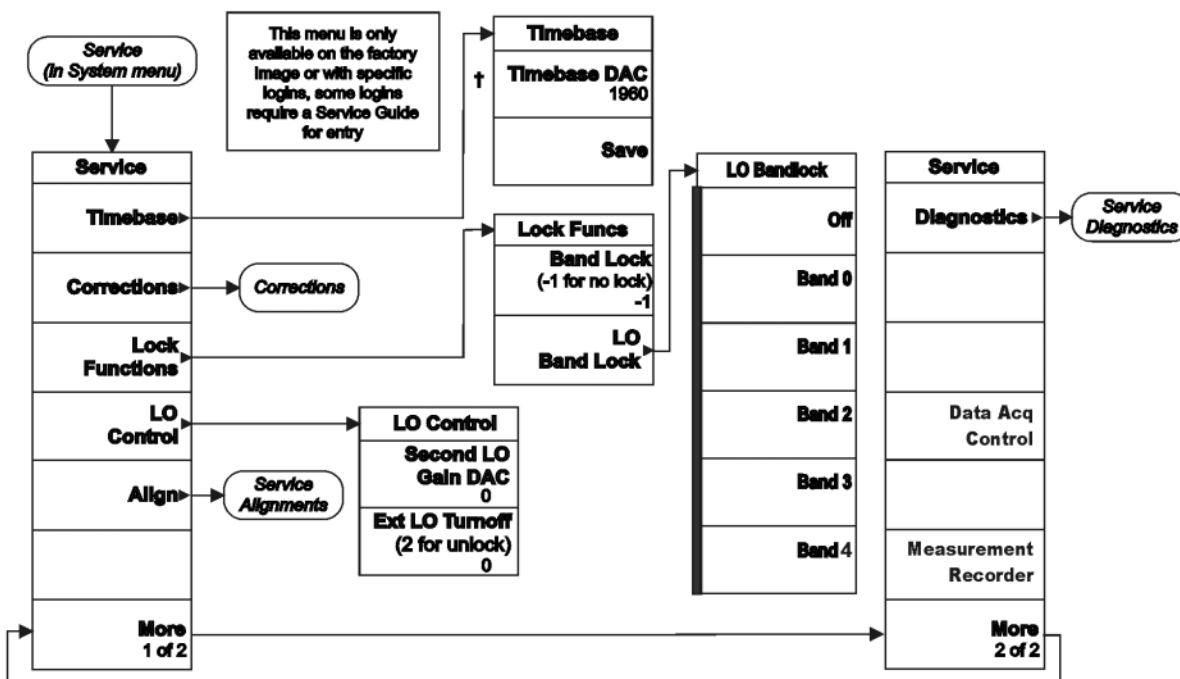


The image shows a dialog box titled "Service Login" with a blue header. It contains two input fields: "User Name" with the text "instrument" and "Service Code" which is currently empty. To the right of the "User Name" field is a "Login" button, and to the right of the "Service Code" field is a "Cancel" button.

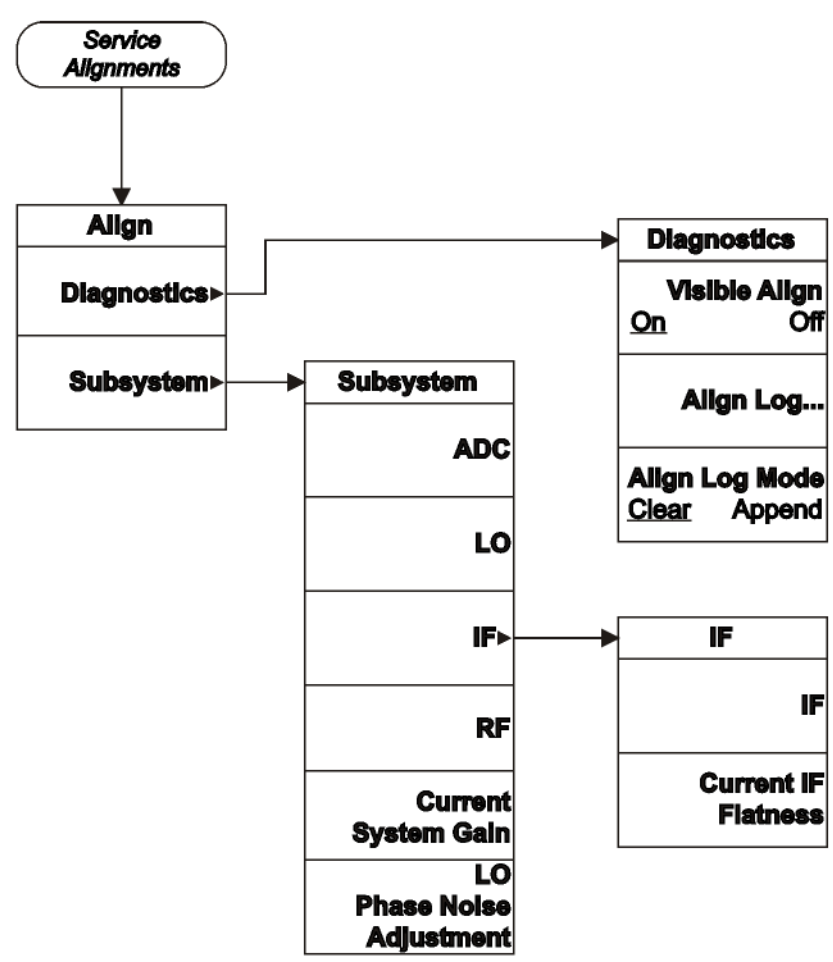
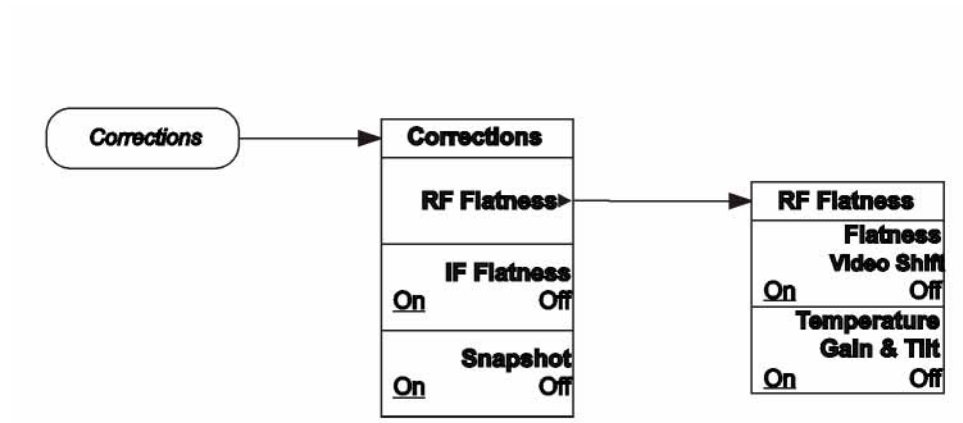
## Menus

### NOTE

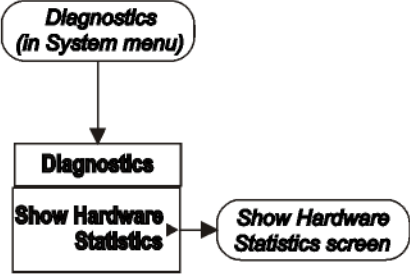
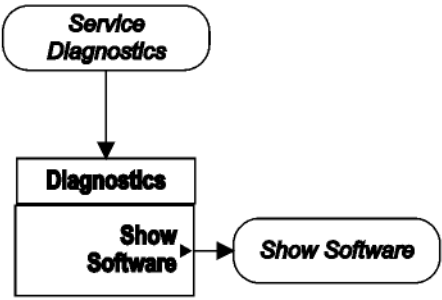
The menus shown on the following pages represent instrument software versions  $\geq$  A.13.00. The menus for earlier software versions are similar, but lack some of the features shown below.



Service and Diagnostics Menus



Service and Diagnostics Menu  
Menus



**Hardware Statistical Information**

MXA Signal Analyzer  
Product Number: N9020A  
Serial Number: US46220103  
Firmware Revision: A.01.00  
Revision Date: 10/18/2006 8:41:02 AM

Component Name	Value
MechAtten #1 Count Total	2091
50MHz Cal Switch	585
AC/DC Switch	438
1st 2dB Relay	498
2nd 2dB Relay	570
MechAtten #2 Count Total	2184
6dB Relay	555
10dB Relay	552
20dB Relay	606
30dB Relay	471
High temperature operating extreme	40
Low temperature operating extreme	0
Elapsed Time (On-Time)(hours)	137



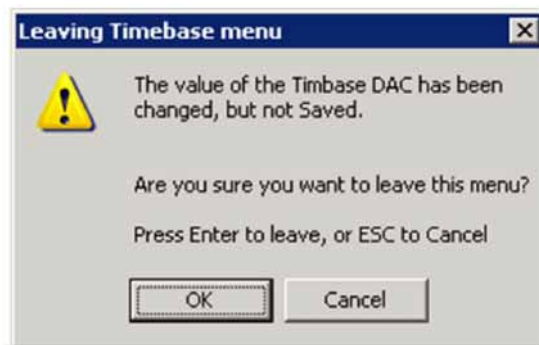
## Service Key Descriptions

### Timebase

Allows the technician to adjust the 10 MHz reference (“timebase”) manually.

**NOTE**

If the Timebase DAC value has been changed, but no Save operation performed before exiting this menu, a warning is provided to the user that they have not saved their setting:



### Timebase DAC

Allows the technician the ability to adjust the 10 MHz reference (“timebase”). The adjustment is performed by changing the DAC setting controlling the reference. Once the reference is adjusted to the proper frequency, the DAC value can be saved in non-volatile memory by pressing the Save menu key.

### Save

Saves the current Timebase DAC setting in the appropriate cal file. The operator is presented a prompt to confirm the operation:



## Corrections

The Corrections menu allows the technician to activate and deactivate specific amplitude correction sets. With this capability, the technician can determine if an anomaly is a result of raw hardware performance or incorrect correction data. It also allows the technician the ability to measure the raw hardware performance when all corrections are set to Off.

### **RF Flatness**

Displays a menu which allows the technician to activate and deactivate the corrections unique to the RF flatness of the analyzer. RF Flatness corrections consist of two major parts: raw flatness corrections and temperature corrections. These corrections are summed together and applied by using RF gain, IF gain, and/or “video shift” (post-digitized mathematical offset). The selections in this menu allow the corrections to be applied or not applied to facilitate troubleshooting the cause of flatness-related problems.

#### **Flatness Video Shift On/Off**

The Flatness Video Shift turns off the corrections for gain vs. frequency. It does not turn off the corrections for changes in the analog IF gain that accompany flatness changes. This function turns both the gain and video shift on or off, but does not affect the temperature corrections. When set to off, it is possible to measure the raw flatness of the spectrum analyzer while maintaining the temperature corrections.

When **Flatness Video Shift** is **Off**, the Advisory Event “Flatness Video Shift OFF” will be displayed.

When **Flatness Video Shift** is **ON**, the Advisory Event “Flatness Video Shift OFF” will be cleared.

#### **Temperature Gain & Tilt On/Off**

This function controls both temperature adjustment mechanisms: overall gain vs. temperature, and the temperature-proportional tilt of the gain vs. frequency.

When **Temperature Gain & Tilt** is **OFF**, the Advisory Event “Flatness Temperature Gain & Tilt OFF” will be displayed.

When **Temperature Gain & Tilt** is **ON**, the Advisory Event “Flatness Temperature Gain & Tilt OFF” will be cleared.

### **IF Flatness**

This function turns the corrections related to IF flatness On or Off.

When **IF Flatness** is **OFF**, the Advisory Event “IF Flatness corrections OFF” will be displayed.

When **IF Flatness** is **ON**, the Advisory Event “IF Flatness corrections OFF” will be cleared.

### **Snapshot Alignments On/Off**

During normal auto alignment operation, the firmware will perform an RBW and IQ alignment when the analyzer RBW state is changed, and every 10 minutes thereafter. These alignments can hinder troubleshooting the analyzer since they can change correction factors when the state is changed. Turning snapshot alignments off disables the RBW portion of these alignments for more accurate troubleshooting. (Use **IF Flatness ON/OFF** to control the IQ alignment.)

When **Snapshot Alignments** are **OFF**, the Advisory Event “Snapshot OFF” will be displayed.

When **Snapshot Alignments** are **ON**, the Advisory Event “Snapshot OFF” will be cleared.

## Band Lock

Provides the ability to tune the analyzer over as large a range as can be accommodated by the specified harmonic number and 1st LO frequency range. As a result, this feature can be used to check performance in the frequency band overlap regions. By definition, multi-band sweeps are not allowed.

When band lock is in effect the Advisory Event “Band Locked: Band <x>” where “x” is a value between 0 and 6.

When band lock is not in affect the Advisory Event “Band Locked: Band <x>” is cleared.

### **Dependencies/Couplings:**

1. Band Lock is only available on analyzers with frequency range options beyond 3.6 GHz
2. The individual bands available for selection also depends upon the particular frequency range option.

#### **Off** or value of -1

Turns Band Lock to Off. Analyzer will tune from band to band normally.

#### **Band 0** or value of 0

Locks the analyzer to Band 0.

#### **Band 1** or value of 1

Locks the analyzer to Band 1.

#### **Band 2** or value of 2

Locks the analyzer to Band 2.

#### **Band 3** or value of 3

Locks the analyzer to Band 3.

#### **Band 4** or value of 4

Locks the analyzer to Band 4.

#### **Band 5** or value of 5

Locks the analyzer to Band 5.

#### **Band 6** or value of 6

Locks the analyzer to Band 6.

## LO Band Lock

Provides the ability to tune the analyzer over as large a range as can be accommodated by the specified LO Band. As a result, this feature can be used to check performance in the LO band overlap regions. By definition, multi-band sweeps are not allowed.

When band lock is in effect the Advisory Event “LO Band Locked: Band <x>” where “x” is a value between 0 and 6.

When band lock is not in affect the Advisory Event “LO Band Locked: Band <x>” is cleared.

### **Dependencies/Couplings:**

LO Bandlock will be grayed-out if Bandlock is OFF. If Harmonic Bandlock is any setting other than OFF, LO Bandlock menu key is enabled. If LO Bandlock is other than OFF, and the Harmonic Bandlock is transitioned to OFF, the LO Bandlock is set to OFF.

#### **Off**

Turns LO Band Lock to Off. Analyzer will tune from LO band to LO band normally.

#### **Band 0**

Locks the analyzer to LO Band 0.

#### **Band 1**

Locks the analyzer to LO Band 1.

#### **Band 2**

Locks the analyzer to LO Band 2.

#### **Band 3**

Locks the analyzer to LO Band 3.

#### **Band 4**

Locks the analyzer to LO Band 4.

## LO Control

Provides keys that allow you to control the LO. This is only present on analyzers equipped with Option EXM, External Mixing.

### **2nd LO Gain DAC**

This parameter provides the ability to adjust the output gain of the 2nd LO DAC. The range is from 0 to 4095 where 0 is the minimum gain and 4095 is the maximum gain. Setting a value of 4096 or greater returns control to the instrument. In External Mixing, this DAC controls the level of the 1st LO signal at the front panel EXT MIXER connector.

## External LO Turnoff

Disconnects the 1st LO path which will minimize the effect of the 1st LO signal at the front panel EXT MIXER connector.

## Align

The Align Menu allows accessing Diagnostic capabilities of Alignment, and invoking alignments for individual subsystems.

### Diagnostic

The Diagnostic menu contains items for controlling the operating behavior of Alignment and the Alignment reporting capabilities.

#### Visible Align

Controls the state of Visible Align. Visible Align replaces the “Aligning 1 or 10” messages with descriptive messages describing the alignment piece begin executed.

#### Align Log...

Invokes Notepad with the Alignment Log loaded. The log can be viewed or saved to an external media or drive. Notepad can be closed without a mouse or external keyboard by pressing ALT front-panel key, then arrow down to highlight Exit, then press Enter.

#### Align Log Mode

The Alignment System places information about the last alignment performed into a log. The log can be configured to operate in clear or append mode. In clear mode the log only contains information on the last alignment performed; the log is cleared with each alignment performed. In append mode each new alignment appends to the log. In append mode, care must be taken by the operator to not allow the log to grow to a size so large as to inhibit system operation.

### Subsystem

The Subsystem menu allows invoking individual components of the internal alignments.

#### ADC

Immediately executes an alignment of the ADC subsystem. The instrument will stop any measurement currently underway, perform the alignment, then restart the measurement from the beginning.

A failure of ADC will set the Error Condition “Align ADC failed”. A failure will not employ new ADC alignment data.

Successful completion of ADC will clear the Error Condition “Align ADC failed”.

The Advisory Event “Alignment complete” is displayed when the alignment is complete.

Align ADC can be interrupted by pressing the Cancel (ESC) front-panel key. When this occurs, no new ADC alignment data will be employed.

### **LO**

Immediately executes an alignment of the LO subsystem. The instrument will stop any measurement currently underway, perform the alignment, then restart the measurement from the beginning.

A failure of LO will set the Error Condition “Align LO failed”. A failure will not employ new LO alignment data.

Successful completion of LO will clear the Error Condition “Align LO failed”.

The Advisory Event “Alignment complete” is displayed when the alignment is complete.

Align LO can be interrupted by pressing the Cancel (ESC) front-panel key. When this occurs, no new LO alignment data will be employed.

### **IF**

Immediately executes an alignment of the IF subsystem. The instrument will stop any measurement currently underway, perform the alignment, then restart the measurement from the beginning.

A failure of IF will set the Error Condition “Align IF failed”. A failure will not employ new IF alignment data.

Successful completion of IF will clear the Error Condition “Align IF failed” and clear bit 6 in the Status.

The Advisory Event “Alignment complete” is displayed when the alignment is complete.

Align IF can be interrupted by pressing the Cancel (ESC) front-panel key. When this occurs, no new IF alignment data will be employed.

### **Current IF Flatness**

Immediately executes an alignment of the Current IF Flatness, for the purpose of improving the absolute amplitude accuracy within FFT Sweeps and improving the group delay in some digital demodulation measurements. The instrument will stop any measurement currently underway, perform the alignment, then restart the measurement from the beginning.

The Advisory Event “Alignment complete” is displayed when the alignment is complete.

Align Current IF Flatness can be interrupted by pressing the **Cancel (ESC)** front-panel key. When this occurs, no new Current IF Flatness alignment data will be employed.

### **RF**

This is exactly the same as the customer accessible Align Now, RF with one exception: the alignment can be invoked even if a previous Align Now, All has not been executed (this key is not grayed-out if using default alignment data). See description of Align Now, RF in the User's Guide.

### **Current Gain System**

Immediately executes an alignment of the Current System Gain, for the purpose of improving small amplitude variations that occur as resolution bandwidth is switched. This alignment is done by measuring the response of the current system state configuration to the 50 MHz amplitude reference signal. All subsequent measurements are then compensated appropriately for absolute amplitude accuracy. The instrument will stop any measurement currently underway, perform the alignment, then restart the measurement from the beginning.

The Advisory Event "Alignment complete" is displayed when the alignment is complete.

Align Current System Gain can be interrupted by pressing the Cancel (ESC) front-panel key. When this occurs, no new Current System Gain alignment data will be employed.

### **LO Phase Noise Adjustment** (software versions $\geq$ A.04.00)

Immediately executes an optimization LO for Phase Noise. When the optimization is finished the value is stored in non-volatile memory. The instrument will stop any measurement currently underway, perform the alignment, and then restart the measurement from the beginning (similar to pressing the **Restart** key).

### **Diagnostics** (software versions $\geq$ A.04.00)

Pressing Diagnostics in the Service Menu brings up the Service Diagnostics submenu. The functions in this menu allow the technician to do more detailed, lower-level troubleshooting.

### **Show Software**

The Show Software screen displays revision information for Keysight internal software that comprises the embedded application and programmable hardware devices (FPGAs and PLDs).



Service and Diagnostics Menu  
 Service Key Descriptions

Figure 12-2 Example Screen

Software Assembly Name	Version
AcprMeasurement	1.3.47921.24555
ADemodApplication	1.3.47921.24555
ADemodLogicalLicense	1.0.1.1
ADemodMeasurement	1.3.47921.24555
ADemodPhysicalLicense	1.0.1.1
Agilent.Cdf.Api	3.5.12601.11917
Agilent.Cdf.DataAccess	2.2.9815.12243
Agilent.CommonBaseband.HWControl	2.6.9.0
Agilent.Lxi.LxiEventWrapper	1.0.6.0
Agilent.Physics	11.4.0.0
Agilent.Physics.AbortHandler	11.4.12.0
Agilent.Physics.CodeTimer	0.20.1.0
Agilent.Physics.LogicalHardware	11.4.12.0
Agilent.PhysicsServer	11.4.12.0
Agilent.PhysicsServices	0.20.1.0
Agilent.SA.Application	1.3.47921.24555
Agilent.SA.Application.ResourceCatalog	1.3.47921.24555
Agilent.SA.BackusDsp	3.14.0.0
Agilent.SA.BaseInst.ResourceCatalog	1.3.47921.24555
Agilent.SA.BaseInterfaces	1.3.47921.24555
Agilent.SA.Data	3.5.12601.11917
Agilent.SA.Dsp	1.3.47921.24555
Agilent.SA.DynamicTypes	0.0.0.0
Agilent.SA.GPSA.ResourceCatalog	1.3.47921.24555
Agilent.SA.GpsaCommon	1.3.47921.24555
Agilent.SA.GpsaDisplay	1.3.47921.24555
Agilent.SA.GpsaEngine	1.3.47921.24555
Agilent.SA.GPSAMeasurement	1.3.47921.24555
Agilent.SA.GpsaTypes	1.3.47921.24555
Agilent.SA.Graph	1.3.47921.24555
Agilent.SA.Graph.DrawEngine	1.2.3573.17385
Agilent.SA.GuiLibrary	1.3.47921.24555
Agilent.SA.HardwareLogicalLicenses	1.0.2.2
Agilent.SA.Hooks	3.5.12601.11917
Agilent.SA.IACUI	1.3.47921.24555
Agilent.SA.InstInterface	1.3.47921.24555

The software name is left justified, with the revision information right justified. This is a multi-page list with Next Page and Previous Page menu key control in accordance with other text screens (Show Systems, Show Errors, etc.).

Service and Diagnostics Menus  
Service Key Descriptions

## 13 Replaceable Parts

### What You Will Find in This Chapter

1. Part number tables for assemblies, mechanical parts, cables, front panel connectors, and labels.
2. Part location diagrams for the following:

Figure 13-1, “Major Assemblies,”

Figure 13-2, “External Hardware (Benchtop Configuration),”

Figure 13-3, “External Hardware and Bail Handle (Option PRC),”

Figure 13-4, “External Hardware (Option PRC),”

Fig 13-5 and Fig 13-6 CPU Assembly on [page 386](#) and [page 387](#)

Figure 13-7, “Disk Drive Tray Assembly,”

Figure 13-8, “Top Brace and Reference Bracket,”

Figure 13-9, “RF Area - Standard Instrument,”

Figure 13-10, “RF Area - Options B40, MPB, or DP2,”

Figure 13-11, “RF Area - Options B40, MPB, or DP2 (switch detail),”

Figure 13-12, “Front End Parts - Standard Instruments,”

Figure 13-13, “Front End Parts - Options MPB, B40, DP2, CR3, or CRP,”

Figure 13-14, “Front End Control Cables - early serial numbers,”

Figure 13-15, “Front End Control Cables - later serial numbers,”

Figure 13-16, “Front End Control Cables - Options B40, MPB, DP2, CR3, or CRP,”

Figure 13-17, “Reference Board Cables - Instruments without Option B40, MPB, DP2, B85, B1A, or B1X Serial Number < MY/SG/US52330000,”

Figure 13-18, “Reference Board Cables - Options B40, MPB, DP2 Serial Number < MY/SG/US52330000 without Options B85, B1A, or B1X,”

Figure 13-21, “AIF/DIF Cables - Standard Instruments,”

Figure 13-22, “AIF/DIF Cables, bottom - Standard Instruments,”

Figure 13-23, “AIF/DIF Cables - Options MPB, B40, or DP2,”

Replaceable Parts  
What You Will Find in This Chapter

Figure 13-24, "AIF/DIF Cables, bottom - Options MPB, B40, or DP2,"

Figure 13-25, "AIF/DIF Assemblies - Standard Instruments,"

Figure 13-26, "AIF/DIF Assemblies - Option DP2, MPB, B40,"

Figure 13-27, "Chassis,"

Figure 13-28, "Motherboard,"

Figure 13-29, "Fan Hardware,"

Figure 13-30, "Input Connector,"

Figure 13-31, "Front Frame Parts - LCD,"

Figure 13-32, "Front Frame Parts - LED,"

Figure 13-33, "Front Frame Parts (shields off) - LED,"

Figure 13-34, "Front Frame Exploded View - LCD,"

Figure 13-35, "Front Frame Exploded View - LED,"

Figure 13-36, "Option BBA Parts,"

## How to Order Parts

To order an assembly or mechanical part listed in this chapter, go to:  
[www.keysight.com/find/parts](http://www.keysight.com/find/parts)

If you do not have web access, or the parts you are interested in cannot be found in the parts list provided, contact your local Keysight Technologies sales and service office with the following information:

- Product model number
- Product serial number
- Description of where the part is located, what it looks like, and its function (if known)
- Quantity required

For a list of Keysight Technologies sales and service office locations, refer to **“Contacting Keysight Technologies” on page 39.**

## Replaceable Parts

Some of the assemblies listed in the following table are related to options that are available with the MXA Signal Analyzer. These options are described below.

Table 13-1 All Replaceable Parts

Reference Designator	Description	Part Number
A1A1	Front Frame Assembly Replacement Kit <sup>a</sup>	N9020-60110
A1A1MP1	Front Frame	W1312-20108 <sup>b</sup>
A1A1MP2	Main Keypad Overlay <sup>b</sup>	
	Serial Number >MY/SG51240000	N9020-60137
	Serial Number <MY/SG51240000	E4410-80108
A1A1MP3	Connector Overlay	E4410-80109
A1A1MP4	Front Frame Ground Spring	W1312-00021
A1A1MP5	Braided Gasket	-----
A1A1MP6	Chromeric Gasket	-----
A1A1MP7	Front Frame Top Trim Strip (Use with Option PRC, Portable)	W1312-40004
A1A1MP8	Front Frame Top Trim Strip (Use with standard Bench analyzer)	W1312-40019
A1A1MP9-10	Front Frame Side Trim Strip	W1312-40005
A1A1MP11-12	Vinyl Side Trim (Use with standard Bench Analyzer)	5041-9172
A1A1MP13-17	Hole Plug	6960-0525
A1A1MP18	Cover Plate	N9020-00002
A1A1MP19	Overlay, Left Display	N9020-80026
A1A1MP20	Overlay, BBIQ Bottom	N9020-80013
A1A1MP21	Overlay, BBIQ Top	N9020-80014
A1A1MP22-23	Hole Plug, for 0.25 inch hole	6960-0076
A1A2	Front Panel Interface Board	
	Serial Number $\geq$ MY/SG/US51240000	W1312-60137
	Serial Number $\geq$ MY48030101, $\geq$ SG48030001, $\geq$ US48010001 to Serial Number <MY/SG/US51240000	W1312-60042
	Serial Number < MY48030101, SG48030001, US48010001 <sup>c</sup>	N9020-60033
A1A2MP1	Speaker	9164-0453

Table 13-1 All Replaceable Parts

Reference Designator	Description	Part Number
A1A2MP2	Speaker Foam	W1312-40016
A1A3	Liquid Crystal Display	
	Serial Number $\geq$ MY/SG51240000	2090-0997
	Serial Number $<$ MY/SG51240000	2090-0911
A1A4	DC-DC Converter (LED display backlight power) Serial Number $>$ MY/SG/US51240000	0950-5235
	Inverter Board (Display Backlight Power) Serial Number $<$ MY/SG/US51240000	0950-4635
A1A5	Front Panel Daughter Board	N9020--63193 <sup>d</sup>
A1MP1	Main Keypad	E4410-40100
A1MP2	Display Keypad	E4410-40101
A1MP3	Frequency Label, 3.6 GHz	
	Standard Instrument	N9020-80093
	Option RT1 or RT2	N9020-80122
A1MP4	Frequency Label, 8.4 GHz	
	Standard Instrument	N9020-80094
	Option RT1 or RT2	N9020-80123
A1MP5	Frequency Label, 13.6 GHz	
	Standard Instrument	N9020-80095
	Option RT1 or RT2	N9020-80124
A1MP6	Frequency Label, 26.5 GHz	
	Standard Instrument	N9020-80096
	Option RT1 or RT2	N9020-80125
A1MP7	LCD Glass Filter	1000-1513
A1MP8	LCD Lens Gasket	W1312-40006
A1MP9	Knob	W1312-40017
A1MP10-13	Cable Clamp (Front Panel Cables)	1400-2225
A1MP14	Display Bracket	
	Serial Number $\geq$ MY/SG/US51240000	W1312-00145
	Serial Number $<$ MY/SG/US51240000	W1312-00023

Table 13-1 All Replaceable Parts

Reference Designator	Description	Part Number
A1MP15	Inverter Board Shield	W1312-00024
A1MP16	Inverter Top Shield (Option BBA) Serial Number < MY/SG/US51240000	N9020-00010
A1MP17	Inverter Bottom Shield (Option BBA) Serial Number < MY/SG/US51240000	N9020-00011
A1MP18	Core Bracket (Option BBA)	N9020-00012
A1MP19-20	Grommet (Option BBA) Serial Number < MY/SG/US51240000	0400-0385
A1MP21	Channel Grommet (Option BBA) Serial Number < MY/SG/US51240000	0400-0018
A1MP22	Cable Clamp (Option BBA)	1400-1439
A1MP23	Front Panel Interface/Speaker Bracket	N9020-00028
A1MP24	Magnetic Shield (Display Bracket to Front Panel Interface/Speaker Bracket)	N9020-00029
A1W1	Flex Circuit, Display to Front Panel Interface Board	
	Serial Number ≥ MY/SG/US51240000	W1312-60122
	Serial Number < MY/SG/US51240000	W1312-60010
A1W2	Power Cable, Front Panel Interface Board to Inverter Board	W1312-60011
A1W3	Power Cable, Front Panel Interface board to DC-DC Converter Serial Number ≥ MY/SG/US51240000	W1312-60130
A1W4	Power Cable, DC-DC Converter to Display Serial Number ≥ MY/SG/US51240000	W1312-60131
A2	Analog I.F. Assembly	
	Standard Instruments, Serial Number < MY/SG/US52330000	E4410-60104
	Standard Instruments, Serial Number ≥ MY/SG/US52330000	N9020-60011
	Options B40, MPB, or DP2	N9020-60011
A3	Digital I.F. Assembly	
	Standard Instruments	N9020-60119
	Options B40, MPB, or DP2, Serial Number < MY/SG/US52330000 without Option B85, B1A, or B1X	N9020-60165
	Options B40, MPB, or DP2, Serial Number ≥ MY/SG/US52330000 and all with Option B85, B1A, or B1X	N9020-60016



Table 13-1 All Replaceable Parts

Reference Designator	Description	Part Number
A3W1	Cable Assembly, Smart Noise Source (Wire Harness)	
	Standard Instruments	E4410-60163
	Options B40, MPB, or DP2	N9020-60090
A4	CPU Replacement Kit (w/o disk drive)	
	Serial Number < MY/SG/US49100000 (Single Core)	N9020-60031
	Serial Number $\geq$ MY/SG/US49100000 to < MY/SG/US52090000 or Option PC2 (Dual Core) <sup>e</sup>	N9020-60081
	Serial Number $\geq$ MY/SG/US52090000 or Option PC4 (High Performance Dual Core) <sup>e</sup>	N9020-60135
A4A1	Disk Drive Interconnect Board (PC2 and PC4 CPUs only)	W1312-63079
A4BT1	CPU Board Battery (CR2032)	1420-0356
A5	Disk Drive Replacement Kit	
	Serial Number < MY/SG/US49100000 (IDE)	N9020-60066
	Serial Number $\geq$ MY/SG/US49100000 or Option PC2, or Option PC4 with WinXP OS <sup>e</sup>	N9020-60125
	Serial Number $\geq$ MY/SG/US52090000 or Option PC4 with WES7 OS <sup>e</sup>	N9020-60202
A5MP1	Disk Drive Tray <sup>e</sup>	W1312-40078
A5MP2	Disk Drive Rear Panel <sup>e</sup>	W1312-00103
A5MP3	Disk Drive Assembly Handle <sup>e</sup>	1440-0421
A5W1	Disk Drive Ribbon Cable (used only with IDE drives)	8121-1611
A6	Power Supply	
	Standard Instruments	0950-4894
	Options B85, B1A, or B1X	0950-5012
A7	Midplane Assembly	N9020-63120
A8	Motherboard Assembly	N9000-66404
A9	RF Attenuator A (0 to 4 dB)	33360-60008
A10	RF Attenuator B (0 to 66 dB)	33321-60083

Table 13-1 All Replaceable Parts

Reference Designator	Description	Part Number
A11	Low Band Switch Assembly	
	Option 503	E4410-60121 <sup>f</sup>
	Options 508, 513, 526	E4410-60121
A12	YTF Preselector (except Option 503)	5087-7828
A12MP1	Gap Pad YTF Base	5022-7179
A13	RF Front End Assembly	
	Serial Number < MY/SG/US52330000	N9020-60189 <sup>g</sup>
	Serial Number MY/SG/US52330000 to MY/SG/US52339999	N9020-60183
	Serial Number ≥ MY/SG/US53280000 except Option EXM	N9020-60189 <sup>g</sup>
	Option EXM	N9020-60183
A13A1	Bandpass Filter	
	Serial Number < MY/SG/US52330000 without Option B40, MPB, DP2, CR3, or CRP	0955-1719
	Serial Number < MY/SG/US52330000 with Option B40, MPB, DP2, CR3, or CRP and all Serial Numbers ≥ MY/SG/US52330000	0955-2176
A13W1	Cable Assembly, A13J10 to A13A1 Input (Semi Rigid)	
	Serial Number < MY/SG/US52330000 without Option B40, MPB, DP2, CR3, or CRP	E4410-20176
	Serial Number < MY/SG/US52330000 with Option B40, MPB, DP2, CR3, or CRP	E6607-21178
	Serial Number MY/SG/US52330000 to MY/SG/US52339999	N9020-20229
	Serial Number ≥ MY/SG/US53280000 except Option EXM	E6607-21178
	Option EXM	N9020-20229
A13W2	Cable Assembly, A13J11 from A13A1 Output (Semi Rigid)	
	Serial Number < MY/SG/US52330000 without Option B40, MPB, DP2, CR3, or CRP	E4410-20177
	Serial Number < MY/SG/US52330000 with Option B40, MPB, DP2, CR3, or CRP	E6607-21179
	Serial Number MY/SG/US52330000 to MY/SG/US52339999	N9020-20231
	Serial Number ≥ MY/SG/US53280000 except Option EXM	E6607-21179
	Option EXM	N9020-20231

Table 13-1 All Replaceable Parts

Reference Designator	Description	Part Number
A13MP1	Spacer, Bandpass Filter Mounting Adapter (Options B40, MPB, DP2, CR3, or CRP)	E6607-25005
A14	L.O. Synthesizer Assembly	
	Serial Number < MY/SG/US52330000	E4410-60187
	Serial Number ≥ MY/SG/US52330000 except Option HP2	N9020-60118
	Option HP2	E4410-60187
A15	Front End Control Assembly	
	Standard Instruments, Serial Number ≥ MY51240512 or ≥ SG51240029	N9020-60098
	Standard Instruments, Serial Number < MY51240512 or < SG51240029	N9020-60127 <sup>c</sup>
	Options B40, MPB, DP2, CR3, CRP	N9020-60172
A16	Reference Assembly	
	Serial Numbers < MY/SG/US52330000 without Option B85, B1A, or B1X	E4410-60108
	Serial Numbers < MY/SG/US52330000 with Option B85, B1A, or B1X	N9020-60200
	Serial Numbers ≥ MY/SG/US52330000	N9020-60200
A17	BBIQ LED Board (Option BBA) <sup>h</sup>	N9020-63095
A18	BBIQ Interface Board (Option BBA)	N9020-60094
A19	BBIQ Main Board (Option BBA)	N9020-60093
A25	Wide-Band Analog IF Assembly (Option B85/B1A/B1X)	N9020-60044
A26	Wide-Band Digital IF Assembly (Option B85/B1A/B1X)	N9020-60047
AT1	Fixed Attenuator, 6 dB (Options B40, MPB, or DP2) (connects to SW2)	08493-60026
B1-B2	Fan	3160-4199
J1	Type-N (f) RF Input Connector Assembly	5002-0702
	EMI O-Ring 18.75 mm ID (used between RF Input Connector and Front Frame)	8160-1637
J2	EXT MIXER Connector (discard washer and nut, if supplied) (Option EXM)	1250-1666
MP1	Chassis Base	
	Serial Number < MY/SG/US52330000	E4410-00102
	Serial Number ≥ MY/SG/US52330000	N9020-00032

Table 13-1 All Replaceable Parts

Reference Designator	Description	Part Number
MP2	Chassis Side, Right (inner)	
	Serial Number < MY/SG/US52330000	W1312-00046
	Serial Number ≥ MY/SG/US52330000	W1312-00135
MP3	Chassis Side, Left (inner)	
	Serial Number < MY/SG/US52330000	W1312-00047
	Serial Number ≥ MY/SG/US52330000	W1312-00136
MP4	Midplane Bracket	W1312-00048
MP5	Chassis Front Bracket	
	Serial Number < MY/SG/US52330000	W1312-00049
	Serial Number ≥ MY/SG/US52330000	W1312-00098
MP6	Fan Bracket	
	Serial Number < MY/SG/US52330000	W1312-00133
	Serial Number ≥ MY/SG/US52330000	W1312-00137
MP7	Top Brace (includes foam strips)	N9020-60018
MP8	Chassis Side, Right (Outer, attaches to Low Band Switch bracket, Attenuator brackets, and Chassis bottom)	
	Serial Number < MY/SG/US50510001 <sup>i</sup>	E4410-00101
	Serial Number ≥ MY/SG/US50510001 to < MY/SG/US52330000	N9020-00031
	Serial Number ≥ MY/SG/US52330000	N9020-00034
MP9	Rear Panel Replacement Kit (includes foam strip)	
	Serial Number < MY/SG/US52330000 except Option B85, B1A, or B1X	N9020-60028
	Serial Number < MY/SG/US52330000 Option B85, B1A, or B1X	N9020-60149
	Serial Number ≥ MY/SG/US52330000 except Option B85, B1A, or B1X	N9020-60142
	Serial Number ≥ MY/SG/US52330000 Option B85, B1A, or B1X	N9020-60149
MP10	Label, AUX IF OUT (rear panel)	N9020-80081
MP11-12	Coax Cable Clips	5041-9690
MP13-15	Tie Wrap (For long semi-rigid cables)	1400-0249

Table 13-1 All Replaceable Parts

Reference Designator	Description	Part Number
MP16	Dress Cover (includes magnetic gasket)	
	Serial Number < MY/SG/US52330000	N9020-60020
	Serial Number ≥ MY/SG/US52330000	N9020-60141
MP17-20	Rear Feet (Benchtop Configuration)	5041-9611
MP21-22	Strap Handles (Benchtop Configuration)	N9020-60002
MP25-26	Fan Guard	3160-0281
MP27-34	Rivet, Fan Mounting (8 pieces)	0361-1272
MP35	Z-Bracket Power Supply to Chassis	W1312-00016
MP36-37	Attenuator Bracket	N9020-00052
MP38	Low Band Switch Assembly Bracket	
	Serial Number < MY/SG50510001 <sup>i</sup>	E4410-00109
	Serial Number ≥ MY/SG50510001	N9020-00023
MP39	O-ring, Type N (f) RF Input Connector	8160-1637
MP40	PC Board Plastic Guides (10 pieces)	W1312-40001
MP41-44	Front Bumpers (Option PRC, Portable Configuration)	W1312-40020
MP45-48	Rear Bumpers (Option PRC, Portable Configuration)	W1312-40021
MP49	Bail Handle (Option PRC, Portable Configuration)	W1312-60036
MP50	Front Panel Protective Cover (Option CVR)	W1312-40025
n/a	Front End Troubleshooting Kit	N9020-60005
n/a	Front End Troubleshooting Bd.	E4410-60115
MP51	CPU & Power Supply Guide Pin Grommets (8 pieces)	0400-0353
MP52	50 Ω Termination (for A13)	1810-0118
MP53	Spiral Wrap	0890-0025
MP54	Rear Frame Lock Washer (External Reference Cable)	2190-0102
MP55	Rear Frame Lock Nut (External Reference Cable)	0590-2332
MP57-60	Bottom Feet Hole Plugs (Option PRC, Portable Configuration)	W1312-40032
MP61-64	Strap Handle Plugs (Option PRC, Portable Configuration)	W1312-40024
MP65	Top Bracket, Reference Assembly (not used on Serial Numbers ≥ MY/SG/US52330000)	N9000-00104

Table 13-1 All Replaceable Parts

Reference Designator	Description	Part Number
MP66-69	Bottom Feet (Benchtop Configuration)	5041-9167
MP70-71	Tilt Stands (Benchtop Configuration)	1460-1345
MP72-75	Bottom Feet Key Locks (Benchtop Configuration)	5021-2840
MP76	Vibration Mount (Option BBA Core Bracket)	0460-2725
MP77	BBIQ Main Board Warning Label	N9020-80036
MP78	Cable Hold Down, 41 mm	5023-2095
MP79	Bracket, Preselector Bypass Switch 1 (Option MPG, on top of bottom switch)	E4410-00104
MP80	Bracket, Preselector Bypass Switch 2 (Option MPB, on top of top switch)	E4410-00110
MP81	Reserved	
MP82	Reserved	
MP83	Gusset, Chassis (near RF Input connector)	W1312-00093
MP84	Bracket, Reference Support	E4410-00108
SW1 & 2	Coaxial Switch (Options B40, MPB, or DP2)	N1810-60069
W1	Cable, Front Panel Interface Board to Motherboard (Ribbon)	
	Serial Number $\geq$ MY/SG48010101, US48010001 <sup>j</sup>	N9020-60036
	Serial Number $<$ MY/SG48010101, US48010001 <sup>k</sup>	E4410-60171
W2	Cable, Interconnect from A2J820 to A3J20	
	Standard Instruments	E4410-60162
	Option B40, MPB, DP2	N9020-60046
W3	Cable Assembly, A11J2 to A13J2 (Semi Rigid)	
	Serial Number $<$ MY/SG50510001 <sup>i</sup>	E4410-20162
	Serial Number $\geq$ MY/SG50510001	N9020-20101
W4	Cable Assembly, A14J740 to A13J4 (Semi Rigid)	N9020-20156
W5	Cable Assembly, A16J702 to A13J1 (Semi Rigid)	
	Serial Number $<$ MY/SG/US52330000	N9020-20155
	Serial Number $\geq$ MY/SG/US52330000	N9020-20064

Table 13-1 All Replaceable Parts

Reference Designator	Description	Part Number
W6	Cable Assembly, A16J703 to A14J200 (Semi Rigid)	
	Serial Number < MY/SG/US52330000	N9020-20154
	Serial Number ≥ MY/SG/US52330000	N9020-20033
W7	Cable Assembly, A12 Output to A13J9 (Semi Rigid)	N9020-20124
W8	Cable Assembly, A11J3 to A12 Input (Semi Rigid)	
	Serial Number < MY/SG50510001 <sup>i</sup>	E4410-20160
	Serial Number ≥ MY/SG50510001	N9020-20123
W9	Cable Assembly, A10 Output to A11J1 (Semi Rigid)	
	Serial Number < MY/SG50510001 <sup>i</sup>	E4410-20159
	Serial Number ≥ MY/SG50510001	N9020-20153
W10	Cable Assembly, J1 to A9 Input (Semi Rigid)	
	Serial Number < MY/SG50510001 <sup>i</sup>	E4410-20156
	Serial Number ≥ MY/SG50510001	N9020-20141
W11	Cable Assembly, A9 Output to A10 Input (Semi Rigid)	N9020-20142
W12	Cable Assembly, A16J710 to A3J14 (Flexible Coax)	8121-1401
W13	Cable Assembly, A2J601 to A3J15 (Flexible Coax)	8121-1411
W14	Cable Assembly, A16J711 to A2J300 (Flexible Coax)	8121-1401
W15	Cable Assembly, A13J7 to A2J100 (Flexible Coax)	8121-1400
W16	Cable Assembly, A9 & A10 to A15J801 or A15J102 (Ribbon Cable)	E4410-60157
W17	Cable Assembly, A13J12 to A15J104 (Ribbon Cable)	E4410-60156
W18	Cable Assembly, A11J4 to A15J103 or A15J700 (Ribbon Cable)	E4410-60160
W19	Cable Assembly, A16J701 to A9 Cal Signal Input/Port 2 (Semi Rigid)	
	Serial Number < MY/SG/US52330000	N9020-20157
	Serial Number ≥ MY/SG/US52330000	N9020-20065
W20	Cable Assembly, A13J6 to A16J705 (Flexible Coax)	8121-1400
W21	Reserved	

Table 13-1 All Replaceable Parts

Reference Designator	Description	Part Number
W22	Cable Assembly, A15J301 or A15J300 to A12J1 (Wire Harness)	
	Standard Instruments, Options 508, 513, 526 with Serial Numbers < MY51240512, < SG51240029, < US51240101	E4410-60158
	Standard Instruments, Options 508, 513, 526 with Serial Numbers ≥ MY51240512, ≥ SG51240029, ≥ US51240101	N9020-60059
	Options B40, MPB, DP2, CR3, or CRP	N9020-60059
W23	Cable Assembly, Ext. Reference Cable (rear frame) to A16J704 (Flexible Coax)	8121-1402
W24	Cable Assembly, A18J1, BBIQ Interface Board to A19J1, BBIQ Main Board (Ribbon Cable) (Option BBA)	8121-1683
W25	Cable Assembly, A19J101, BBIQ Main Board to A16J707 Reference Board (Flexible Coax) (Option BBA)	8121-1401
W26	Cable Assembly, A13J13 to A15J903 (Flexible Coax) Option EXM	8121-2027
W27	Cable Assembly, J2 (front panel) to W28 (Semi Rigid) Option EXM	N9020-20166
W28	Cable Assembly, W27 to A13J8 (Semi Rigid) Option EXM	N9020-20241
W29	Reserved	
W30	Cable Assembly, A15J801 to SW1 and SW2 (Wire Harness)	E4410-60159
W31	Cable Assembly, SW2 Center Port to A11J3 (Semi-rigid)	E4410-20161
W32	Cable Assembly, SW2 Port 2 to A12J2 (Semi-rigid)	E4410-20163
W33	Cable Assembly, SW1 Port 2 to A12J1 (Semi-rigid)	E4410-20165
W34	Cable Assembly, SW1 Center Port to A13J9 (Semi-rigid)	E4410-20164
W35	Cable Assembly, AT1 to SW1 Port 1 (Semi-rigid)	N9020-20210
W36	Cable Assembly, A15J902 to A13J7 (Flexible Coax)	8121-1862
W37	Cable Assembly, A15J900 to A2J100 (Flexible Coax)	8121-1401
W38	Cable Assembly, A15J901 to A3J15 (Flexible Coax)	8121-1861
W39	Cable Assembly, A15J1100 to Rear Panel Port 9 (Flexible Coax)	8121-2028
W40	Cable Assembly, A13J6 to A3J17 (Flexible Coax)	8121-1940
W41	Cable Assembly, A2J601 to A3J19 (Flexible Coax)	8120-8868
W42	Cable Assembly, A16J706 to A3J14 (Flexible Coax)	8121-1401
W43	Cable Assembly, A16J705 to A3J18 (Flexible Coax)	8121-1401
W44	Cable Assembly, A25J2 to A26J504 (Flex cable)	8121-1854



Table 13-1 All Replaceable Parts

Reference Designator	Description	Part Number
W45	Reserved	
W46	Reserved	
W47	Reserved	
W48	Reserved	
W49	Reserved	
W50	Cable Assembly, A16J726 to A3J17 (Flexible Coax)	8121-1401
W51	Cable Assembly, A16J718 to A25J301 (Flexible Coax)	8121-1401
W52	Cable Assembly, A25J102 to A3J15 (Flexible Coax)	8121-2288
W53	Cable Assembly, A15J901 to A25J101 (Flexible Coax)	8121-2292
W54	Cable Assembly, A16J716 to A3J14 (Flexible Coax)	8121-2288
W55	Cable Assembly, A25J805 to A3J17 (Flexible Coax)	8121-2290
W56	Cable Assembly, A16J726 to A25J806 (Flexible Coax)	8121-2291

- a. Frequency range label not included in kit. See A1MP3 - A1MP6
- b. Non-orderable item, see A1A1
- c. Replacement Kit
- d. Serial prefix < MY/SG/US5011 order N9020-60110 due to fit issue.
- e. Disk drive removable through rear panel.
- f. The E4410-60121 is the preferred replacement for the N9020-60255, Low Band Switch that may be installed in some N9020As with Option 503.
- g. This kit replaces RF Front End Assemblies with part numbers E4410-60154, E6607-61002, and E6607-61004.
- h. Does not include A1A1MP20 or A1A1MP21 overlays.
- i. Refer to part number for S/N > MY/SG 50510001 if the analyzer is equipped with Option B40, MPB, or DP2.
- j. Locking connector on both ends
- k. Locking connector, Motherboard only

**Table 13-2 Attaching Hardware**

<b>Attach</b>	<b>To</b>	<b>Qty</b>	<b>Part Number</b>	<b>Type</b>	<b>Tool</b>	<b>Torque</b>
Analog IF	Digital IF	3	0515-0372	M3 X 0.5 (8 mm long)	Torx T-10	9 inch-lbs
Analog IF (Top Shield)	Analog IF (Bottom Shield)	16	0515-0664	M3 X 0.5 (12 mm long)	Torx T-10	9 inch-lbs
Attenuators	Attenuator Bracket	2 per	0515-0372	M3 X 0.5 (8 mm long)	Torx T-10	9 inch-lbs
Attenuators	Chassis	2 per	0515-0372	M3 X 0.5 (8 mm long)	Torx T-10	9 inch-lbs
Bail Handle	Front Frame	4	0515-0435	M4 X 0.7 (14 mm long)	Torx T-20	21 inch-lbs
Bandpass Filter	Bandpass Filter Spacer	3	0515-0661	M2 X 0.4 (6 mm long)	Torx T-6	3 inch-lbs
Bandpass Filter Spacer	RF Front End Assembly	4	0515-0658	M2 X 0.4 (6 mm long)	Torx T-6	3 inch-lbs
BBIQ Flex Ribbon (Option BBA)	BBIQ Interface Board	2	N9020-2001 7	Hex Shoulder Screw 4-40	1/4" socket	4 inch-lbs
BBIQ Core Bracket (Option BBA)	BBIQ Inverter Shield Top	2	0515-0372	M3 X 0.5 (8 mm long)	Torx T-10	9 inch-lbs
BBIQ LED Board (Option BBA)	Front Frame	2	0515-1227	M3 X 0.5 (8 mm long)	Torx T-10	9 inch-lbs
BBIQ Interface Board (Option BBA)	Front Frame (side)	1	0515-1035	M3 X 0.5 (8 mm long)	Torx T-10	9 inch-lbs
Bracket, Preselector Bypass SW1	Low Band Switch Bracket	2	0515-1992	M2.5 X 0.45 (20 mm long)	Torx T-8	6 inch-lbs
Bracket, Preselector Bypass SW2	Low Band Switch Bracket	2	0515-1992	M2.5 X 0.45 (20 mm long)	Torx T-8	6 inch-lbs
Chassis Bottom	Chassis Sides, Midplane & Front Bracket	15	0515-0372	M3 X 0.5 (8 mm long)	Torx T-10	9 inch-lbs
Chassis Side (Right Outside)	Low Band Switch Bracket, Attenuator Brackets, Chassis bottom	7	0515-0372	M3 X 0.5 (8 mm long)	Torx T-10	9 inch-lbs
CPU Assembly	Chassis	6	0515-0372	M3 X 0.5 (8 mm long)	Torx T-10	9 inch-lbs
CPU Shield <sup>a</sup>	CPU & Hard Disk Drive	19	0515-5074	M3 X 0.5 (6 mm long)	Torx T-10	9 inch-lbs

Table 13-2 Attaching Hardware

Attach	To	Qty	Part Number	Type	Tool	Torque
CPU Shield	CPU Assembly	3	0515-0372	M3 X 0.5 (8 mm long)	Torx T-10	9 inch-lbs
		19	0515-1227	M3 X 0.5 (6 mm long)	Torx T-10	9 inch-lbs
DC-DC Converter	Display Bracket Serial Number >MY/SG51240000	2	0515-0430	M3 X 6.0	Torx T-10	9 inch-lbs
Digital IF	LVDS Connector	2	0515-4439	M2.5 X 6.0	Small Pozi	5 inch-lbs
Display	Display Bracket Serial Number >MY/SG51240000	4	0515-0372	M3 X 0.5 (8 mm long)	Torx T-10	9 inch-lbs
Display	Display Bracket Serial Number MY/SG51240000	4	0515-1934	M2.5 X 0.45 (6 mm long)	Torx T-8	5 inch-lbs
Display Bracket & Front Panel Interface/Speaker Bracket	Front Frame	7	0515-0372	M3 X 0.5 (8 mm long)	Torx T-10	9 inch-lbs
Disk Drive	Disk Drive Tray	4	0515-0372	M3 X 0.5 (8 mm long)	Torx T-10	9 inch-lbs
Disk Drive Interconnect	CPU Assembly	2	0515-0372	M3 X 0.5 (8 mm long)	Torx T-10	9 inch-lbs
Disk Drive Handle	Disk Drive Rear Panel	2	0515-1227	M3 X 0.5 (6 mm long)	Torx T-10	9 inch-lbs
Disk Drive Rear Panel	Disk Drive Tray	4	0515-2219	M2.5 X 0.45 (5 mm long)	Torx T-8	9 inch-lbs
External Reference BNC	Rear Panel	1	2190-0102	Lock Washer	n/a	n/a
External Reference BNC	Rear Panel	1	0590-2332	Hex Nut	9/16" Nut Driver	21 inch-lbs
Fan Assembly	Chassis	5	0515-0372	M3 X 0.5 (8 mm long)	Torx T-10	9 inch-lbs
Fan	Fan Bracket	8	0361-1272	Rivets	n/a	n/a
Front Bumpers (Opt. PRC)	Front Frame	8	0515-0435	M4 X 0.7 (14 mm long)	Torx T-20	21 inch-lbs
Front Chassis Bracket & Midplane Bracket	Chassis Sides	10	0515-0372	M3 X 0.5 (8 mm long)	Torx T-10	9 inch-lbs

Table 13-2 Attaching Hardware

Attach	To	Qty	Part Number	Type	Tool	Torque
Front Frame	Chassis	8	0515-1035	M3 X 0.5 (8 mm long)	Torx T-10	9 inch-lbs
Front Frame Bottom	Chassis	2 per	0515-1035	M3 X 0.5 (8 mm long)	Torx T-10	9 inch-lbs
Front Panel Assy.	Chassis	6	0515-1035	M3 X 0.5 (8 mm long)	Torx T-10	9 inch-lbs
Front Panel Daughter Board	Front Frame	3	0515-0372	M3 X 0.5 (8 mm long)	Torx T-10	9 inch-lbs
Front Panel Interface	Front Frame	13	0515-1521	M3 X 0.5 (5 mm long)	Torx T-10	9 inch lbs.
Inverter Board	Inverter Bracket	2	0515-0372	M3 X 0.5 (8 mm long)	Torx T-10	9 inch-lbs
Inverter Board (Option BBA)	Display Bracket	2	0515-0372	M3 X 0.5 (8 mm long)	Torx T-10	9 inch-lbs
Inverter Shield Top (Option BBA)	Inverter Shield Bottom	8	0515-0372	M3 X 0.5 (8 mm long)	Torx T-10	9 inch-lbs
Low Band Switch Assy.	Chassis	2	0515-0372	M3 X 0.5 (8 mm long)	Torx T-10	9 inch-lbs
Low Band Switch Assy.	Low Band Switch Bracket	4	0515-0372	M3 X 0.5 (8 mm long)	Torx T-10	9 inch-lbs
Low Band Switch Bracket.	Bracket, Preselector Bypass SW2	1	0515-0372	M3 X 0.5 (8 mm long)	Torx T-10	9 inch-lbs
Midplane Assembly	Midplane Bracket	6	0515-0375	M3 X 0.5 (16 mm long)	Torx T-10	9 inch-lbs
Motherboard	Chassis Base	4	0515-0372	M3 X 0.5 (8 mm long)	Torx T-10	9 inch-lbs
Power Supply 'Z' Bracket	Chassis Sides	2	0515-0372	M3 X 0.5 (8 mm long)	Torx T-10	9 inch-lbs
Power Supply 'Z' Bracket	Power Supply	3	0515-1227	M3 X 0.5 (8 mm long)	Torx T-10	9 inch-lbs
Rear Bumper Feet (Opt. PRC)	Rear Panel	4	0515-1619	M4 X 0.7 (25 mm long)	Torx T-20	21 inch-lbs.
Rear Bumper Feet (Opt. PRC)	Rear Panel	4	3050-0893	Flat Washer	n/a	n/a
Rear Feet	Rear Panel	4	0515-1619	M4 X 0.7 (25 mm long)	Torx T-20	21 inch-lbs
Rear Feet	Rear Panel	4	3050-0893	Flat Washer	n/a	n/a

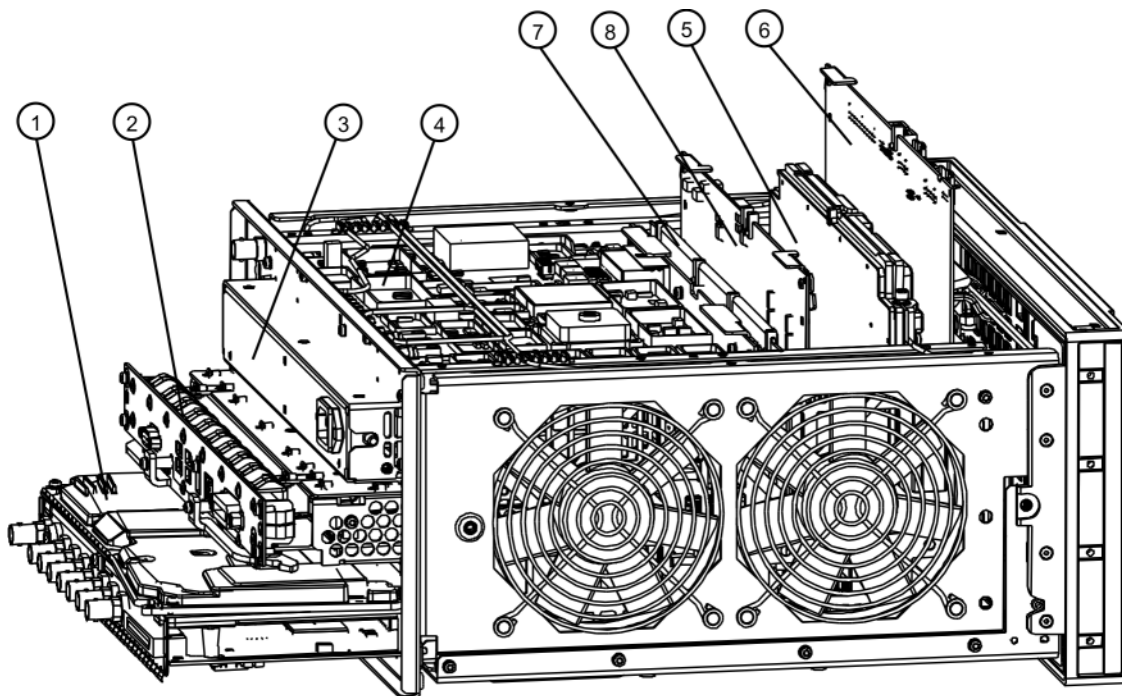
**Table 13-2 Attaching Hardware**

<b>Attach</b>	<b>To</b>	<b>Qty</b>	<b>Part Number</b>	<b>Type</b>	<b>Tool</b>	<b>Torque</b>
Rear Frame	Chassis	18	0515-0372	M3 X 0.5 (8 mm long)	Torx T-10	9 inch-lbs
Rear Frame	Top Bracket, Reference Assembly	4	0515-1227	M3 X 0.5 (8 mm long)	Torx T-10	9 inch-lbs
RF Front End Assembly	Chassis	4	0515-0372	M3 X 0.5 (8 mm long)	Torx T-10	9 inch-lbs
RF Input Connector	Chassis	2	0515-0372	M3 X 0.5 (8 mm long)	Torx T-10	9 inch-lbs
Strap Handle Plugs (Opt. PRC)	Instrument Cover	4	0515-5209	M5 X 0.8 (14 mm long)	Torx T-20	21 inch-lbs
Strap Handles	Chassis Side	2 per	0515-0710	M4 X 0.8 (18 mm long)	Torx T-20	21 inch-lbs
SW1 Bracket	SW1	2	0515-1992	M2.5 X 0.45 (20 mm long)	Torx T-8	6 inch-lbs
SW2 Bracket	SW2	2	0515-1992	M2.5 X 0.45 (20 mm long)	Torx T-8	6 inch-lbs
SW2 Bracket	Low Band Switch Bracket	1	0515-0372	M3 X 0.5 (8 mm long)	Torx T-10	9 inch-lbs
Top Brace	Top Bracket, Reference Assembly	4	0515-1227	M3 X 0.5 (6 mm long)	Torx T-10	9 inch-lbs
Top Brace	Board Assemblies	6	0515-1227	M3 X 0.5 (6 mm long)	Torx T-10	9 inch-lbs
Top Brace & Reference Assembly Bracket	Chassis Components	12	0515-0372	M3 X 0.5 (8 mm long)	Torx T-10	9 inch-lbs
YTF Preselector	Chassis	4	0515-0372 (except Option 503)	M3 X 0.5 (8 mm long)	Torx T-10	9 inch-lbs

a. Prior to serial number MY/SG/US49100000

## Hardware

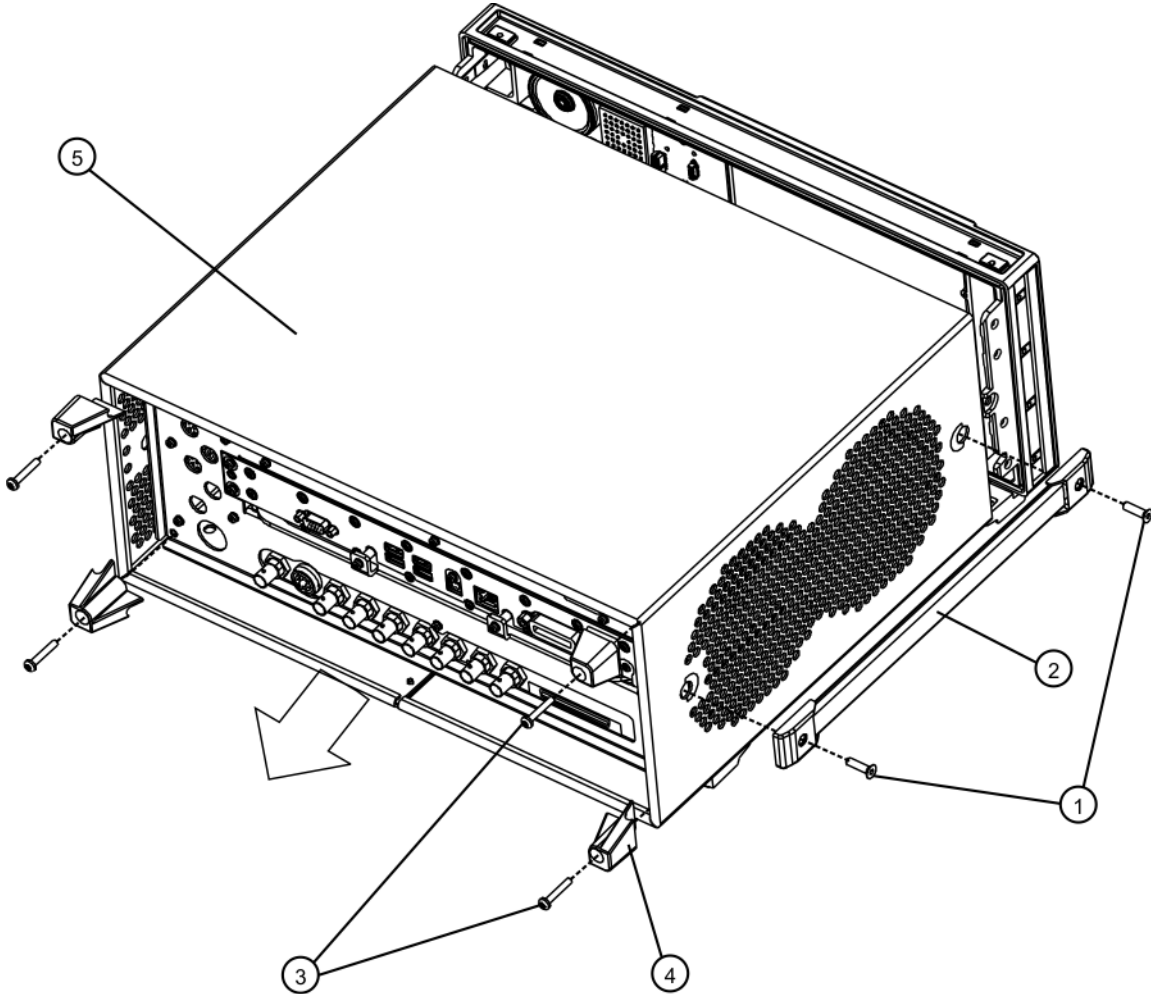
Figure 13-1 Major Assemblies



major assy  
Table 13-3

Item	Description	Keysight Part Number
1	A2 Analog I.F. Assembly A3 Digital I.F. Assembly	See <a href="#">Table 13-1</a>
2	A4 <b>CPU Replacement Kit (w/o disk drive)</b>	See <a href="#">Table 13-1</a>
3	A6 Power Supply	
	<b>Standard Instruments</b>	<b>0950-4894</b>
	<b>Options B85, B1A, or B1X</b>	<b>0950-5012</b>
4	A16 Reference Assembly	See <a href="#">Table 13-1</a>
5	A14 L.O. Synthesizer Assembly	See <a href="#">Table 13-1</a>
6	A15 Front End Control Assembly	See <a href="#">Table 13-1</a>
7	A7 Midplane Assembly	<b>N9020-63120</b>
8	A19 BBIQ Main Board (Option BBA)	<b>N9020-60093</b>

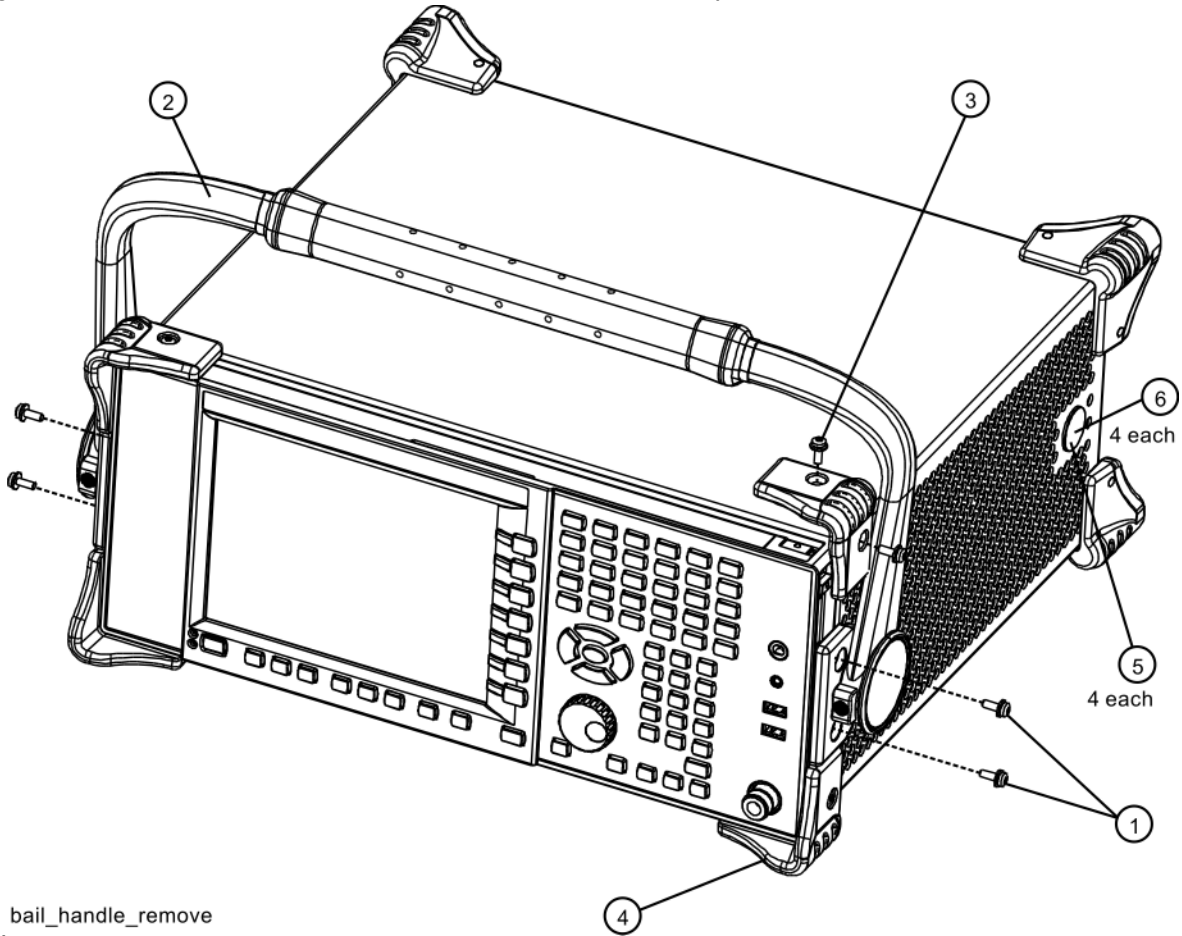
Figure 13-2 External Hardware (Benchtop Configuration)



outer\_case  
Table 13-4

Item	Description	Keysight Part Number
1, 2	MP21-22 Strap Handles (Benchtop Configuration) (includes screws)	N9020-60002
3	Screw M4 X 0.7 (25 mm long)	0515-1619
4	MP17-20 Rear Feet (Benchtop Configuration)	5041-9611
5	MP16 Dress Cover (includes magnetic gasket)	
	Serial Number < MY/SG/US52330000	N9020-60020
	Serial Number ≥ MY/SG/US52330000	N9020-60141

Figure 13-3 External Hardware and Bail Handle (Option PRC)



bail\_handle\_remove  
Table 13-5

Item	Description	Keysight Part Number
1	Screw <b>M4 X 0.7 (14 mm long)</b>	<b>0515-0435</b>
2	<b>MP49 Bail Handle (Option PRC, Portable Configuration)</b>	<b>W1312-60036</b>
3	Screw <b>M4 X 0.7 (14 mm long)</b>	<b>0515-0435</b>
4	<b>MP41-44 Front Bumpers (Option PRC, Portable Configuration)</b>	<b>W1312-40020</b>
5	<b>MP61-64 Strap Handle Plugs (Option PRC, Portable Configuration)</b>	<b>W1312-40024</b>
6	Screw <b>M5 X 0.8 (14 mm long)</b>	<b>0515-5209</b>



Figure 13-4 External Hardware (Option PRC)

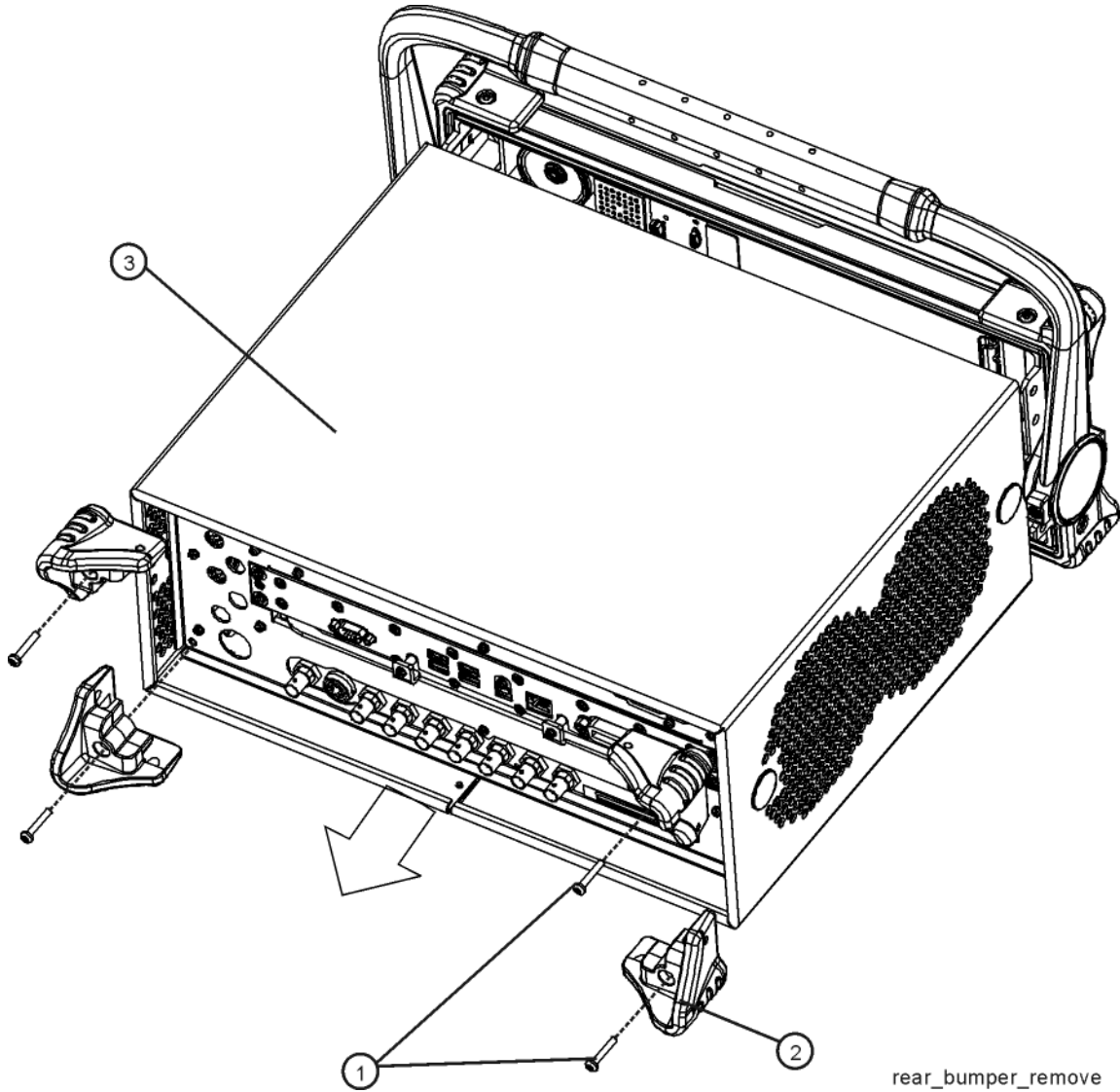


Table 13-6

Item	Description	Keysight Part Number
1	Screw <b>M4 X 0.7 (25 mm long)</b>	<b>0515-1619</b>
2	<b>MP45-48 Rear Bumpers (Option PRC, Portable Configuration)</b> (includes screws)	<b>W1312-40021</b>
3	<b>MP16 Dress Cover (includes magnetic gasket)</b>	
	<b>Serial Number &lt; MY/SG/US52330000</b>	<b>N9020-60020</b>
	<b>Serial Number ≥ MY/SG/US52330000</b>	<b>N9020-60141</b>

Figure 13-5 CPU Assembly (Serial Number < MY/SG/US49100000)

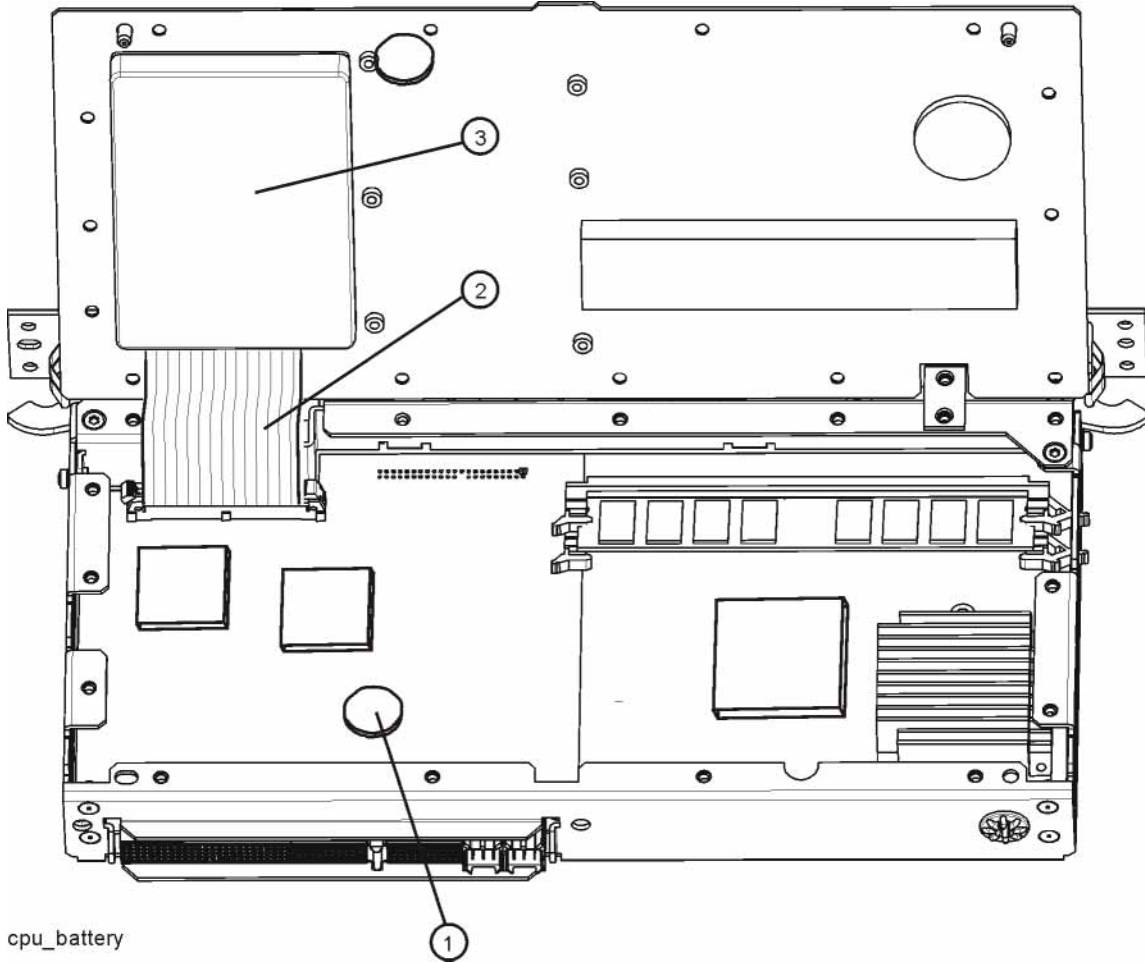
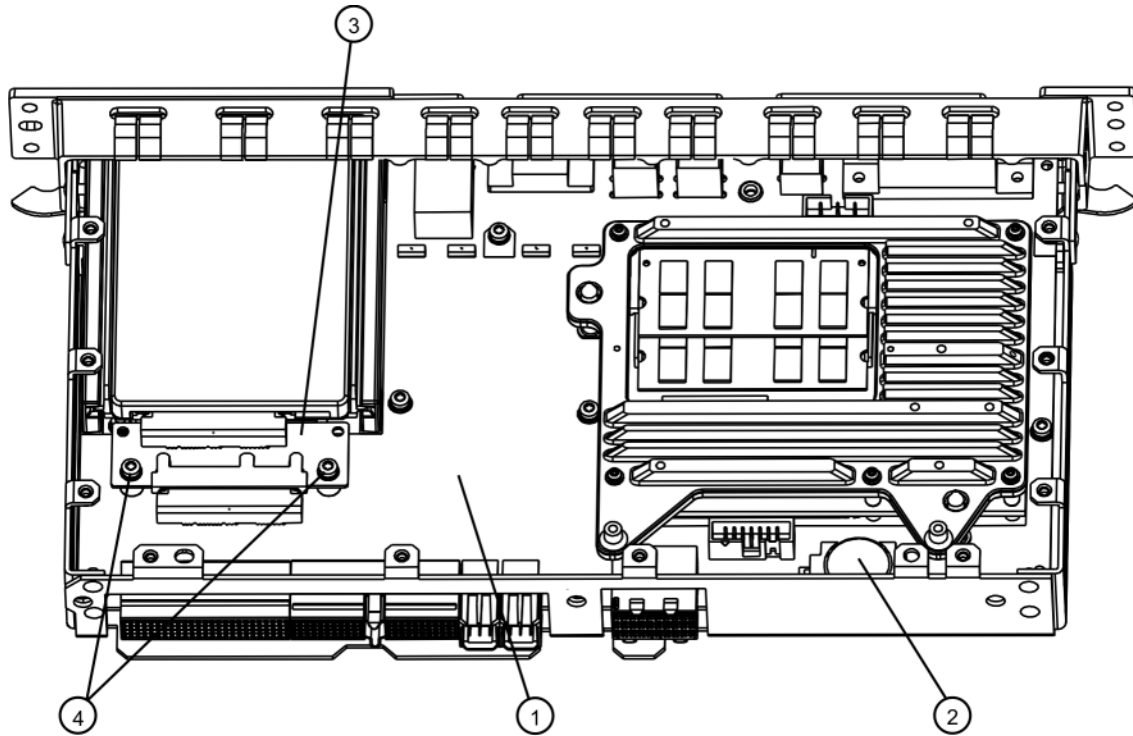


Table 13-7

Item	Description	Keysight Part Number
1	A4BT1 CPU Board Battery (CR2032)	1420-0356
2	Disk Drive Ribbon Cable (used only with IDE drives)	8121-1611
3	Hard Disk Drive	N9020-60066

Figure 13-6 CPU Assembly (Serial Number > MY/SG/US49100000)

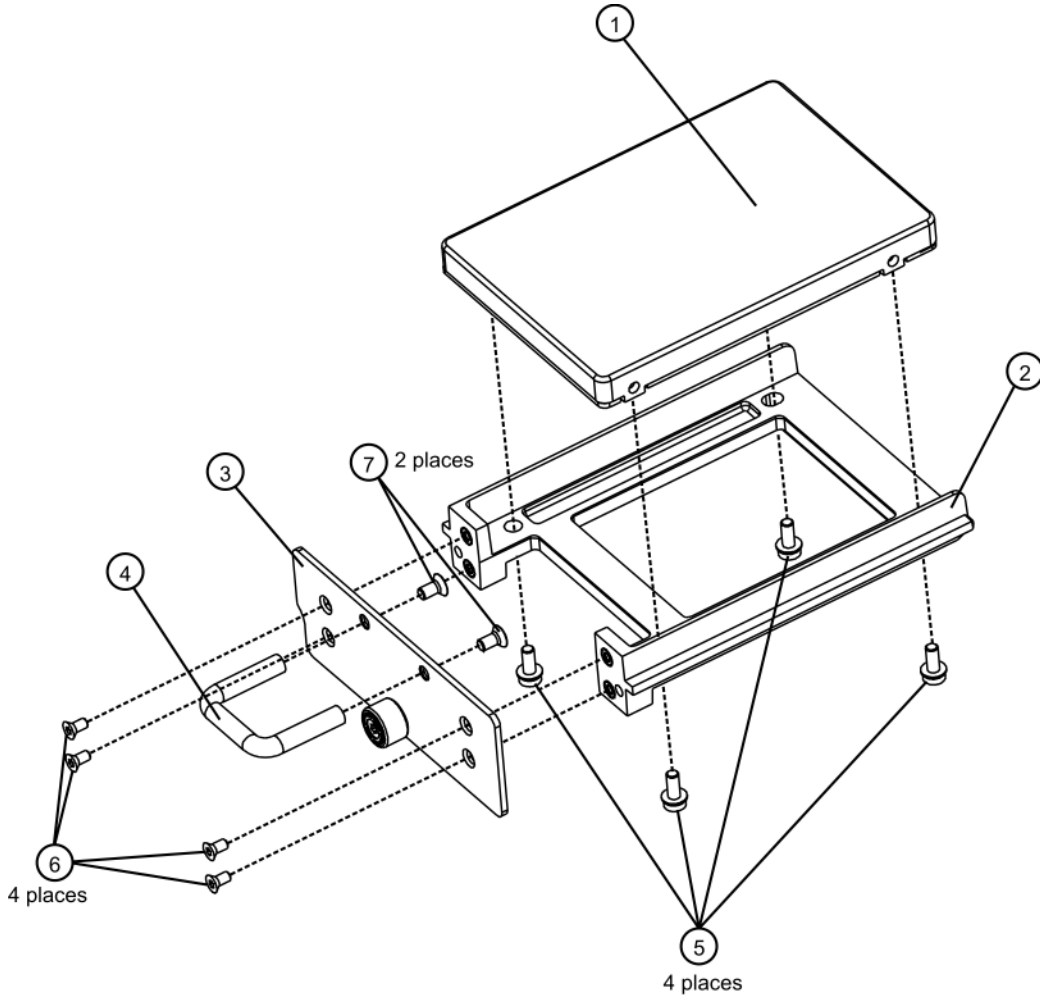


cpu\_nocover

Table 13-8

Item	Description	Keysight Part Number
1	<b>A4</b> CPU Replacement Kit	Refer to Service Note N9020A-01
2	<b>A4BT1</b> CPU Board Battery (CR2032)	<b>1420-0356</b>
3	<b>A4A1</b> Disk Drive Interconnect Board (PC2 and PC4 CPUs only)	<b>W1312-63079</b>
4	Screw M3 x 0.5 (8 mm long)	0515-0372

Figure 13-7 Disk Drive Tray Assembly



hdtray\_explode

Table 13-9

Item	Description	Keysight Part Number
1	<b>A5 Disk Drive Replacement Kit</b>	
	Serial Number < MY/SG/US49100000 (IDE)	<b>N9020-60066</b>
	Serial Number ≥ MY/SG/US49100000 or Option PC2 or Option PC4 with WinXP OS	<b>N9020-60125</b>
	Serial Number ≥ MY/SG/US52090000 or Option PC4 with WES7 OS	<b>N9020-60202</b>
2	<b>A5MP1</b> Disk Drive Tray	<b>W1312-40078</b>
3	<b>A5MP2</b> Disk Drive Rear Panel	<b>W1312-00103</b>
4	<b>A5MP3</b> Disk Drive Assembly Handle	<b>1440-0421</b>

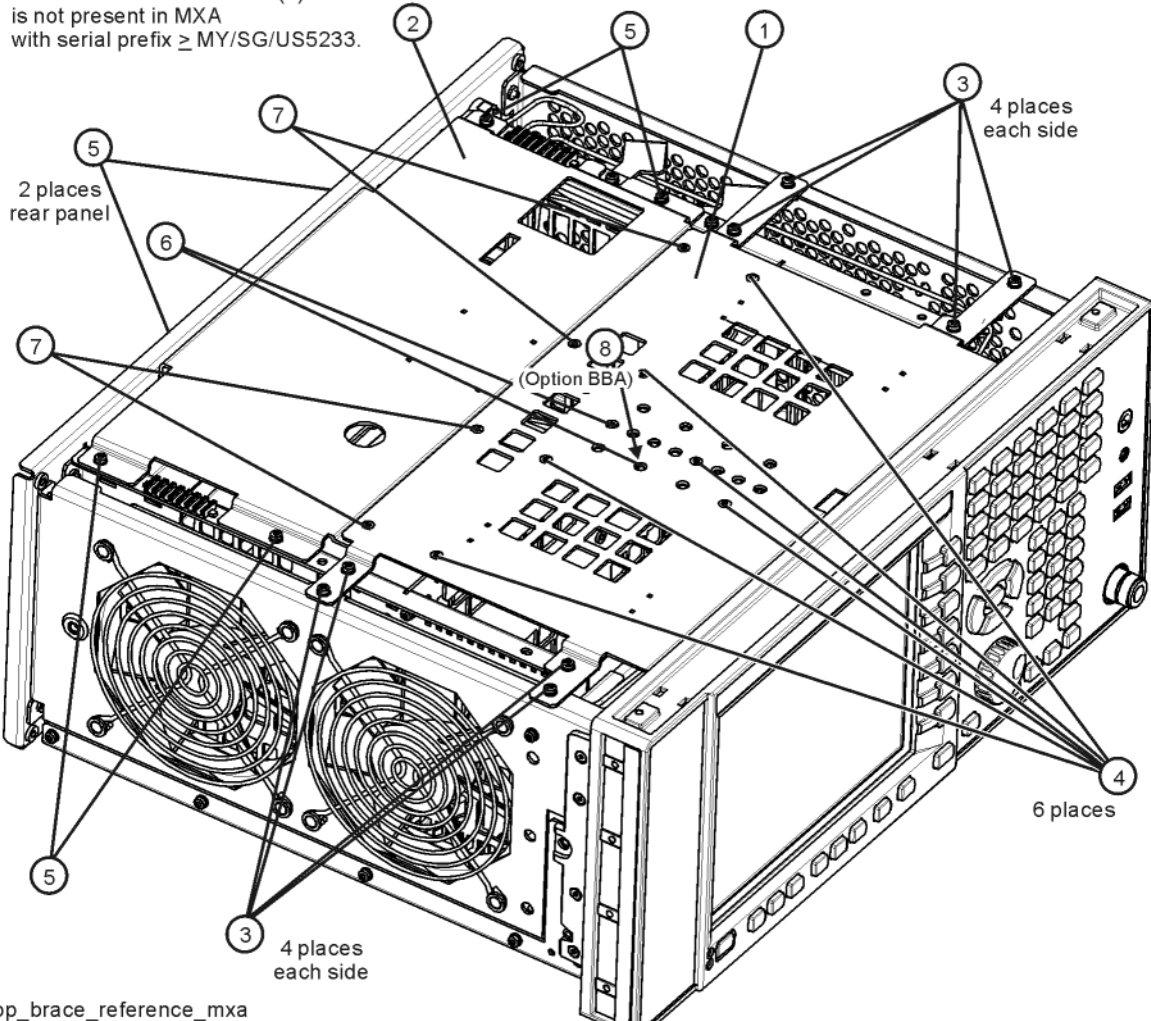
Replaceable Parts  
Hardware

Table 13-9

Item	Description	Keysight Part Number
5	Screw M3 x 0.5 (8 mm long) (For rev 6 and earlier of drive tray. For rev 7 and later, us 0515-1035 M3 (8 mm Flat-HD))	0515-0372
6	Screw M2.5 x 0.45 (5 mm long)	0515-2219
7	Screw M3 x 0.5 (6 mm long)	0515-1227

Figure 13-8 Top Brace and Reference Bracket

**NOTE:** Reference Bracket (2) is not present in MXA with serial prefix  $\geq$  MY/SG/US5233.



top\_brace\_reference\_mxa  
Table 13-10

Item	Description	Keysight Part Number
1	MP7 Top Brace (includes foam strips)	N9020-60018
2	MP65 Top Bracket, Reference Assembly (not used on Serial Numbers $\geq$ MY/SG/US52330000)	N9000-00104
3	Screw M3 X 0.5 (8 mm long)	0515-0372
4	Screw M3 X 0.5 (6 mm long)	0515-1227
5	Screw M3 X 0.5 (8 mm long)	0515-0372
6	Screw M3 X 0.5 (6 mm long)	0515-1227
7	Screw M3 X 0.5 (6 mm long)	0515-1227

Replaceable Parts  
Hardware

Table 13-10

Item	Description	Keysight Part Number
8	Screw <b>M3 X 0.5 (6 mm long)</b>	<b>0515-1227</b>

Figure 13-9 RF Area - Standard Instrument

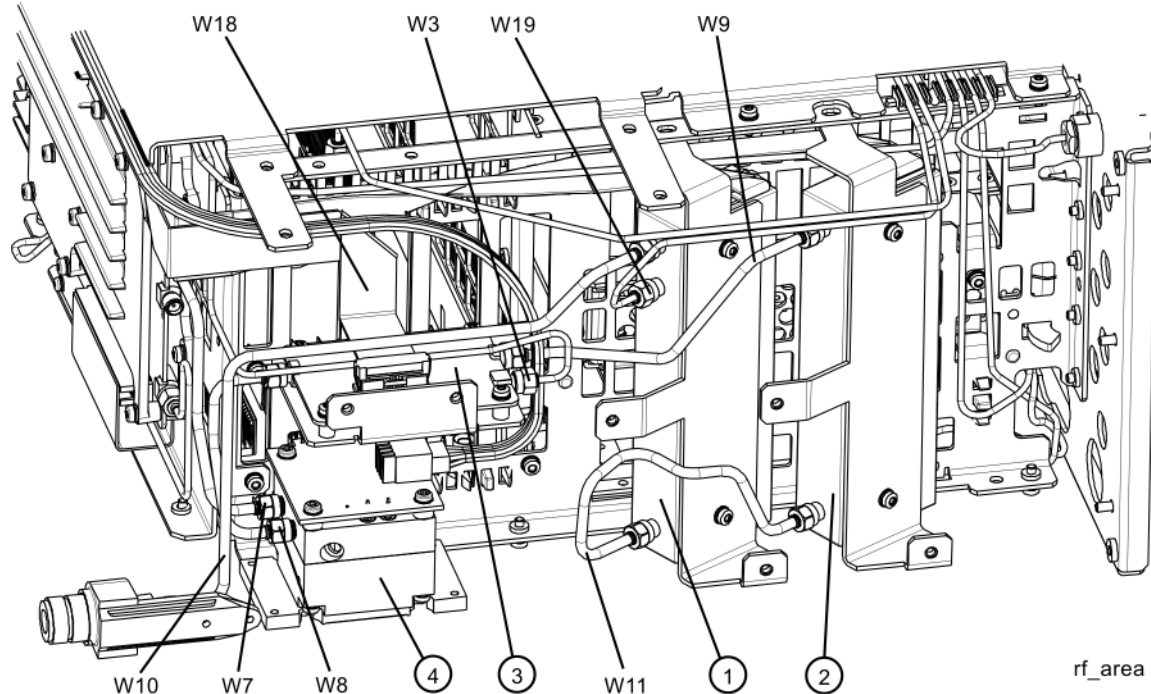


Table 13-11

Item	Description	Keysight Part Number
1	A9 RF Attenuator A (0 to 4 dB)	33360-60008
2	A10 RF Attenuator B (0 to 66 dB)	33321-60083
3	A11 Low Band Switch Assembly	E4410-60121
4	A12 YTF Preselector (except Option 503)	5087-7828
W3	Cable Assembly, A11J2 to A13J2 (Semi Rigid)	
	Serial Number < MY/SG50510001	E4410-20162
	Serial Number ≥ MY/SG50510001	N9020-20101
W7	Cable Assembly, A12 Output to A13J9 (Semi Rigid)	N9020-20124



Table 13-11

Item	Description	Keysight Part Number
W8	<b>Cable Assembly, A11J3 to A12 Input (Semi Rigid)</b>	
	Serial Number < MY/SG50510001	E4410-20160
	<b>Serial Number ≥ MY/SG50510001</b>	N9020-20123
W9	<b>Cable Assembly, A10 Output to A11J1 (Semi Rigid)</b>	
	Serial Number < MY/SG50510001	E4410-20159
	<b>Serial Number ≥ MY/SG50510001</b>	N9020-20153
W10	<b>Cable Assembly, J1 to A9 Input (Semi Rigid)</b>	
	Serial Number < MY/SG50510001	E4410-20156
	<b>Serial Number ≥ MY/SG50510001</b>	N9020-20141
W11	<b>Cable Assembly, A9 Output to A10 Input (Semi Rigid)</b>	N9020-20142
W18	<b>Cable Assembly, A11J4 to A15J103 or A15J700 (Ribbon Cable)</b>	E4410-60160
W19	<b>Cable Assembly, A16J701 to A9 Cal Signal Input/Port 2 (Semi Rigid)</b>	
	Serial Number < MY/SG/US52330000	N9020-20157
	<b>Serial Number ≥ MY/SG/US52330000</b>	N9020-20065

Figure 13-10

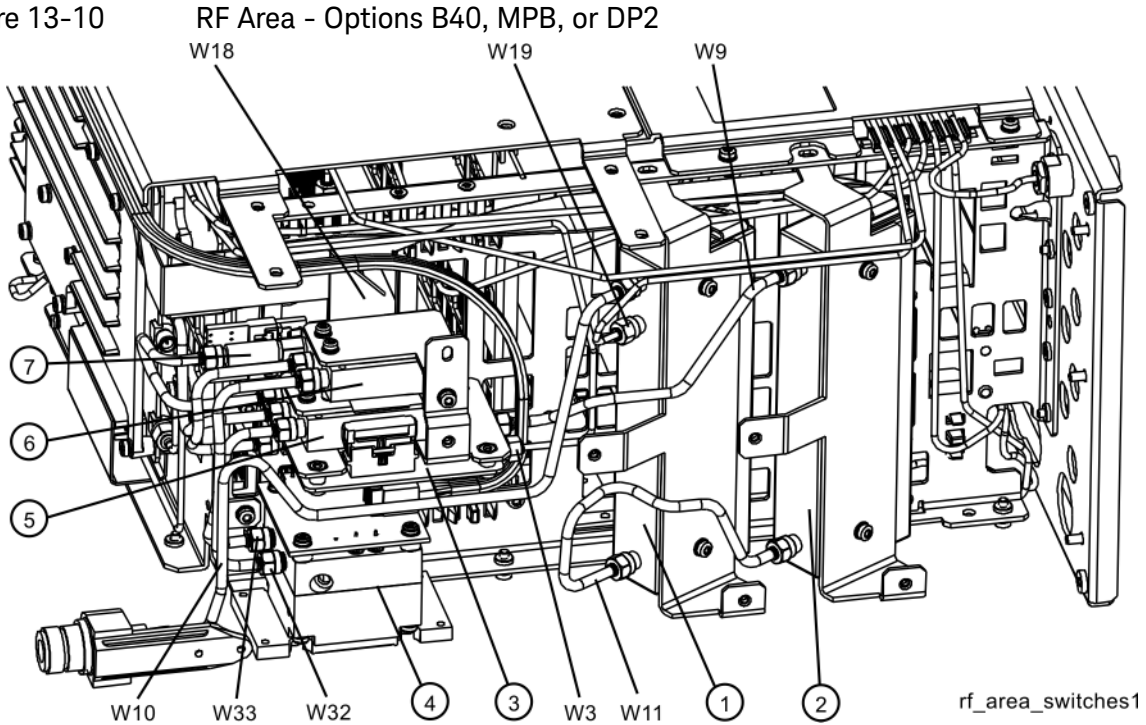


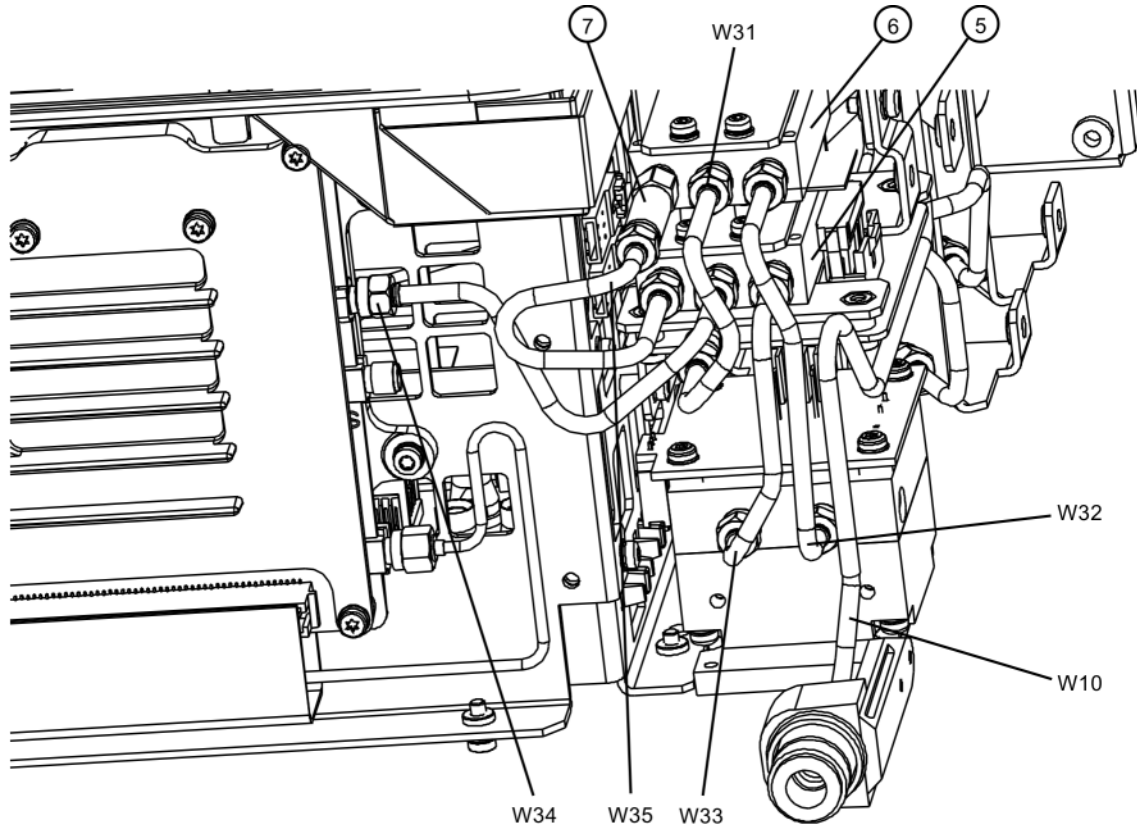
Table 13-12

Item	Description	Keysight Part Number
1	A9 RF Attenuator A (0 to 4 dB)	33360-60008
2	A10 RF Attenuator B (0 to 66 dB)	33321-60083
3	A11 Low Band Switch Assembly	E4410-60121
4	A12 YTF Preselector (except Option 503)	5087-7828
5	SW1 Coaxial Switch (Options B40, MPB, or DP2)	N1810-60069
6	SW2 Coaxial Switch (Options B40, MPB, or DP2)	N1810-60069
7	AT1 Fixed Attenuator, 6 dB	08493-60026
W3	Cable Assembly, A11J2 to A13J2 (Semi Rigid)	
	Serial Number < MY/SG50510001	E4410-20162
	Serial Number ≥ MY/SG50510001	N9020-20101
W9	Cable Assembly, A10 Output to A11J1 (Semi Rigid)	
	Serial Number < MY/SG50510001	E4410-20159
	Serial Number ≥ MY/SG50510001	N9020-20153

Table 13-12

Item	Description	Keysight Part Number
W10	Cable Assembly, J1 to A9 Input (Semi Rigid)	
	Serial Number < MY/SG50510001	E4410-20156
	Serial Number ≥ MY/SG50510001	N9020-20141
W11	Cable Assembly, A9 Output to A10 Input (Semi Rigid)	N9020-20142
W18	Cable Assembly, A11J4 to A15J103 or A15J700 (Ribbon Cable)	E4410-60160
W19	Cable Assembly, A16J701 to A9 Cal Signal Input/Port 2 (Semi Rigid)	
	Serial Number < MY/SG/US52330000	N9020-20157
	Serial Number ≥ MY/SG/US52330000	N9020-20065
W32	Cable Assembly, SW2 Port 2 to A12J2 (Semi-rigid)	E4410-20163
W33	Cable Assembly, SW1 Port 2 to A12J1 (Semi-rigid)	E4410-20165

Figure 13-11 RF Area - Options B40, MPB, or DP2 (switch detail)



rf\_area\_switches2

Table 13-13

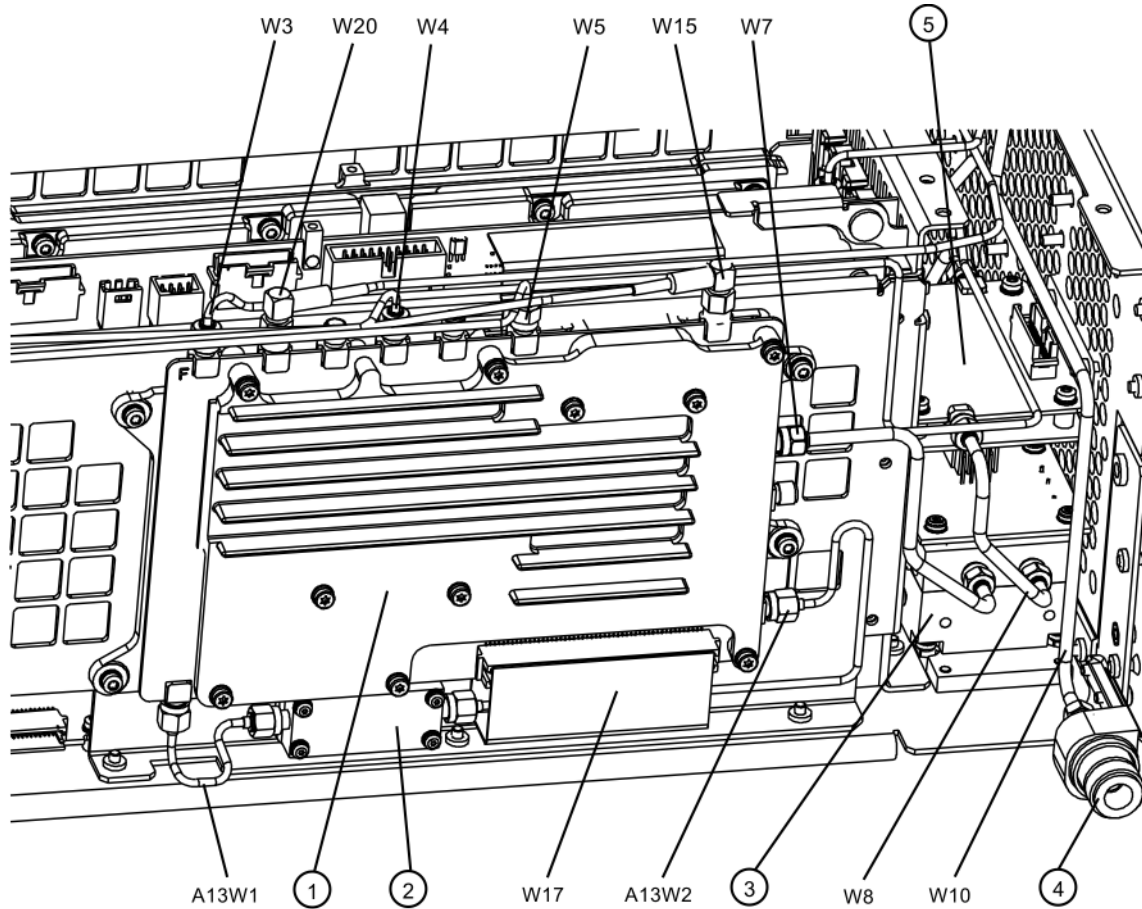
Item	Description	Keysight Part Number
5	SW1 Coaxial Switch (Options B40, MPB, or DP2)	N1810-60069
6	SW2 Coaxial Switch (Options B40, MPB, or DP2)	N1810-60069
7	AT1 Fixed Attenuator, 6 dB	08493-60026
W10	Cable Assembly, J1 to A9 Input (Semi Rigid)	
	Serial Number < MY/SG50510001	E4410-20156
	Serial Number ≥ MY/SG50510001	N9020-20141
W31	Cable Assembly, SW2 Center Port to A11J3 (Semi-rigid)	E4410-20161
W32	Cable Assembly, SW2 Port 2 to A12J2 (Semi-rigid)	E4410-20163
W33	Cable Assembly, SW1 Port 2 to A12J1 (Semi-rigid)	E4410-20165
W34	Cable Assembly, SW1 Center Port to A13J9 (Semi-rigid)	E4410-20164

Replaceable Parts  
Hardware

Table 13-13

Item	Description	Keysight Part Number
W35	Cable Assembly, AT1 to SW1 Port 1 (Semi-rigid)	N9020-20210

Figure 13-12 Front End Parts - Standard Instruments



front\_end\_parts  
Table 13-14

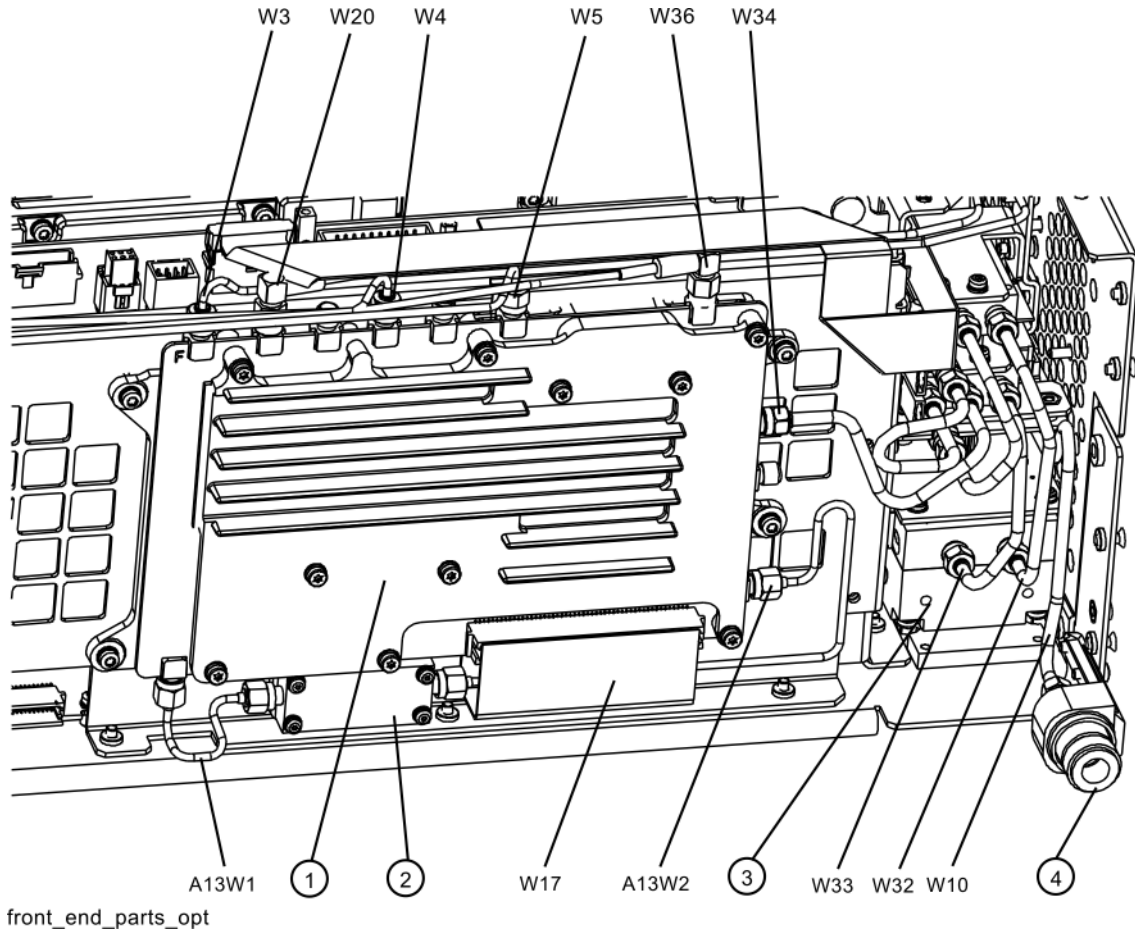
Item	Description	Keysight Part Number
1	A13 RF Front End Assembly	Refer to Table 13-1
2	A13A1 Bandpass Filter	Refer to Table 13-1
A13W1	Cable Assembly, A13J10 to A13A1 Input (Semi Rigid)	Refer to Table 13-1
A13W2	Cable Assembly, A13J11 from A13A1 Output (Semi Rigid)	Refer to Table 13-1
3	A12 YTF Preselector (except Option 503)	5087-7828
4	J1 Type-N (f) RF Input Connector Assembly	5002-0702
5	A11 Low Band Switch Assembly	
W3	Cable Assembly, A11J2 to A13J2 (Semi Rigid)	
	Serial Number < MY/SG50510001	E4410-20162
	Serial Number ≥ MY/SG50510001	N9020-20101

Replaceable Parts  
Hardware

Table 13-14

Item	Description	Keysight Part Number
W4	Cable Assembly, A14J740 to A13J4 (Semi Rigid)	N9020-20156
W5	Cable Assembly, A16J702 to A13J1 (Semi Rigid)	
	Serial Number < MY/SG/US52330000	N9020-20155
	Serial Number ≥ MY/SG/US52330000	N9020-20064
W7	Cable Assembly, A12 Output to A13J9 (Semi Rigid)	N9020-20124
W8	Cable Assembly, A11J3 to A12 Input (Semi Rigid)	
	Serial Number < MY/SG50510001	E4410-20160
	Serial Number ≥ MY/SG50510001	N9020-20123
W10	Cable Assembly, J1 to A9 Input (Semi Rigid)	
	Serial Number < MY/SG50510001	E4410-20156
	Serial Number ≥ MY/SG50510001	N9020-20141
W15	Cable Assembly, A13J7 to A2J100 (Flexible Coax)	8121-1400
W17	Cable Assembly, A13J12 to A15J104 (Ribbon Cable)	E4410-60156
W20	Cable Assembly, A13J6 to A16J705 (Flexible Coax)	8121-1400

Figure 13-13 Front End Parts - Options MPB, B40, DP2, CR3, or CRP



front\_end\_parts\_opt  
Table 13-15

Item	Description	Keysight Part Number
1	A13 RF Front End Assembly	Refer to Table 13-1
2	A13A1 Bandpass Filter	Refer to Table 13-1
A13W1	Cable Assembly, A13J10 to A13A1 Input (Semi Rigid)	Refer to Table 13-1
A13W2	Cable Assembly, A13J11 from A13A1 Output (Semi Rigid)	Refer to Table 13-1
3	A12 YTF Preselector (except Option 503)	5087-7828
4	J1 Type-N (f) RF Input Connector Assembly	5002-0702
5	A11 Low Band Switch Assembly	
W3	Cable Assembly, A11J2 to A13J2 (Semi Rigid)	
	Serial Number < MY/SG50510001	E4410-20162
	Serial Number ≥ MY/SG50510001	N9020-20101



Replaceable Parts  
Hardware

Table 13-15

Item	Description	Keysight Part Number
W4	Cable Assembly, A14J740 to A13J4 (Semi Rigid)	N9020-20156
W5	Cable Assembly, A16J702 to A13J1 (Semi Rigid)	
	Serial Number < MY/SG/US52330000	N9020-20155
	Serial Number ≥ MY/SG/US52330000	N9020-20064
W10	Cable Assembly, J1 to A9 Input (Semi Rigid)	
	Serial Number < MY/SG50510001	E4410-20156
	Serial Number ≥ MY/SG50510001	N9020-20141
W17	Cable Assembly, A13J12 to A15J104 (Ribbon Cable)	E4410-60156
W20	Cable Assembly, A13J6 to A16J705 (Flexible Coax)	8121-1400
W32	Cable Assembly, SW2 Port 2 to A12J2 (Semi-rigid)	E4410-20163
W33	Cable Assembly, SW1 Port 2 to A12J1 (Semi-rigid)	E4410-20165
W34	Cable Assembly, SW1 Center Port to A13J9 (Semi-rigid)	E4410-20164
W36	Cable Assembly, A15J902 to A13J7 (Flexible Coax)	8121-1862

Figure 13-14 Front End Control Cables - early serial numbers

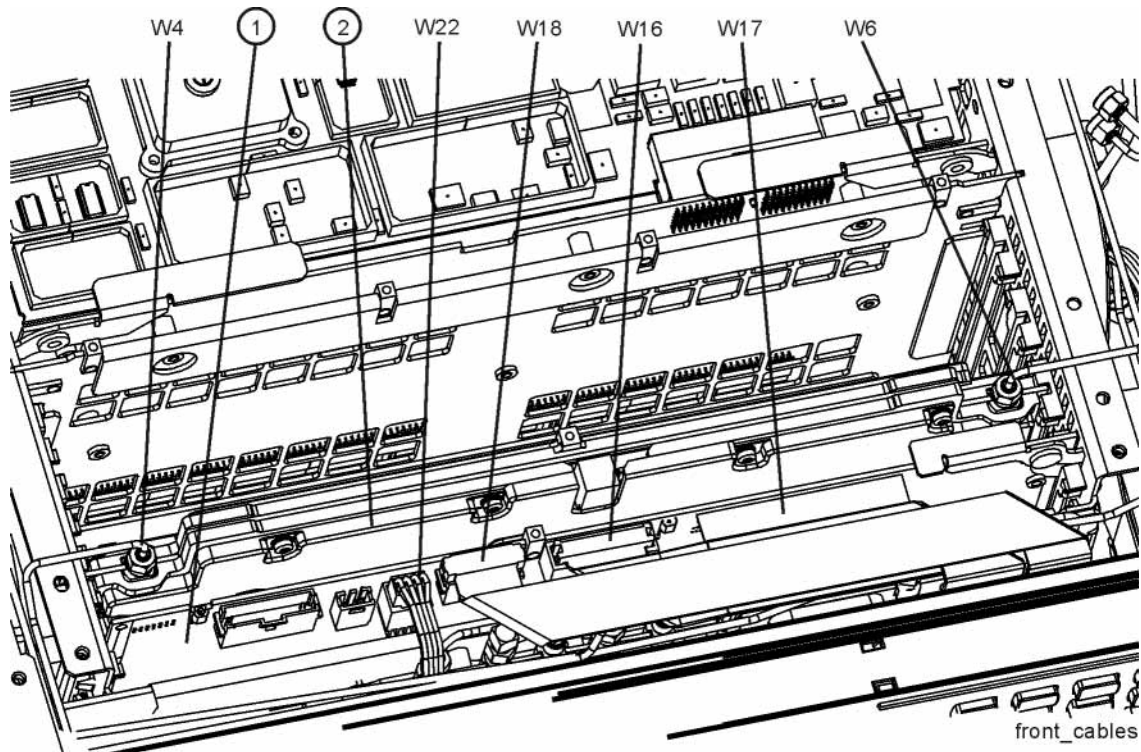


Figure 13-15 Front End Control Cables - later serial numbers

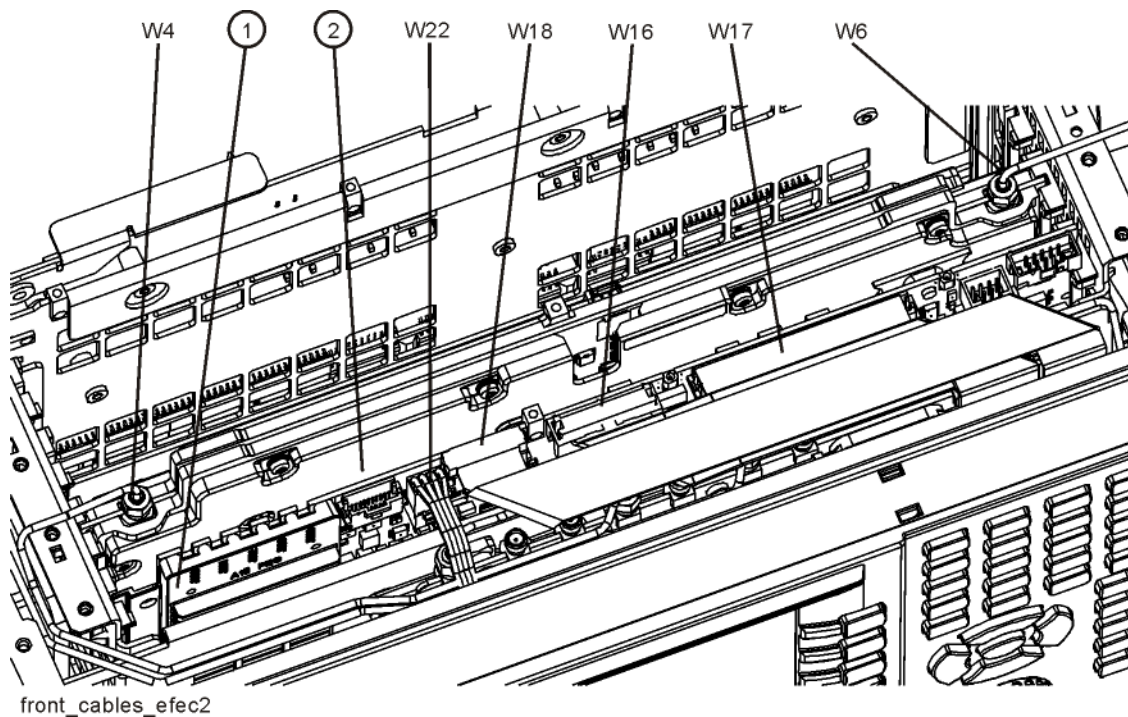
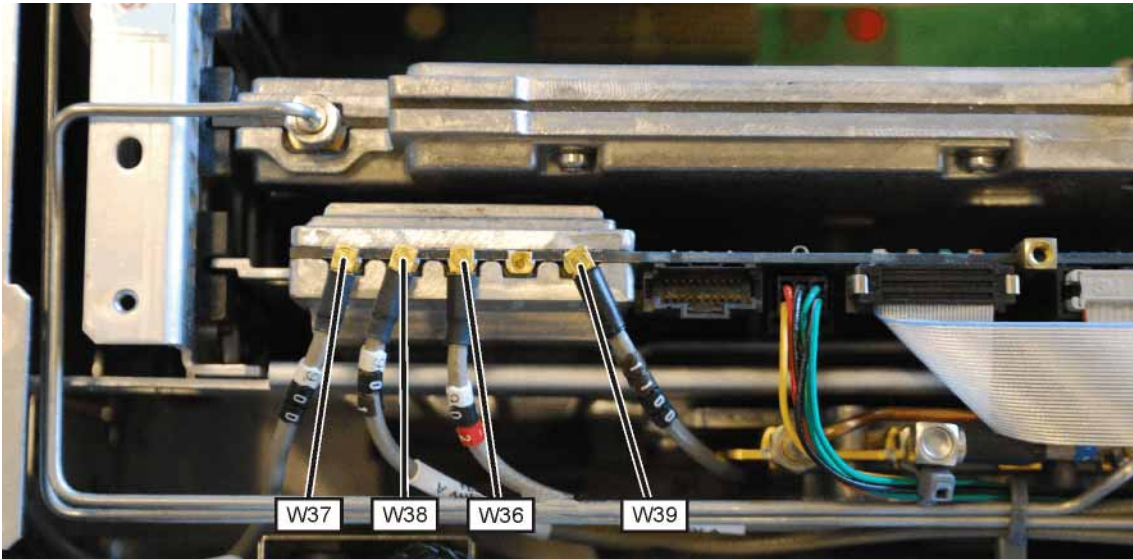


Table 13-16

Item	Description	Keysight Part Number
1	A15 Front End Control Assembly	
	Standard Instruments, Serial Number $\geq$ MY51240512 or $\geq$ SG51240029	N9020-60098
	Standard Instruments, Serial Number $<$ MY51240512 or $<$ SG51240029	N9020-60127
	Options B40, MPB, DP2, CR3, CRP	N9020-60172
2	A14 L.O. Synthesizer Assembly	
	Serial Number $<$ MY/SG/US52330000	E4410-60187
	Serial Number $\geq$ MY/SG/US52330000 except Option HP2	N9020-60118
	Option HP2	E4410-60187
W4	Cable Assembly, A14J740 to A13J4 (Semi Rigid)	N9020-20156
W6	Cable Assembly, A16J703 to A14J200 (Semi Rigid)	
	Serial Number $<$ MY/SG/US52330000	N9020-20154
	Serial Number $\geq$ MY/SG/US52330000	N9020-20033
W16	Cable Assembly, A9 & A10 to A15J801 or A15J102 (Ribbon Cable)	E4410-60157
W17	Cable Assembly, A13J12 to A15J104 (Ribbon Cable)	E4410-60156
W18	Cable Assembly, A11J4 to A15J103 or A15J700 (Ribbon Cable)	E4410-60160
W22	Cable Assembly, A15J301 or A15J300 to A12J1 (Wire Harness)	
	Standard Instruments, Options 508, 513, 526 with Serial Numbers $<$ MY51240512, $<$ SG51240029, $<$ US51240101	E4410-60158
	Standard Instruments, Options 508, 513, 526 with Serial Numbers $\geq$ MY51240512, $\geq$ SG51240029, $\geq$ US51240101	N9020-60059
	Options B40, MPB, DP2, CR3, or CRP	N9020-60059

Figure 13-16 Front End Control Cables - Options B40, MPB, DP2, CR3, or CRP

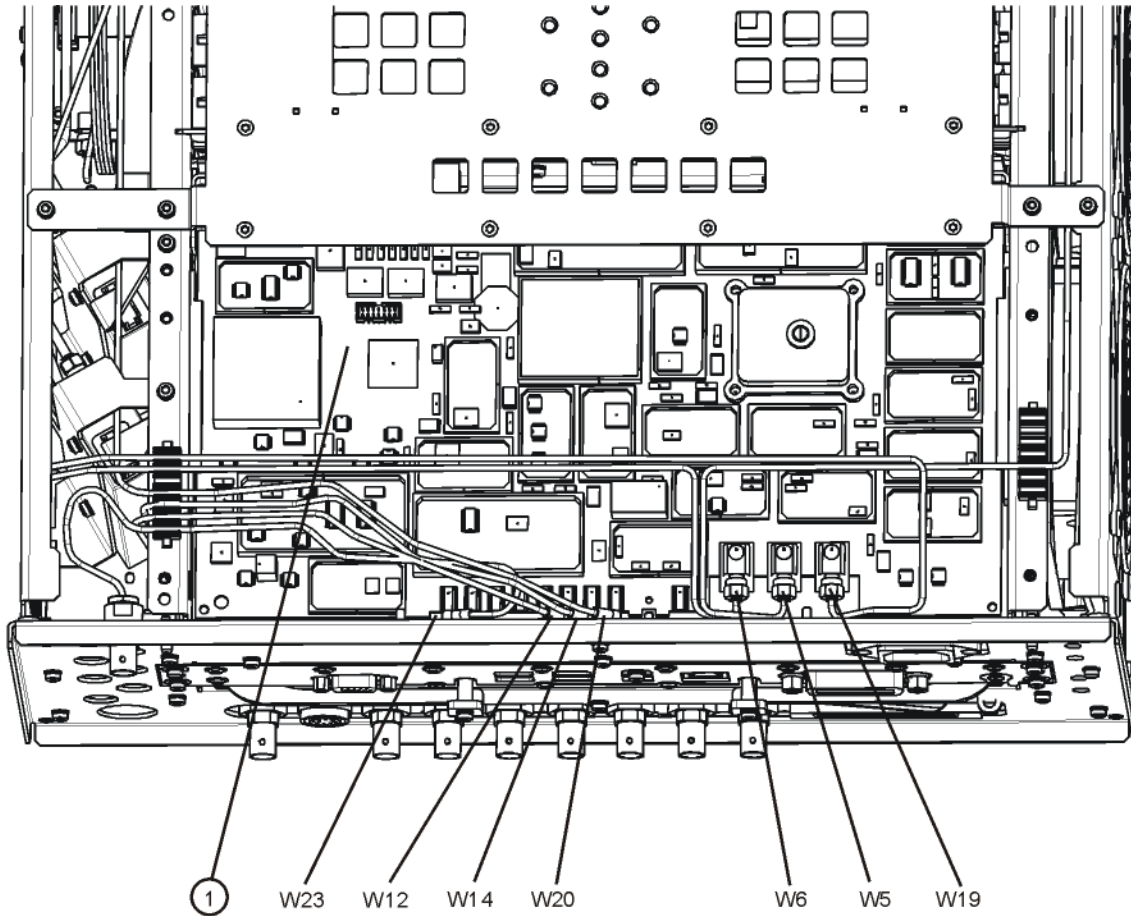


The Front End Control Assembly used in Options MPB, B40, DP2, CR3, and CRP has these additional cables:

Table 13-17

Item	Description	Keysight Part Number
W36	Cable Assembly, A15J902 to A13J7 (Flexible Coax)	8121-1862
W37	Cable Assembly, A15J900 to A2J100 (Flexible Coax)	8121-1401
W38	Cable Assembly, A15J901 to A3J15 (Flexible Coax)	8121-1861
W39	Cable Assembly, A15J1100 to Rear Panel Port 9 (Flexible Coax)	8121-2028

Figure 13-17 Reference Board Cables - Instruments without Option B40, MPB, DP2, B85, B1A, or B1X  
Serial Number < MY/SG/US52330000



reference\_cables  
Table 13-18

Item	Description	Keysight Part Number
1	A16 Reference Assembly	E4410-60108
W5	Cable Assembly, A16J702 to A13J1 (Semi Rigid)	N9020-20155
W6	Cable Assembly, A16J703 to A14J200 (Semi Rigid)	N9020-20154
W12	Cable Assembly, A16J710 to A3J14 (Flexible Coax)	8121-1401
W14	Cable Assembly, A16J711 to A2J300 (Flexible Coax)	8121-1401
W19	Cable Assembly, A16J701 to A9 Cal Signal Input/Port 2 (Semi Rigid)	N9020-20157
W20	Cable Assembly, A13J6 to A16J705 (Flexible Coax)	8121-1400

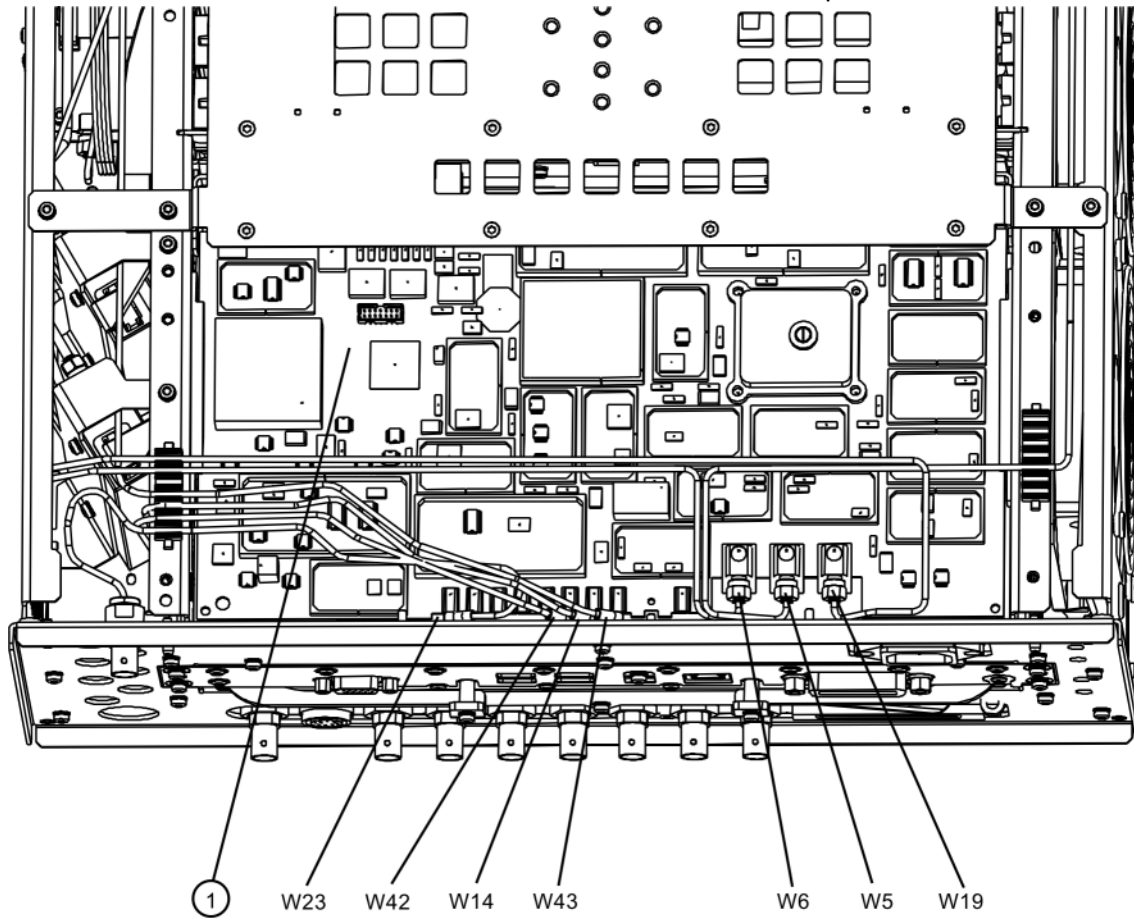
Replaceable Parts  
Hardware

Table 13-18

Item	Description	Keysight Part Number
W23	Cable Assembly, Ext. Reference Cable (rear frame) to A16J704 (Flexible Coax)	8121-1402

Figure 13-18

Reference Board Cables - Options B40, MPB, DP2  
Serial Number < MY/SG/US52330000 without Options B85, B1A, or B1X



reference\_cables\_option  
Table 13-19

Item	Description	Keysight Part Number
1	A16 Reference Assembly	E4410-60108
W5	Cable Assembly, A16J702 to A13J1 (Semi Rigid)	N9020-20155
W6	Cable Assembly, A16J703 to A14J200 (Semi Rigid)	N9020-20154
W14	Cable Assembly, A16J711 to A2J300 (Flexible Coax)	8121-1401
W19	Cable Assembly, A16J701 to A9 Cal Signal Input/Port 2 (Semi Rigid)	N9020-20157
W20	Cable Assembly, A13J6 to A16J705 (Flexible Coax)	8121-1400
W23	Cable Assembly, Ext. Reference Cable (rear frame) to A16J704 (Flexible Coax)	8121-1402
W42	Cable Assembly, A16J706 to A3J14 (Flexible Coax)	8121-1401

Replaceable Parts  
Hardware

Table 13-19

Item	Description	Keysight Part Number
W43	Cable Assembly, A16J705 to A3J18 (Flexible Coax)	8121-1401



Figure 13-19 Reference Board Cables -  
without Options B40, MPB, DP2, B85, B1A, or B1X  
Serial Number  $\geq$  MY/SG/US52330000

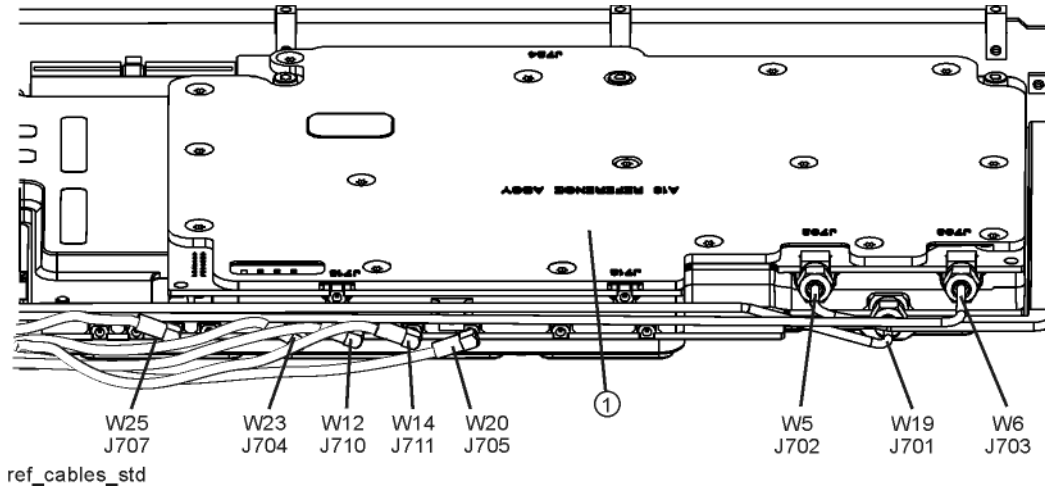
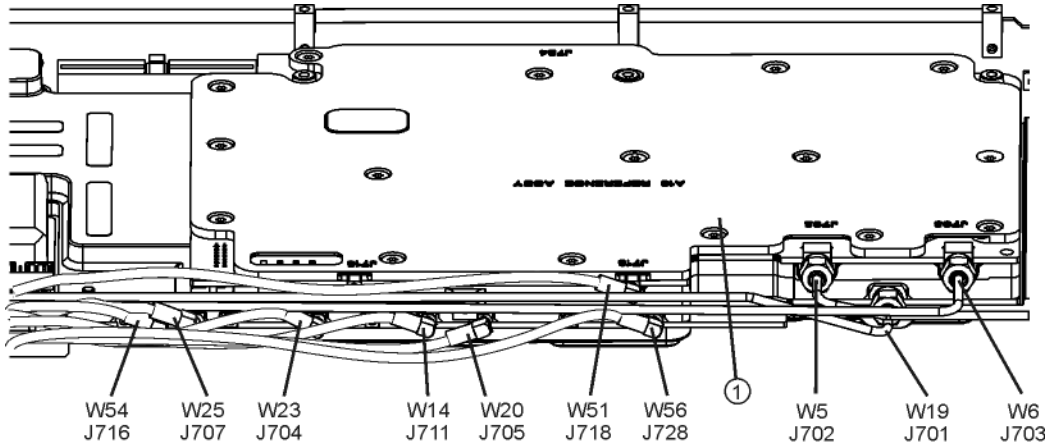


Table 13-20

Item	Description	Keysight Part Number
1	A16 Reference Assembly	N9020-60200
W5	Cable Assembly, A16J702 to A13J1 (Semi Rigid)	N9020-20064
W6	Cable Assembly, A16J703 to A14J200 (Semi Rigid)	N9020-20033
W12	Cable Assembly, A16J710 to A3J14 (Flexible Coax)	8121-1401
W14	Cable Assembly, A16J711 to A2J300 (Flexible Coax)	8121-1401
W19	Cable Assembly, A16J701 to A9 Cal Signal Input/Port 2 (Semi Rigid)	N9020-20065
W20	Cable Assembly, A13J6 to A16J705 (Flexible Coax)	8121-1400
W23	Cable Assembly, Ext. Reference Cable (rear frame) to A16J704 (Flexible Coax)	8121-1402
W25	Cable Assembly A16J707 to A19J101 (Flexible Coax) Option BBA only	8121-1401

Figure 13-20 Reference Board Cables -  
Serial Number < MY/SG/US52330000 with Options B85, B1A, or B1X  
Serial Number ≥ MY/SG/US52330000 with Options B40, MPB, DP2, B85,  
B1A, or B1X



ref\_cables\_opt

Table 13-21

Item	Description	Keysight Part Number
1	A16 Reference Assembly	N9020-60200
W5	Cable Assembly, A16J702 to A13J1 (Semi Rigid)	N9020-20064
W6	Cable Assembly, A16J703 to A14J200 (Semi Rigid)	N9020-20033
W14	Cable Assembly, A16J711 to A2J300 (Flexible Coax)	8121-1401
W19	Cable Assembly, A16J701 to A9 Cal Signal Input/Port 2 (Semi Rigid)	N9020-20065
W20	Cable Assembly, A13J6 to A16J705 (Flexible Coax)	8121-1400
W23	Cable Assembly, Ext. Reference Cable (rear frame) to A16J704 (Flexible Coax)	8121-1402
W25	Cable Assembly A16J707 to A19J101 (Flexible Coax) Option BBA only	8121-1401
W51	Cable Assembly, A16J718 to A25J301 (Flexible Coax)	8121-1401
W54	Cable Assembly, A16J716 to A3J14 (Flexible Coax)	8121-2288
W56	Cable Assembly, A16J726 to A25J806 (Flexible Coax)	8121-2291

Figure 13-21 AIF/DIF Cables - Standard Instruments

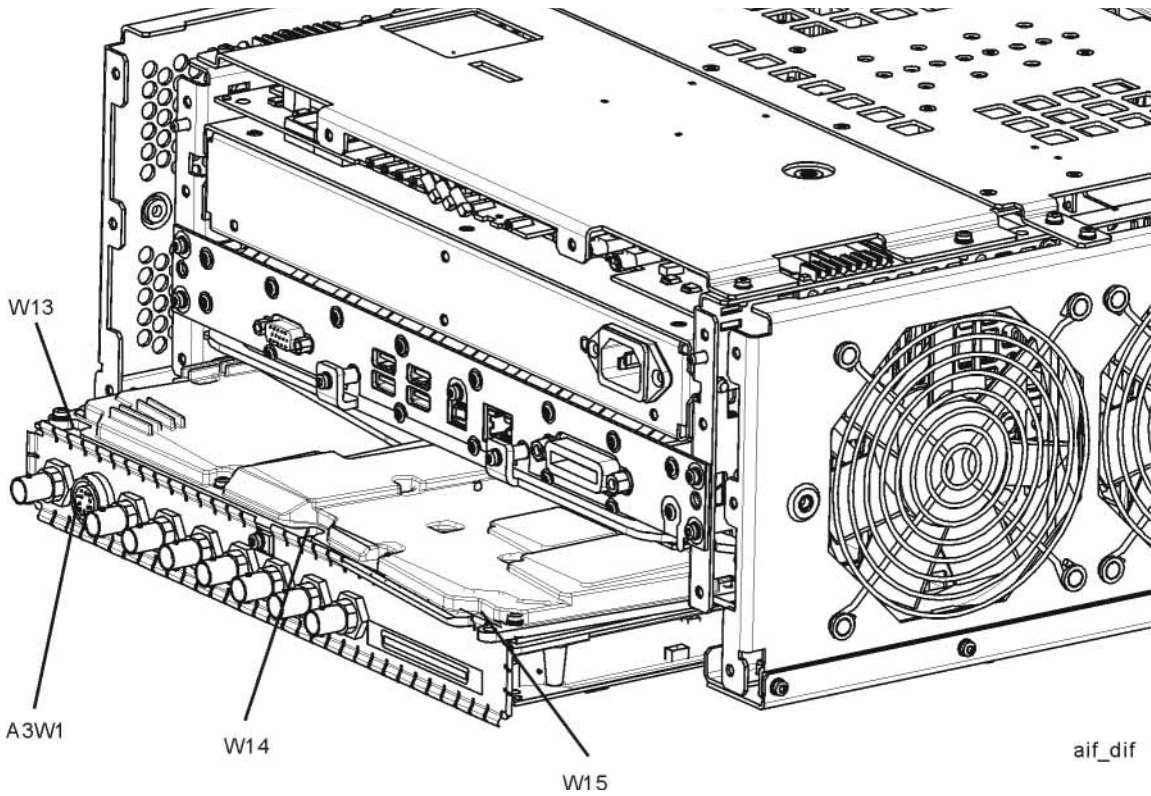


Figure 13-22 AIF/DIF Cables, bottom - Standard Instruments

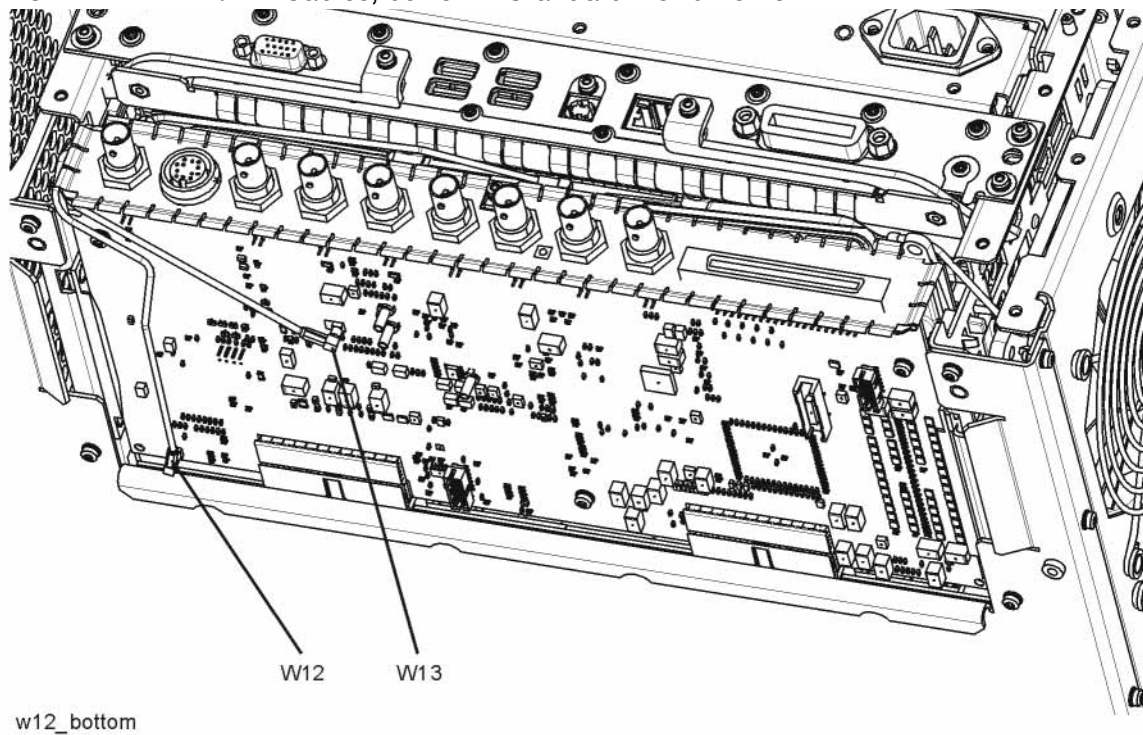


Table 13-22

Item	Description	Keysight Part Number
A3W1	Cable Assembly, Smart Noise Source (Wire Harness)	
	Standard Instruments	E4410-60163
	Options B40, MPB, or DP2	N9020-60090
W12	Cable Assembly, A16J710 to A3J14 (Flexible Coax)	8121-1401
W13	Cable Assembly, A2J601 to A3J15 (Flexible Coax)	8121-1411
W14	Cable Assembly, A16J711 to A2J300 (Flexible Coax)	8121-1401
W15	Cable Assembly, A13J7 to A2J100 (Flexible Coax)	8121-1400

Figure 13-23 AIF/DIF Cables - Options MPB, B40, or DP2

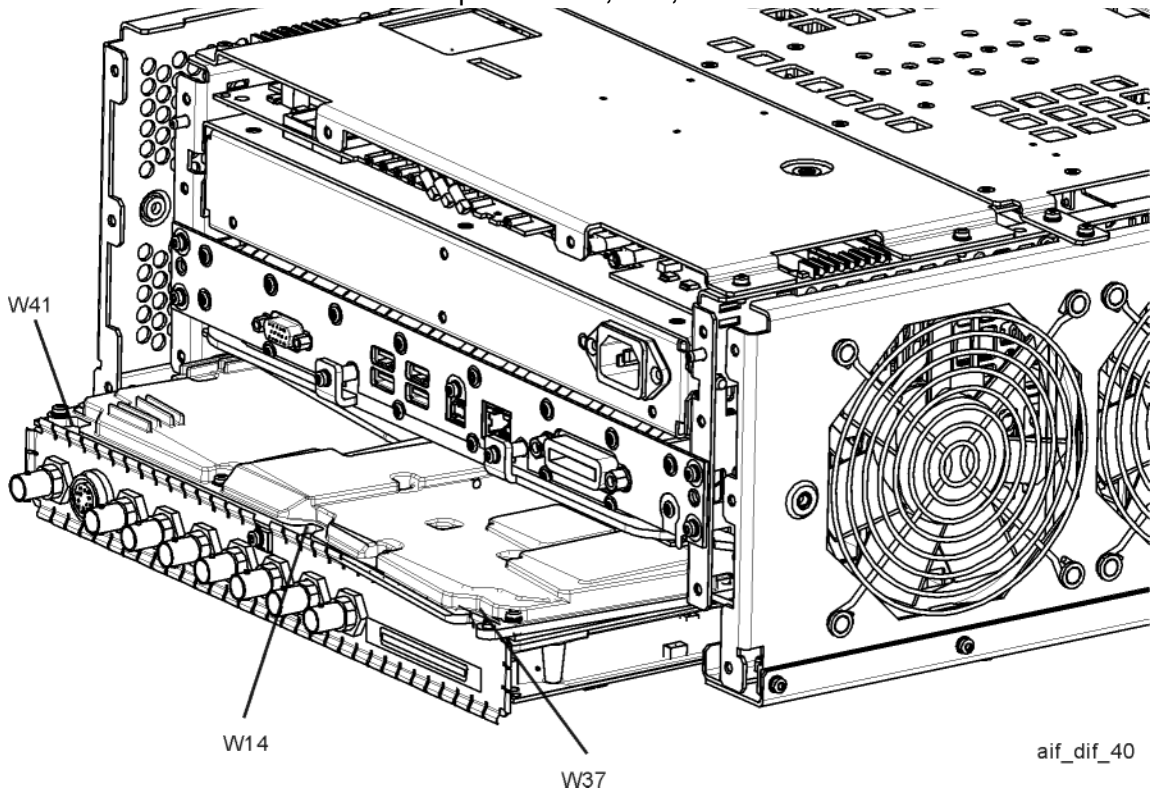


Figure 13-24 AIF/DIF Cables, bottom - Options MPB, B40, or DP2

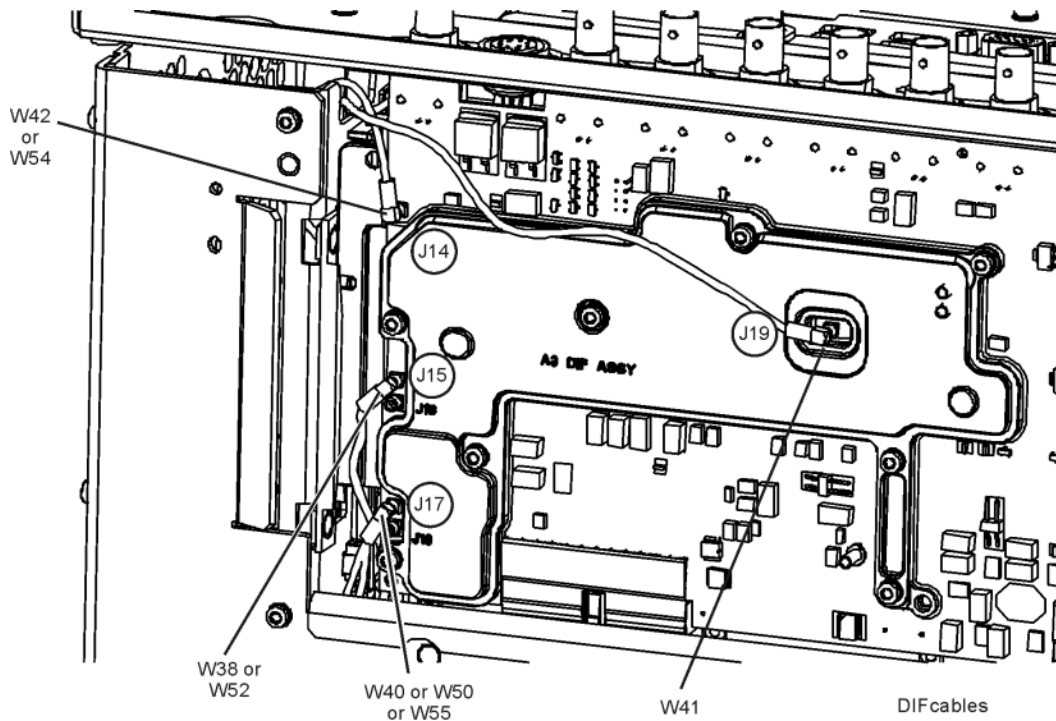
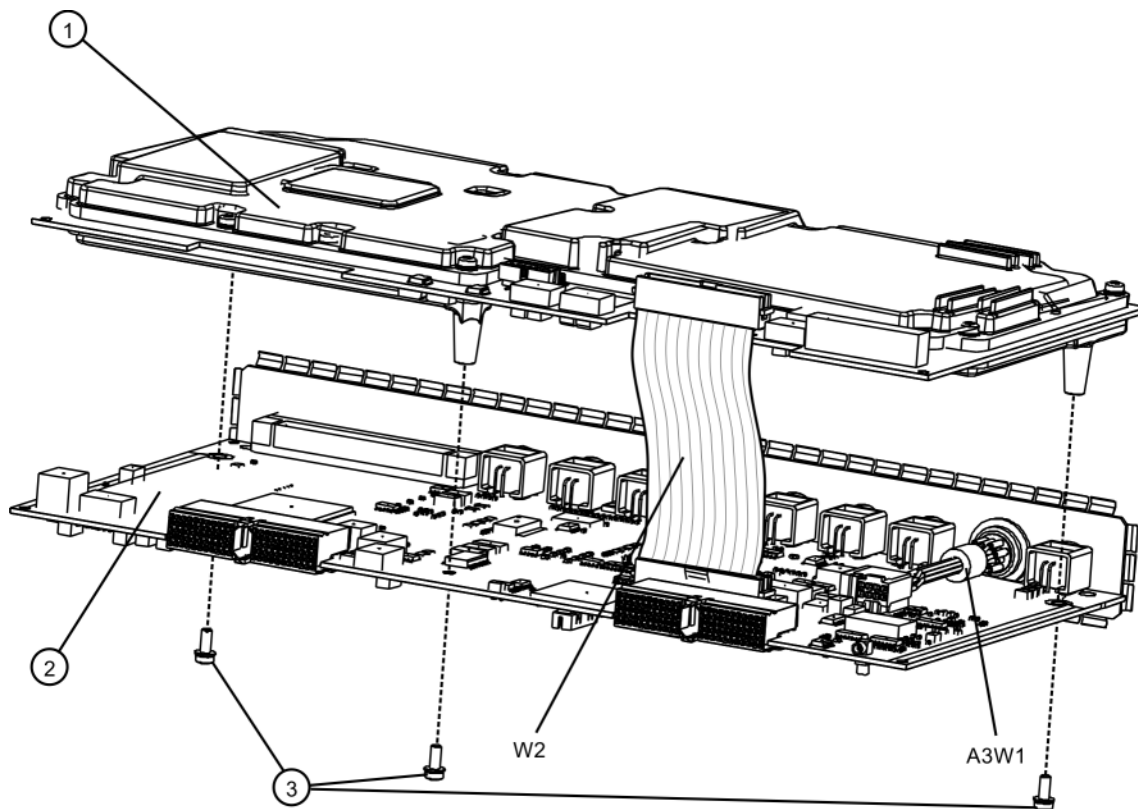


Table 13-23

Item	Description	Keysight Part Number
W14	Cable Assembly, A16J711 to A2J300 (Flexible Coax)	8121-1401
W37	Cable Assembly, A15J900 to A2J100 (Flexible Coax)	8121-1401
W38	Cable Assembly, A15J901 to A3J15 (Flexible Coax)	8121-1861
W40	Cable Assembly, A13J6 to A3J17 (Flexible Coax)	8121-1940
W41	Cable Assembly, A2J601 to A3J19 (Flexible Coax)	8120-8868
W42	Cable Assembly, A16J705 to A3J18 (Flexible Coax)	8121-1401
W50	Cable Assembly, A16J726 to A3J17 (Flexible Coax)	8121-1401
W52	Cable Assembly, A25J102 to A3J15 (Flexible Coax)	8121-2288
W54	Cable Assembly, A16J716 to A3J14 (Flexible Coax)	8121-2288
W55	Cable Assembly, A25J805 to A3J17 (Flexible Coax)	8121-2290

Figure 13-25 AIF/DIF Assemblies - Standard Instruments

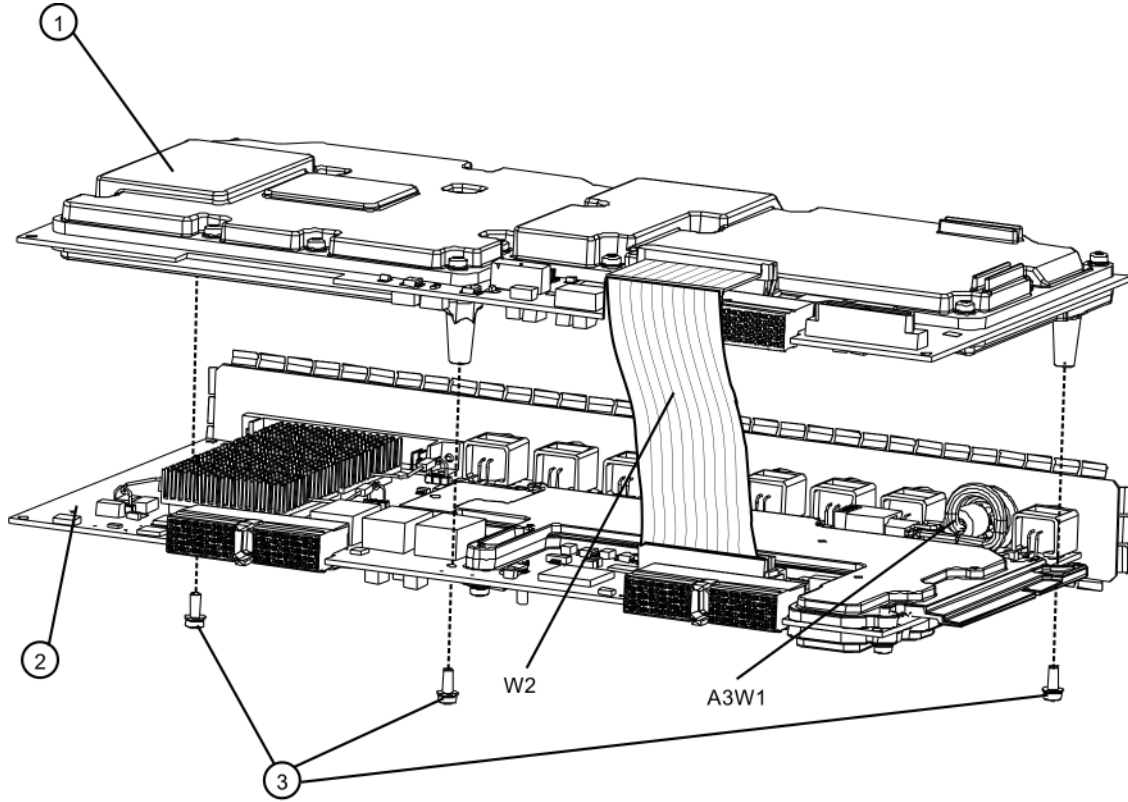


aif\_dif\_separate

Table 13-24

Item	Description	Keysight Part Number
1	A2 Analog I.F. Assembly	
	Standard Instruments, Serial Number < MY/SG/US52330000	E4410-60104
	Standard Instruments, Serial Number ≥ MY/SG/US52330000	N9020-60011
2	A3 Digital I.F. Assembly	N9020-60119
3	Screw, M3 X 0.5 (8 mm long)	0515-0372
W2	Cable, Interconnect from A2J820 to A3J20	E4410-60162
A3W1	Cable Assembly, Smart Noise Source (Wire Harness)	E4410-60163

Figure 13-26 AIF/DIF Assemblies - Option DP2, MPB, B40



aif\_dif\_separate\_b40

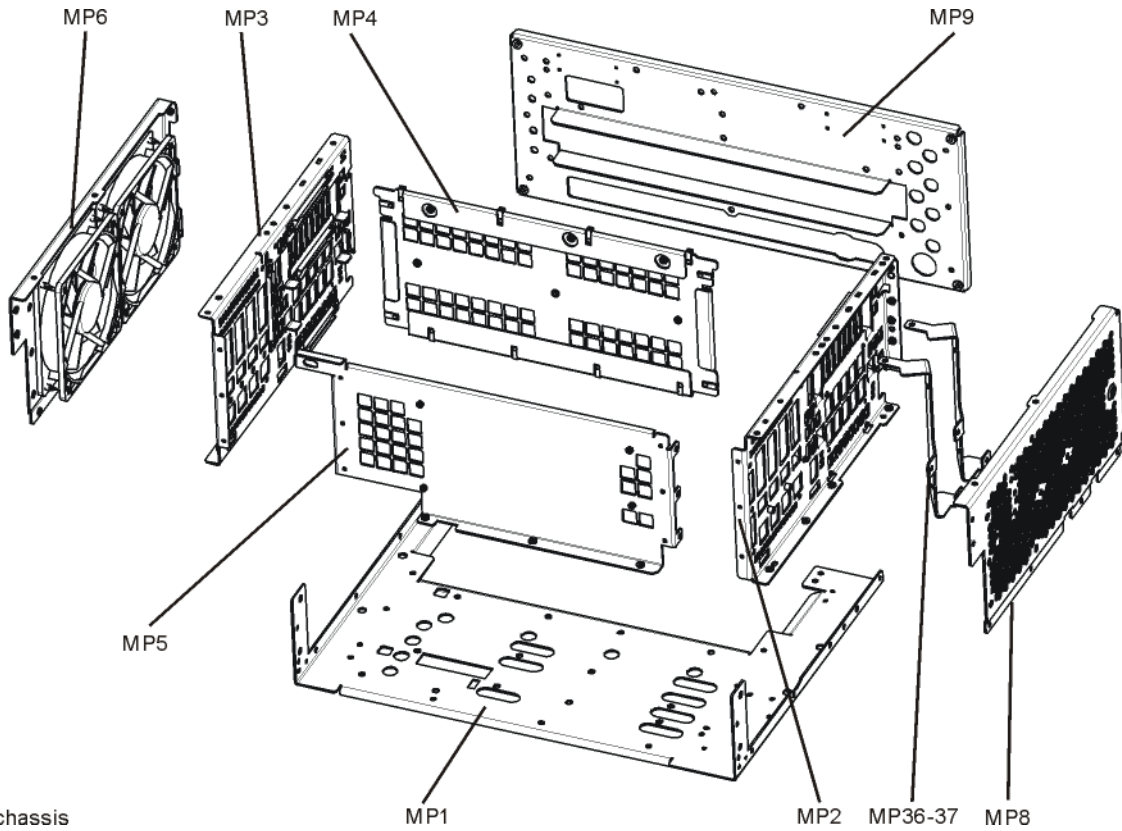
Table 13-25

Item	Description	Keysight Part Number
1	A2 Analog I.F. Assembly	N9020-60011
2	A3 Digital I.F. Assembly	
	Options B40, MPB, or DP2, Serial Number < MY/SG/US52330000 without Option B85, B1A, or B1X	N9020-60165
	Options B40, MPB, or DP2, Serial Number ≥ MY/SG/US52330000 and all with Option B85, B1A, or B1X	N9020-60016
3	Screw, M3 X 0.5 (8 mm long)	0515-0372
W2	Cable, Interconnect from A2J820 to A3J20	N9020-60046
A3W1	Cable Assembly, Smart Noise Source (Wire Harness)	N9020-60090



Figure 13-27

Chassis



chassis  
Table 13-26

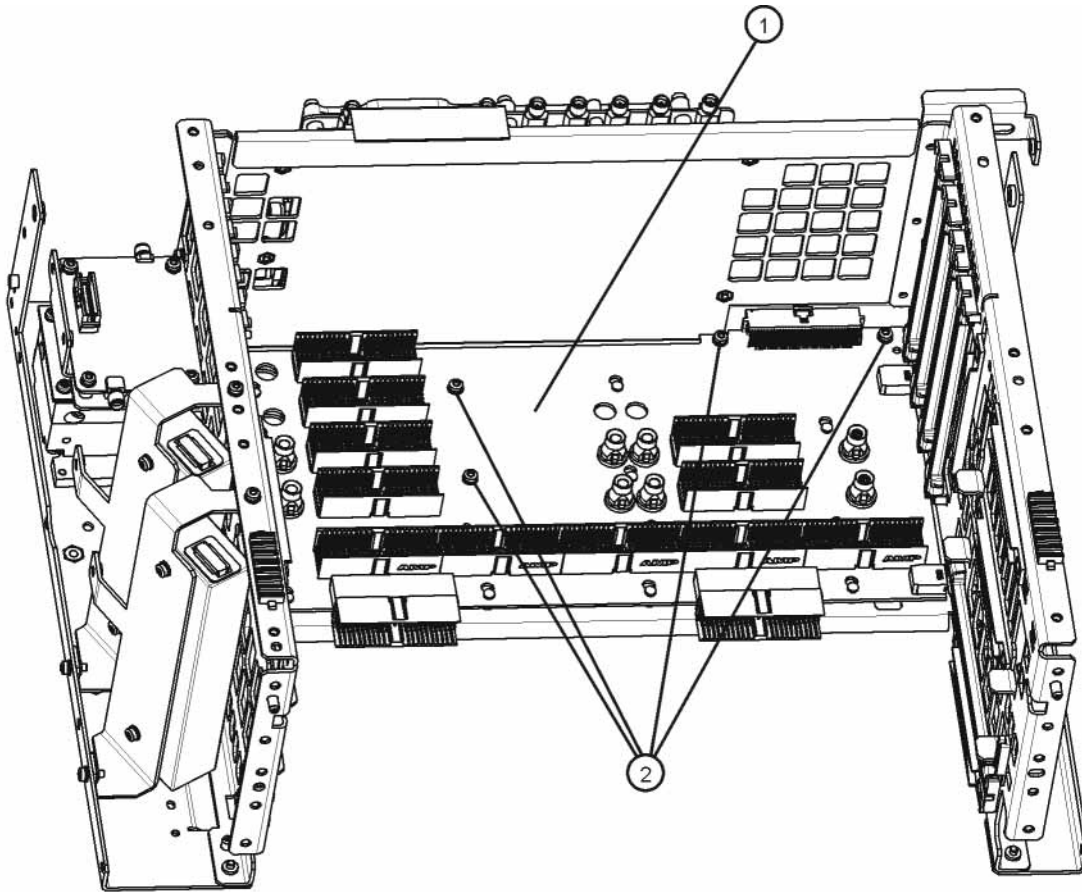
Item	Description	Keysight Part Number Serial Number < MY/SG/US5233	Keysight Part Number Serial Number ≥ MY/SG/US5233
		MP1	Chassis Base
MP2	Chassis Side, Right (inner)	W1312-00046	W1312-00135
MP3	Chassis Side, Left (inner)	W1312-00047	W1312-00136
MP4	Midplane Bracket	W1312-00048	
MP5	Chassis Front Bracket	W1312-00049	W1312-00098
MP6	Fan Bracket	W1312-00133	W1312-00137

Table 13-26

Item	Description	Keysight Part Number Serial Number < MY/SG/US5233	Keysight Part Number Serial Number ≥ MY/SG/US5233
MP8	Chassis Side, Right (Outer, attaches to Low Band Switch bracket, Attenuator brackets, and Chassis bottom)		
	Serial Number < MY/SG/US50510001 <sup>a</sup>	E4410-00101	
	Serial Number ≥ MY/SG/US50510001 to < MY/SG/US52330000	N9020-00031	N9020-00034
MP9	Rear Panel Replacement Kit (includes foam strip)	Refer to Table 13-1	
MP36-37	Attenuator Bracket	N9020-00052	

a. Use N9020-00031 if Option B40, MPB, or DP2 is installed.

Figure 13-28 Motherboard



motherboard\_replace  
Table 13-27

Item	Description	Keysight Part Number
1	A8	N9000-66404
2	Screw M3 X0.5 (8 mm long)	0515-0372

Figure 13-29 Fan Hardware

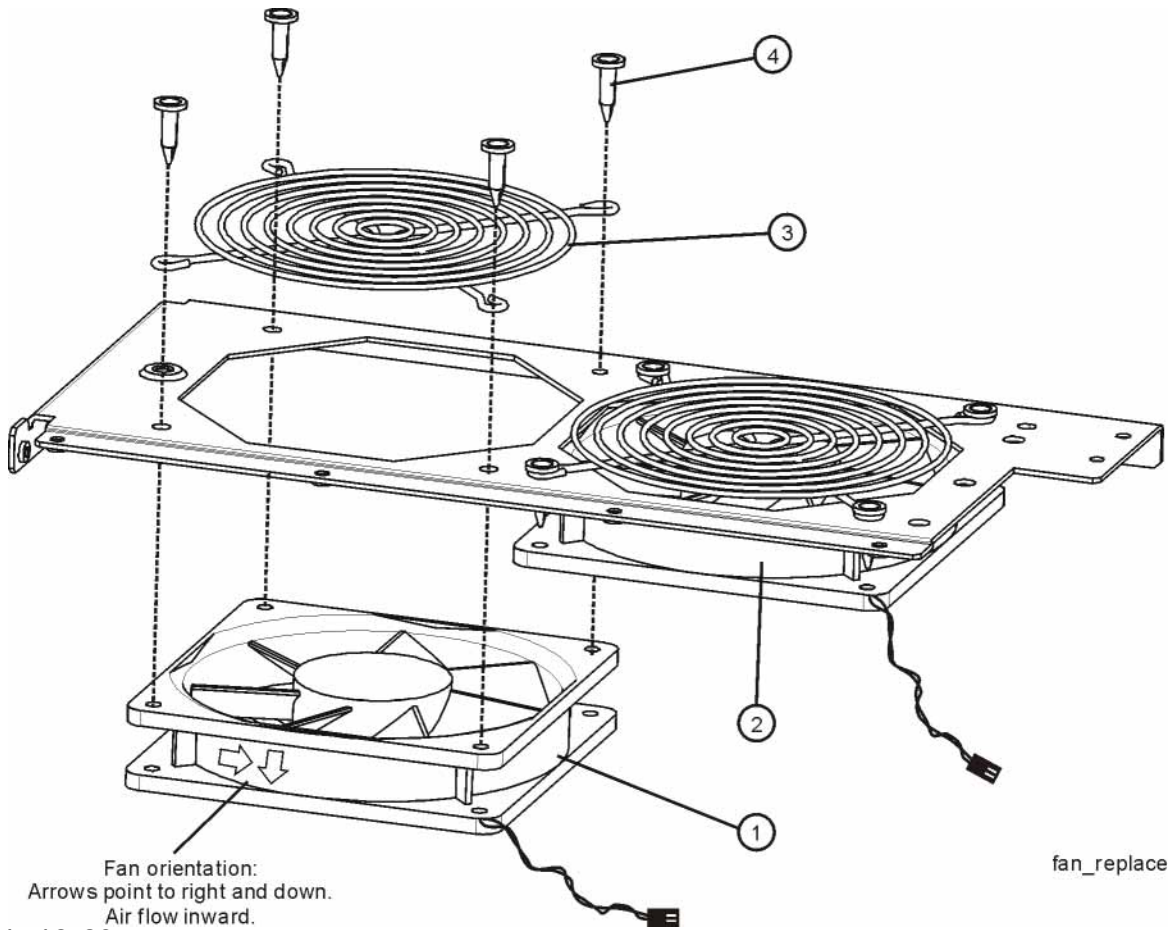
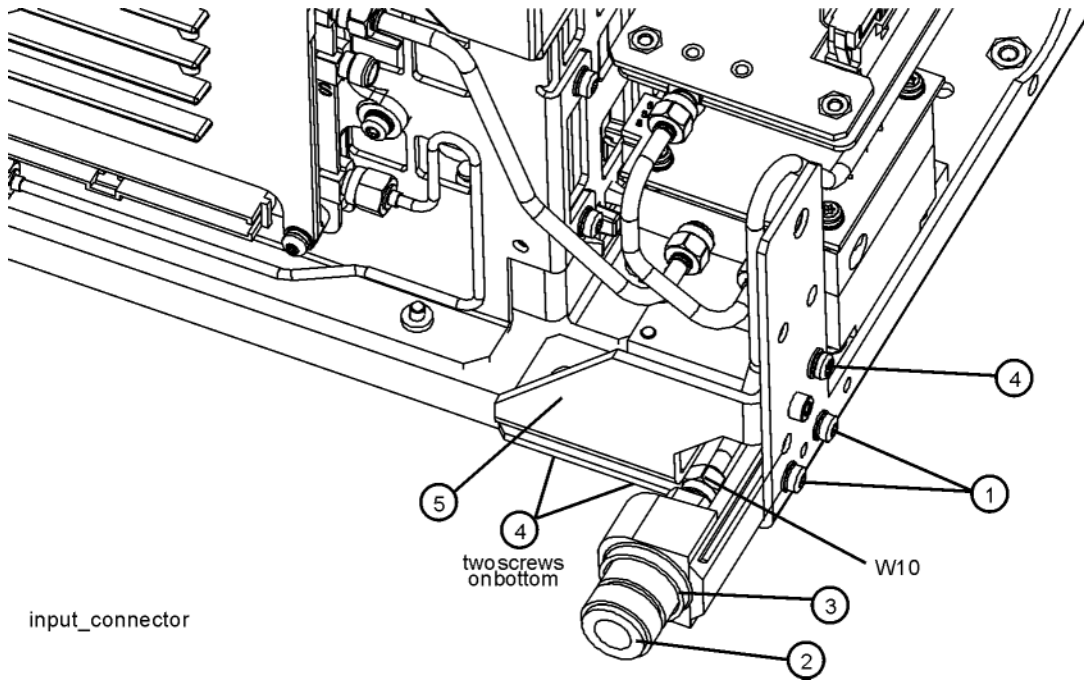


Table 13-28

Item	Description	Keysight Part Number
1	B1 Fan	3160-4199
2	B2 Fan	3160-4199
3	MP25-26 Fan Guard	3160-0281
4	MP27-34 Rivet, Fan Mounting (8 pieces)	0361-1272

Figure 13-30 Input Connector



input\_connector

Table 13-29

Item	Description	Keysight Part Number
1	Screw M3 X 0.5 (8 mm long)	0515-0372
2	J1 Type-N (f) RF Input Connector Assembly	5002-0702
3	EMI O-Ring 18.75 mm ID (used between RF Input Connector and Front Frame)	8160-1637
4	Screw M3 X 0.5 (8 mm long)	0515-0372
W10	Cable Assembly, J1 to A9 Input (Semi Rigid)	
	Serial Number < MY/SG50510001 <sup>i</sup>	E4410-20156
	Serial Number ≥ MY/SG50510001	N9020-20141
5	MP83 Gusset, Chassis (near RF Input connector)	W1312-00093

Figure 13-31 Front Frame Parts - LCD

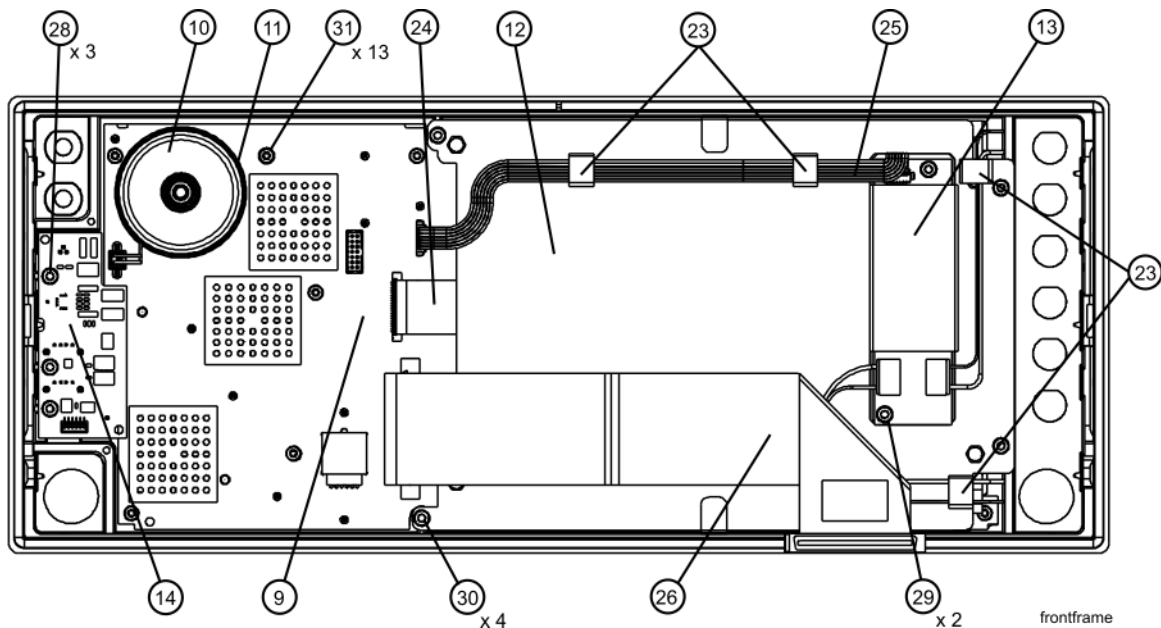


Table 13-30

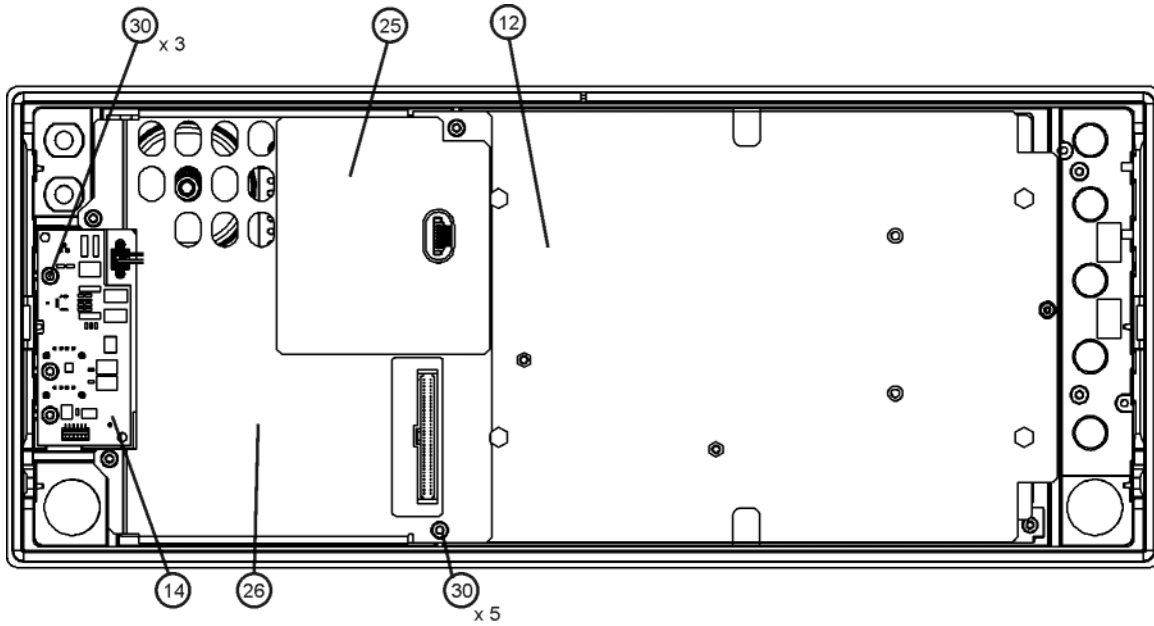
Item	Description	Keysight Part Number
9	A1A2 <b>Front Panel Interface Board</b>	
	<b>Serial Number <math>\geq</math> MY48030101, <math>\geq</math> SG48030001, <math>\geq</math> US48010001 to Serial Number <math>&lt;</math> MY/SG/US51240000</b>	<b>W1312-60042</b>
	<b>Serial Number <math>&lt;</math> MY48030101, SG48030001, US48010001</b>	<b>N9020-60033</b>
10	<b>A1A2MP1 Speaker</b>	<b>9164-0453</b>
11	<b>A1A2MP2 Speaker Foam</b>	<b>W1312-40016</b>
12	<b>A1A3 Liquid Crystal Display</b>	<b>2090-0911</b>
13	<b>A1A4 Inverter Board (Display Backlight Power) Serial Number <math>&lt;</math> MY/SG/US51240000</b>	<b>0950-4635</b>
14	<b>A1A5 Front Panel Daughter Board</b>	<b>N9020--63193</b>
23	<b>A1MP10-13 Cable Clamp (Front Panel Cables)</b>	<b>1400-2225</b>

Replaceable Parts  
Hardware

Table 13-30

Item	Description	Keysight Part Number
24	A1W1 Flex Circuit, Display to Front Panel Interface Board	W1312-60010
25	A1W2 Power Cable, Front Panel Interface Board to Inverter Board	W1312-60011
26	W1 Cable, Front Panel Interface Board to Motherboard (Ribbon)	
	Serial Number $\geq$ MY/SG48010101, US48010001	N9020-60036
	Serial Number $<$ MY/SG48010101, US48010001	E4410-60171
28, 28, 30	Screw M3 X 0.5 (8 mm long)	0515-0372
31	Screw M3 X 0.5 (5 mm long)	0515-1521

Figure 13-32 Front Frame Parts - LED



frontframe\_LED

Table 13-31

Item	Description	Keysight Part Number
12	A1MP14 Display Bracket	W1312-00145
14	A1A5 Front Panel Daughter Board	N9020--63193
25	A1MP24 Magnetic Shield (Display Bracket to Front Panel Interface/Speaker Bracket)	N9020-00029
26	A1MP23 Front Panel Interface/Speaker Bracket	N9020-00028
30	Screw Front Panel Daughter Board	0515-0372



Figure 13-33 Front Frame Parts (shields off) - LED

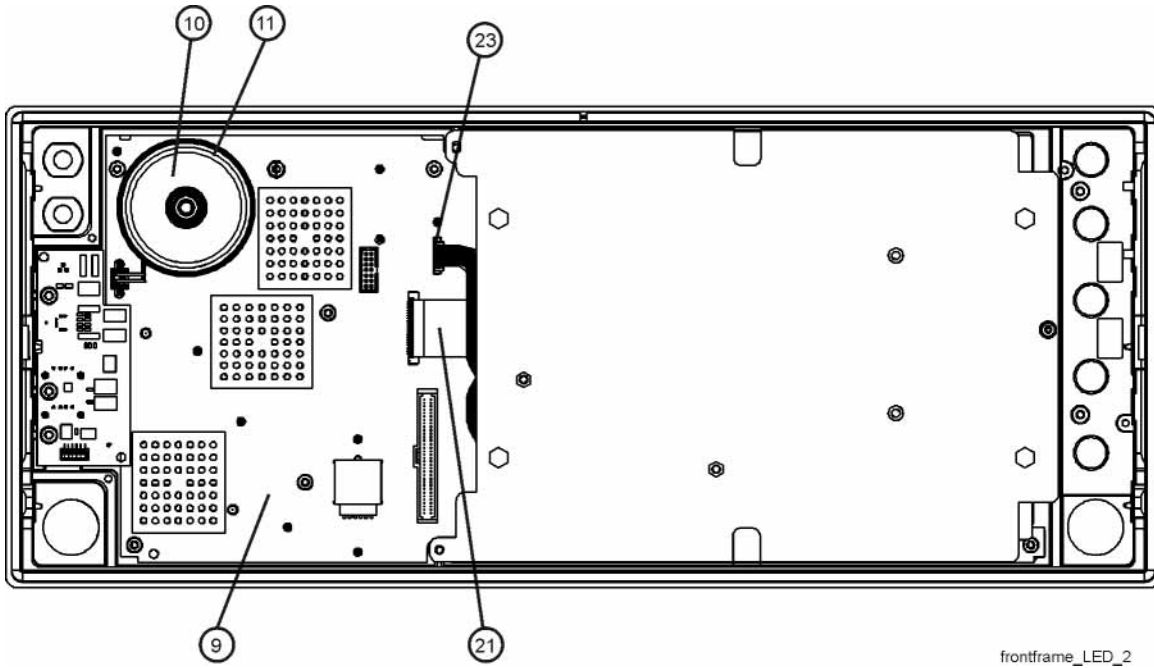


Table 13-32

Item	Description	Keysight Part Number
9	A1A2 Front Panel Interface Board	
	Serial Number $\geq$ MY/SG/US51240000	W1312-60137
	Serial Number $\geq$ MY48030101, $\geq$ SG48030001, $\geq$ US48010001 to Serial Number $<$ MY/SG/US51240000	W1312-60042
	Serial Number $<$ MY48030101, SG48030001, US48010001	N9020-60033
10	A1A2MP1 Speaker	9164-0453
11	Speaker Foam	W1312-40016
21	A1W1 Flex Circuit, Display to Front Panel Interface Board	
	Serial Number $\geq$ MY/SG/US51240000	W1312-60122
	Serial Number $<$ MY/SG/US51240000	W1312-60010
23	A1W2 Power Cable, Front Panel Interface Board to Inverter Board	W1312-60011

Figure 13-34 Front Frame Exploded View - LCD

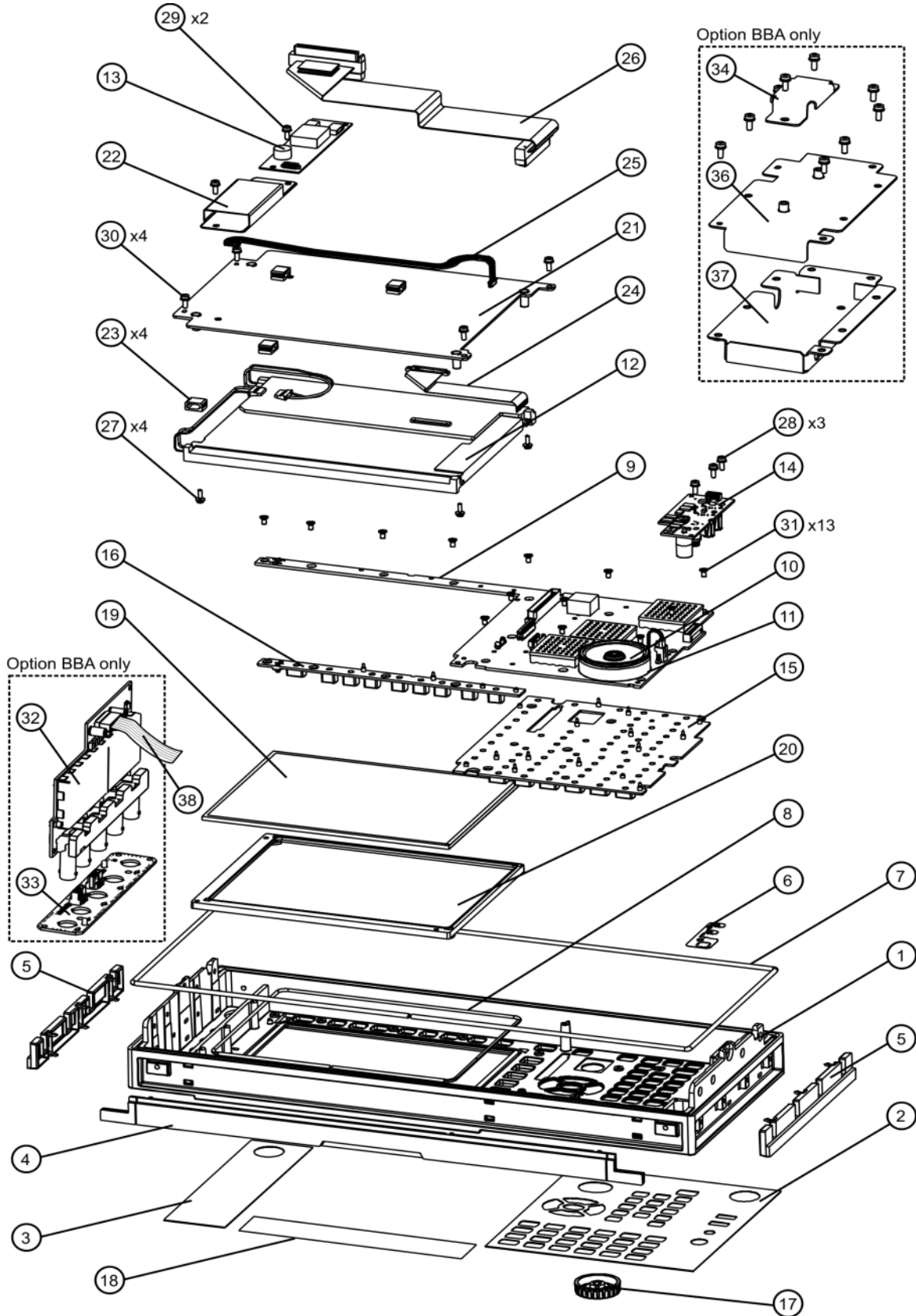


Table 13-33

Item	Description	Keysight Part Number
1	A1A1MP1 Front Frame	W1312-20108 <sup>a</sup>
2	A1A1MP2 Main Keypad Overlay <sup>b</sup>	N9020-60137
3	A1A1MP3 Connector Overlay	E4410-80109
4a	A1A1MP7 Front Frame Top Trim Strip (Use with Option PRC, Portable)	W1312-40004 (Illustrated)
4b	A1A1MP8 Front Frame Top Trim Strip (Use with standard Bench analyzer)	W1312-40019 (Not Illustrated)
5	A1A1MP9-10 Front Frame Side Trim Strip	W1312-40005
6	A1A1MP4 Front Frame Ground Spring	W1312-00021
7	A1A1MP5 Braided Gasket	--
8	A1A1MP6 Chromeric Gasket	--
9	A1A2 Front Panel Interface Board	
	Serial Number $\geq$ MY/SG/US51240000	W1312-60137
	Serial Number $\geq$ MY48030101, $\geq$ SG48030001, $\geq$ US48010001 to Serial Number $<$ MY/SG/US51240000	W1312-60042
	Serial Number $<$ MY48030101, SG48030001, US48010001	N9020-60033
10	A1A2MP1 Speaker	9164-0453
11	A1A2MP2 Speaker Foam	W1312-40016
12	A1A3 Liquid Crystal Display	
	Serial Number $\geq$ MY/SG51240000	2090-0997
	Serial Number $<$ MY/SG51240000	2090-0911
13	A1A4 Inverter Board (Display Backlight Power) Serial Number $<$ MY/SG/US51240000	0950-4635
14	A1A5 Front Panel Daughter Board	N9020--63193
15	A1MP1 Main Keypad	E4410-40100
16	A1MP2 Display Keypad	E4410-40101
17	A1MP9 Knob	W1312-40017

Table 13-33

Item	Description	Keysight Part Number
18	A1MP3 Frequency Label, 3.6 GHz A1MP4 Frequency Label, 8.4 GHz A1MP5 Frequency Label, 13.6 GHz A1MP6 Frequency Label, 26.5 GHz	Refer to Table 13-1
19	A1MP7 LCD Glass Filter	1000-1513
20	A1MP8 LCD Lens Gasket	W1312-40006
21	A1MP14 Display Bracket	
	Serial Number $\geq$ MY/SG/US51240000	W1312-00145
	Serial Number $<$ MY/SG/US51240000	W1312-00023
22	A1MP15 Inverter Board Shield	W1312-00024
23	A1MP10-13 Cable Clamp (Front Panel Cables)	1400-2225
24	A1W1 Flex Circuit, Display to Front Panel Interface Board	
	Serial Number $\geq$ MY/SG/US51240000	W1312-60122
	Serial Number $<$ MY/SG/US51240000	W1312-60010
25	A1W2 Power Cable, Front Panel Interface Board to Inverter Board	W1312-60011
26	W1 Cable, Front Panel Interface Board to Motherboard (Ribbon)	
	Serial Number $\geq$ MY/SG48010101, US48010001	N9020-60036
	Serial Number $<$ MY/SG48010101, US48010001	E4410-60171
27	Screw M3 X 0.5 (8 mm long)	0515-0372
28, 29, 30	Screw M3 X 0.5 (8 mm long)	0515-0372
31	Screw M3 X 0.5 (5 mm long)	0515-1521
32	A18 BBIQ Interface Board (Option BBA)	N9020-60094
33	A17 BBIQ LED Board (Option BBA)	N9020-63095
34	A1MP18 Core Bracket (Option BBA)	N9020-00012
36	A1MP16 Inverter Top Shield (Option BBA) Serial Number $<$ MY/SG/US51240000	N9020-00010
37	A1MP17 Inverter Bottom Shield (Option BBA) Serial Number $<$ MY/SG/US51240000	N9020-00011

Replaceable Parts  
Hardware

- a. Non-orderable item, see A1A1.

Figure 13-35 Front Frame Exploded View - LED

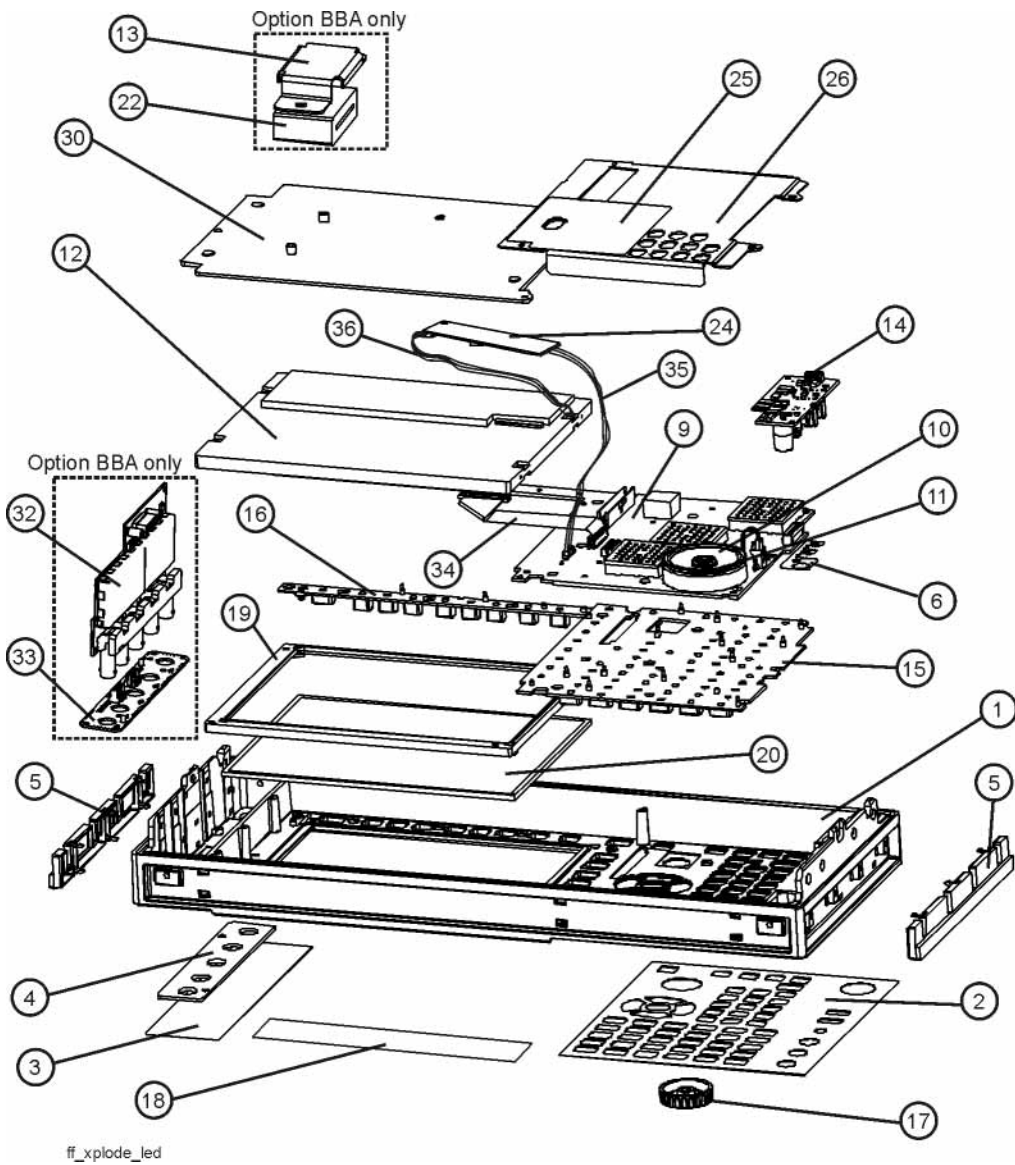


Table 13-34

Item	Description	Keysight Part Number
1	Front Frame	---a
2	A1A1MP2 Main Keypad Overlay <sup>b</sup>	N9020-60137
3	A1A1MP3 Connector Overlay	E4410-80109
4	A1A1MP18 Cover Plate	N9020-00002
5	A1A1MP9-10 Front Frame Side Trim Strip	W1312-40005
6	A1A1MP4 Front Frame Ground Spring	W1312-00021
9	A1A2 Front Panel Interface Board	Refer to Table 13-1
10	A1A2MP1 Speaker	9164-0453
11	A1A2MP2 Speaker Foam	W1312-40016
12	A1A3 Liquid Crystal Display	2090-0997
13	MP76 Vibration Mount (Option BBA Core Bracket)	0460-2725
14	A1A5 Front Panel Daughter Board	N9020--63193
15	A1MP1 Main Keypad	E4410-40100
16	A1MP2 Display Keypad	E4410-40101
17	A1MP9 Knob	W1312-40017
18	A1MP3 Frequency Label, 3.6 GHz A1MP4 Frequency Label, 8.4 GHz A1MP5 Frequency Label, 13.6 GHz A1MP6 Frequency Label, 26.5 GHz	Refer to Table 13-1
19	A1MP8 LCD Lens Gasket	W1312-40006
20	A1MP7 LCD Glass Filter	1000-1513
22	A1MP18 Core Bracket (Option BBA)	N9020-00012
24	A1A4 DC-DC Converter (LED display backlight power)	0950-5235
25	A1MP24 Magnetic Shield (Display Bracket to Front Panel Interface/Speaker Bracket)	N9020-00029
26	A1MP23 Front Panel Interface/Speaker Bracket	N9020-00028
30	A1MP14 Display Bracket	W1312-00145
32	A18 BBIQ Interface Board (Option BBA)	N9020-60094
33	A17 BBIQ LED Board (Option BBA)	N9020-63095

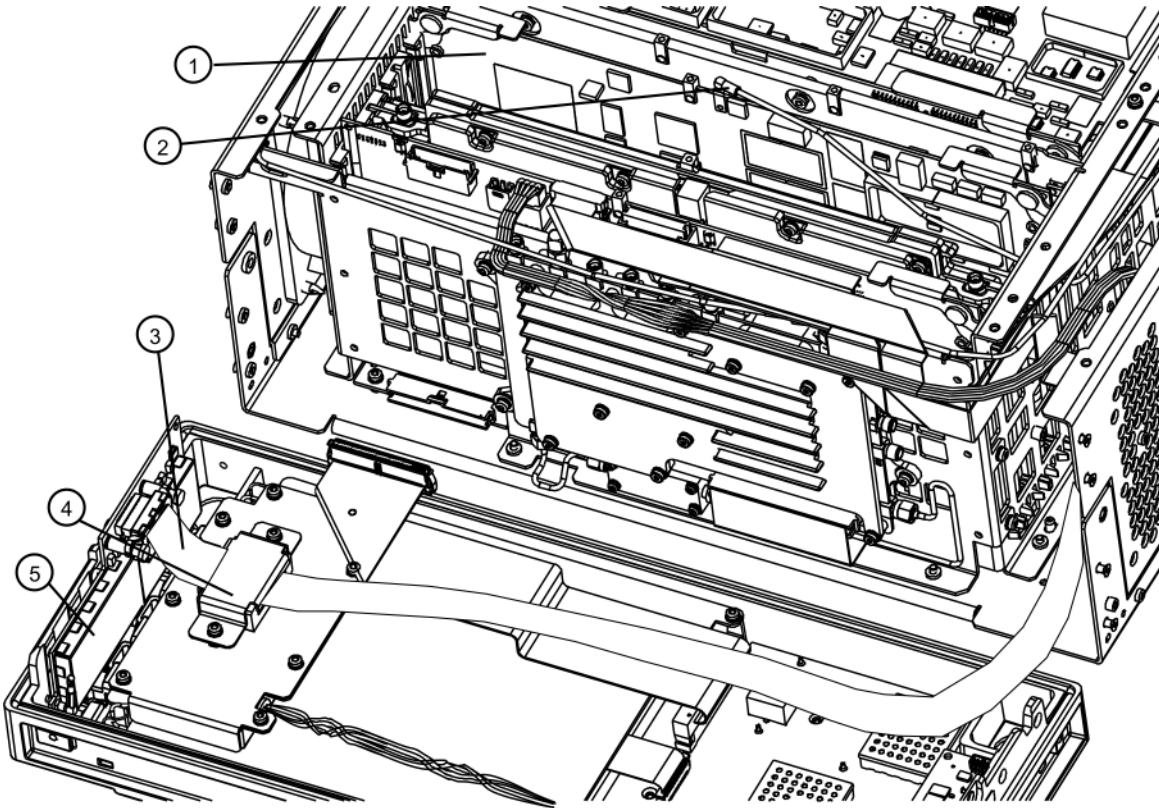
Table 13-34

Item	Description	Keysight Part Number
34	A1W1 Flex Circuit, Display to Front Panel Interface Board	W1312-60122
35	A1W3 Power Cable, Front Panel Interface board to DC-DC Converter Serial Number $\geq$ MY/SG/US51240000	W1312-60130
36	A1W4 Power Cable, DC-DC Converter to Display Serial Number $\geq$ MY/SG/US51240000	W1312-60131

a. Non-orderable item, see A1A1.



Figure 13-36 Option BBA Parts



bbiq\_parts1

Table 13-35

Item	Description	Keysight Part Number
1	A19 BBIQ Main Board (Option BBA)	N9020-60093
2	W25 Cable Assembly, A19J101, BBIQ Main Board to A16J707 Reference Board (Flexible Coax) (Option BBA)	8121-1401
3	W24 Cable Assembly, A18J1, BBIQ Interface Board to A19J1, BBIQ Main Board (Ribbon Cable) (Option BBA)	8121-1683
4	A1MP18 Core Bracket (Option BBA)	N9020-00012
5	A18 BBIQ Interface Board (Option BBA)	N9020-60094

Replaceable Parts  
Hardware

## 14 Assembly Replacement Procedures

### What You Will Find in This Chapter

Procedures in this chapter enable you to locate, remove, and replace the following major assemblies in your instrument.

Refer to **Chapter 13, “Replaceable Parts.”** for part numbers, assembly descriptions, and ordering information.

- “Instrument Outer Case” on page 440
- “Top Brace and Reference Bracket” on page 445
- “RF Area” on page 447
- “RF Front End Assembly” on page 479
- “Front End Control Assembly” on page 481
- “L.O. Synthesizer Assembly” on page 484
- “Rear Panel” on page 486
- “Reference Assembly” on page 487
- “Power Supply Assembly” on page 492
- “CPU Assembly” on page 495
- “Disk Drive” on page 498
- “Analog I.F. (AIF)/Digital I.F. (DIF) Assembly” on page 511
- “Wide Band Analog IF and Digital IF Assemblies” on page 516
- “Midplane Assembly” on page 518
- “Motherboard Assembly” on page 521
- “Fan Assembly” on page 526
- “Input Connector Assembly” on page 529
- “Front Frame Assembly” on page 531
- “Display Assembly - LCD” on page 537
- “Display Assembly - LED” on page 546
- “Inverter Board” on page 550

Assembly Replacement Procedures  
What You Will Find in This Chapter

“Option BBA” on **page 552**

## Before Starting

Before starting to disassemble the instrument:

- Check that you are familiar with the safety symbols marked on the instrument. And, read the general safety considerations and the safety note definitions given in the front of this guide.
- The instrument contains static sensitive components. Read the section entitled “**ESD Information**” on page 21.

## Safety

**WARNING** The opening of covers or removal of parts is likely to expose dangerous voltages. Disconnect the product from all voltage sources while it is being opened.

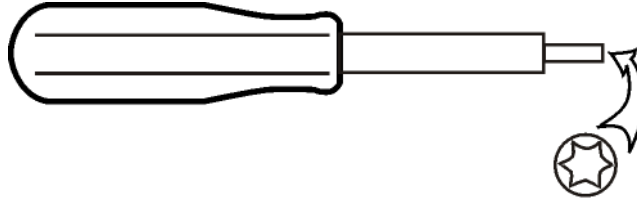
---

**WARNING** The instrument contains potentially hazardous voltages. Refer to the safety symbols on the instrument and the general safety considerations at the beginning of this service guide before operating the unit with the cover removed. Failure to heed the safety precautions can result in severe or fatal injury.

---

## Tools you will need

Figure 14-1 TORX Tool



sl736a

Table 14-1

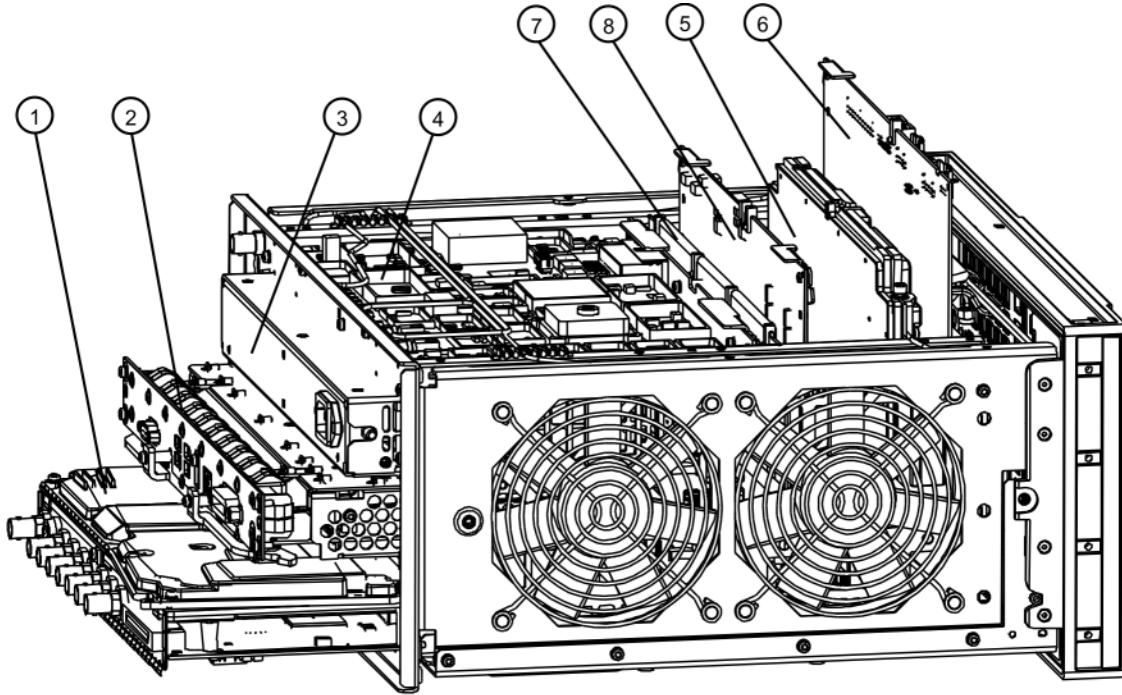
Description	Keysight Part Number
TORX Hand Driver - Size T-10	8710-1623
TORX Hand Driver - Size T-20	8710-1615
9/16 inch nut driver	8720-0008
5/16 inch open-end wrench	source locally
cable puller	5021-6773

## Adjustments Tests after an instrument repair

Refer to [Table 15-1 on page 563](#) for information about post-repair procedures. If one or more instrument assemblies have been repaired or replaced, perform the related adjustments and performance verification tests.

## Major Assembly Locations

Figure 14-2 Major Assemblies



major\_assy

Table 14-2

Item	Description
1	A2 Analog I.F. Assembly/A3 Digital I.F. Assembly
2	A4 CPU Assembly
3	A6 Power Supply
4	A16 Reference Assembly
5	A14 L.O. Synthesizer Assembly
6	A15 Front End Control Assembly
7	A7 Midplane Assembly
8	<b>A19 BBIQ Main Board (Option BBA)</b>

## Instrument Outer Case

**CAUTION** If the instrument is placed on its face during any of the following procedures, be sure to use the front panel protective cover (MP50), a soft surface, or soft cloth to avoid damage to the front panel, keys, or input connector.

---

**NOTE** If the analyzer has Option PRC, Portable Configuration, refer to the “**Option PRC**” section on [page 442](#) to remove the outer case.

---

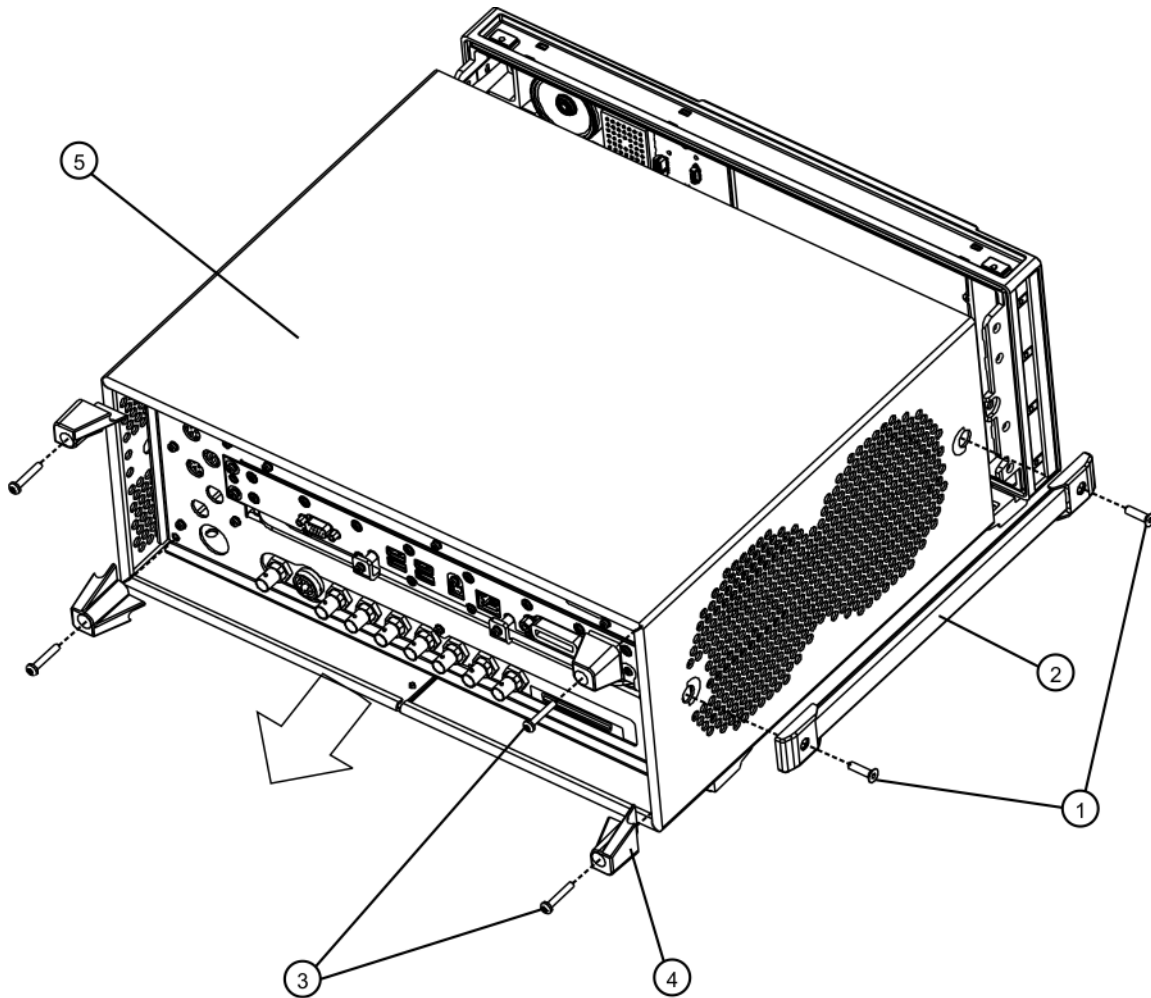
### Standard Instrument

#### Removal

1. Disconnect the instrument from ac power.
2. Refer to [Figure 14-3](#). Using the T-20 driver, remove the four screws (two on each side) **(1)** that attach the handle strap **(2)** on each side of the instrument.
3. Using the T-20 driver, remove the four screws (including washers) **(3)** (two on each side) that hold the rear feet **(4)** (two on each side) in place.
4. Pull the instrument cover **(5)** off towards the rear of the instrument.



Figure 14-3 Standard Instrument Outer Case Removal



outer\_case

### Replacement

1. Disconnect the instrument from ac power.
2. Slide the instrument cover back onto the deck from the rear. The seam on the cover should be on the bottom. Be sure the cover seats into the gasket groove in the Front Frame Assembly.
3. Replace the four rear feet to the rear of the instrument (two on each side). Torque the rear feet screws to 21 inch pounds.
4. Replace the handle straps on both sides of the instrument. Torque the handle strap screws to 21 inch pounds.

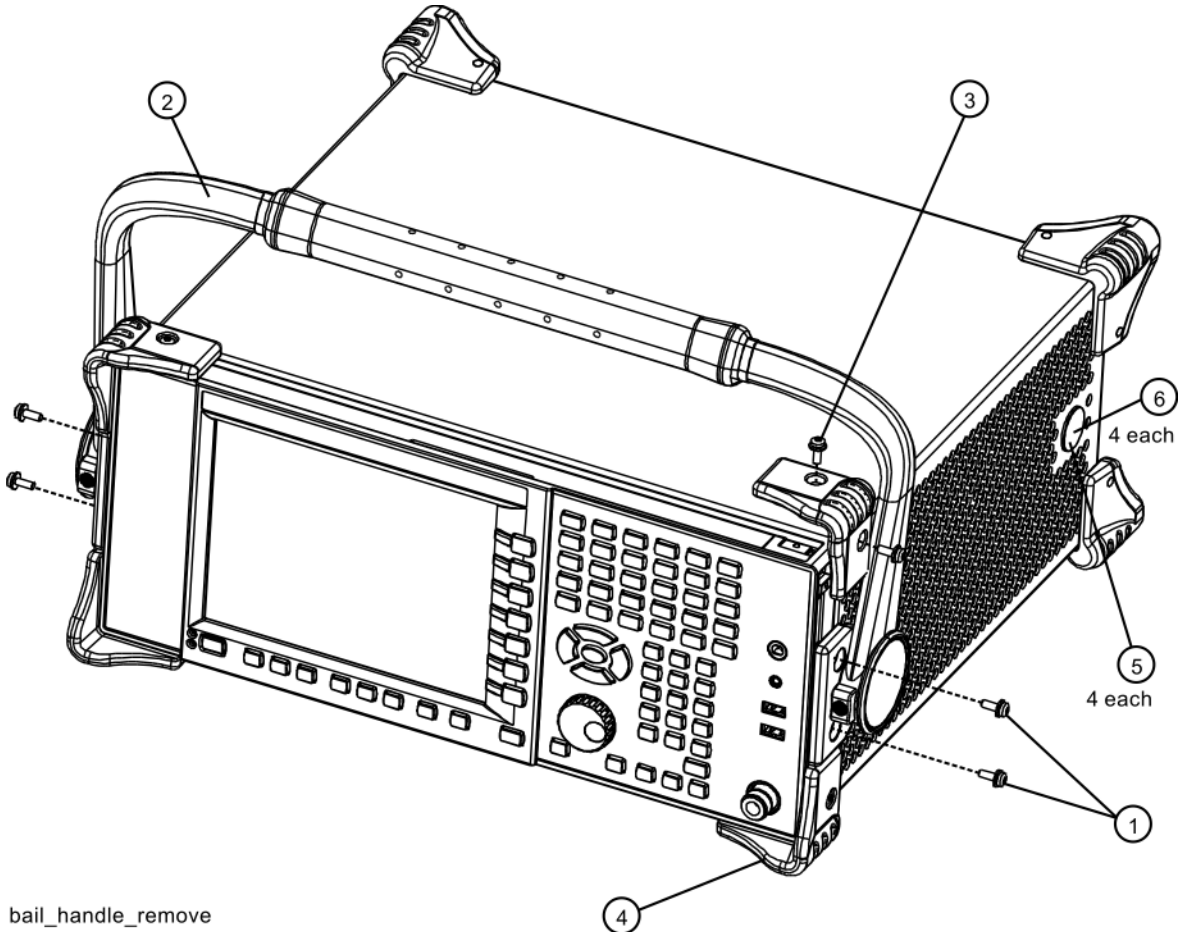
## Option PRC

### Removal

1. Disconnect the instrument from ac power.

Refer to **Figure 14-4**. Using the T-20 driver, remove the four screws (two on each side) (1) that hold the bail handle (2) to the front frame.

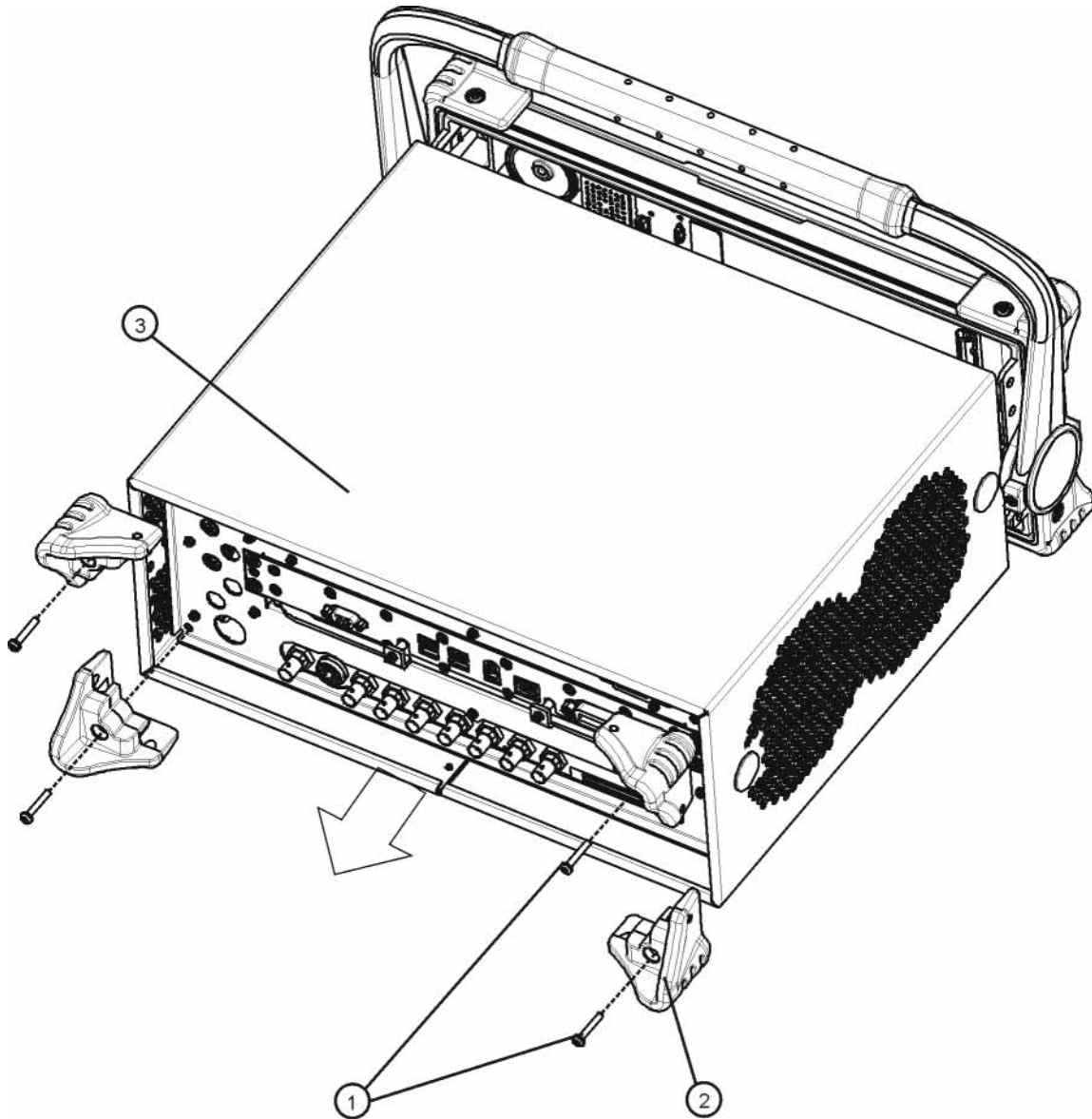
**Figure 14-4** Bail Handle Removal



2. Using the T-20 driver, remove the four screws (two on each side) (6) that hold the strap handle plugs (5) in place.

3. Refer to **Figure 14-5**. Using the T-20 driver, remove the four screws including washers (1) that hold the rear bumpers (2) (two on each side) in place.

**Figure 14-5** Option PRC Instrument Outer Case Removal



rear\_bumper\_remove

4. Pull the instrument cover (3) off towards the rear of the instrument.

## Replacement

1. Disconnect the instrument from ac power.
2. Slide the instrument cover back onto the deck from the rear. The seam on the cover should be on the bottom. Be sure the cover seats into the gasket groove in the Front Frame Assembly.
3. Refer to **Figure 14-4**. Replace the strap handle plugs **(5)** in place and attach using the T-20 driver to replace the four screws (two on each side) **(6)**. Torque to 21 inch pounds.
4. Place the bail handle into position on the front frame and using the T-20 driver, replace the four screws (two on each side) **(1)** that hold the bail handle **(2)** to the front frame. Torque to 21 inch pounds.
5. Refer to **Figure 14-5**. Replace the four rear bumpers to the rear of the instrument. Torque to 21 inch pounds.

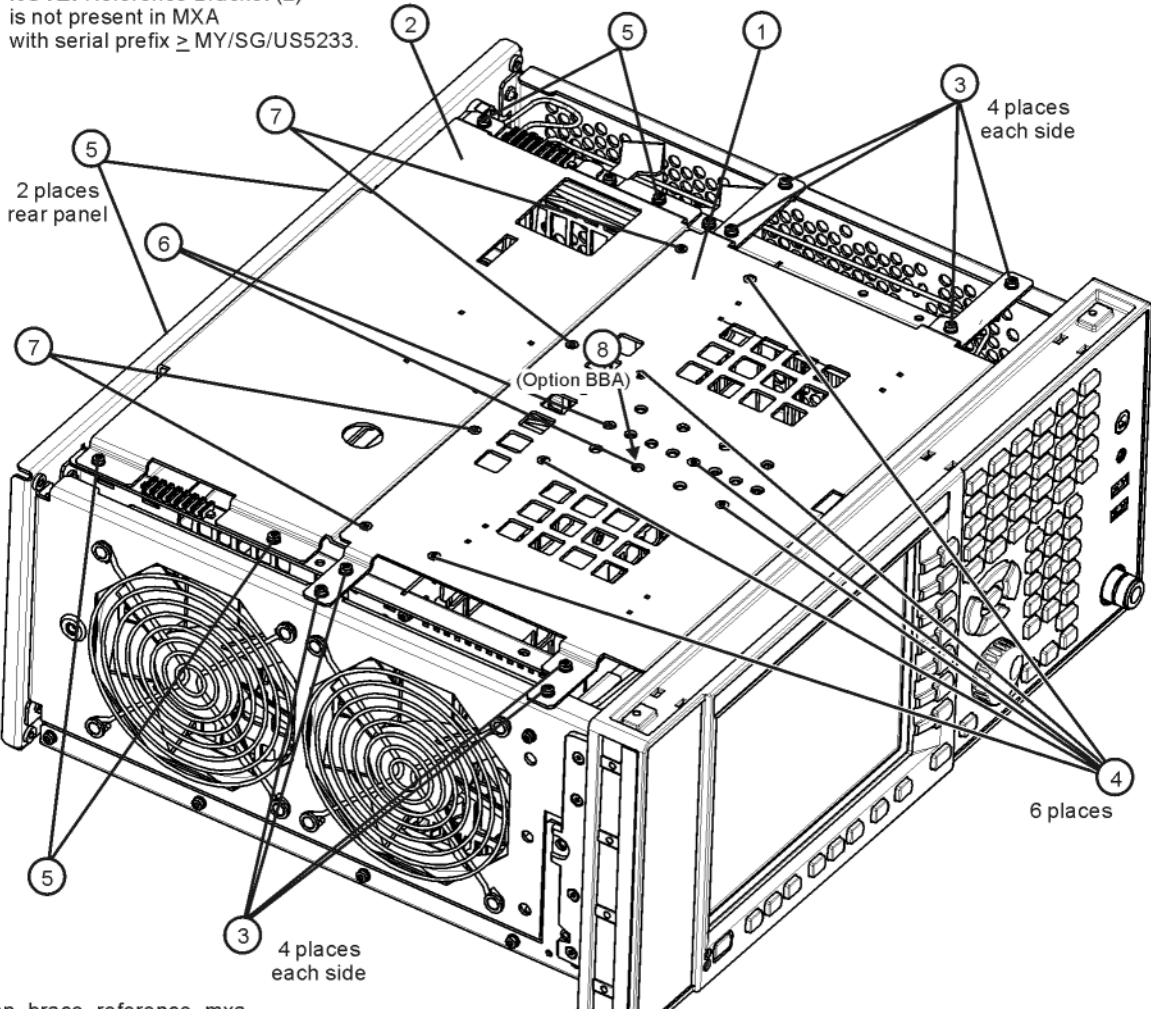
## Top Brace and Reference Bracket

### Removal

1. Remove the instrument outer case. Refer to the Instrument Outer Caseremoval procedure.
2. Refer to **Figure 14-6**. On analyzers with serial prefix < MY/SG/US5233, both the Top Brace **(1)** and the Reference Bracket **(2)** will be present. On analyzers with serial prefix ≥ MY/SG/US5233 or any analyzer with Option B85, B1A, or B1X only the Top Brace **(1)** will be present.
3. To remove the Top Brace, use the T-10 driver to remove the eight screws **(3)** (0515-0372) attaching the Top Brace to the chassis. Remove the six flathead screws **(4)** (0515-1227) attaching the Top Brace to the A7 Midplane, A14 LO Synthesizer, and A15 Front End Controller assemblies. Remove the four flathead screws **(7)** (0515-1227) securing the Top Brace to either the Reference Bracket or the A16 Reference assembly.
4. If Option BBA is installed, remove the flathead screw **(8)** (0515-1227) securing the Top Brace to the BBIQ Main Board.
5. If either Option B85, B1A, or B1X is installed, remove the two flathead screws **(6)** (0515-1227) securing the Top Brace to the A25 Wideband Analog IF and A26 Wideband Digital IF assemblies.
6. To remove the Reference Bracket **(2)** (if present), use the T-10 driver to remove the six screws **(5)** (including two at the rear panel) attaching the Reference Bracket to the instrument.

Figure 14-6 Top Brace and Reference Bracket Removal

**NOTE:** Reference Bracket (2)  
is not present in MXA  
with serial prefix  $\geq$  MY/SG/US5233.



### Replacement

1. Refer to **Figure 14-6**. To replace the Top Brace or the Reference Bracket, place them into the correct position and attach the appropriate screws. Torque to 9 inch-pounds.

## RF Area

Refer to **Figure 14-7** and **Figure 14-8**. The RF area consists of RF attenuator A **(1)**, RF attenuator B **(2)**, low band switch assembly **(3)**, and YTF Preselector **(4)**.

Instruments with Options DP2, MPB, or B40 will also have coaxial switch #1 **(5)**, coaxial switch #2 **(6)**, and 6 dB fixed attenuator **(7)** (**Figure 14-8**).

**NOTE** The YTF Preselector is not typically installed in instruments with Option 503.

Figure 14-7 RF Area Components and Cables - Standard Instruments

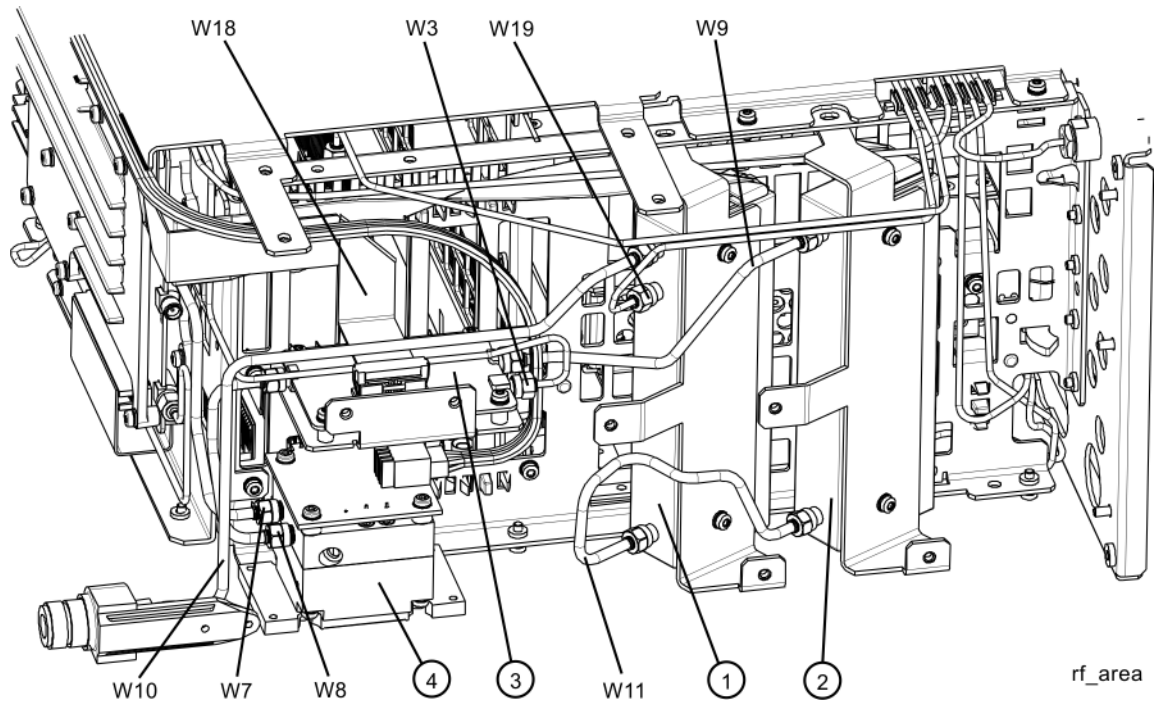
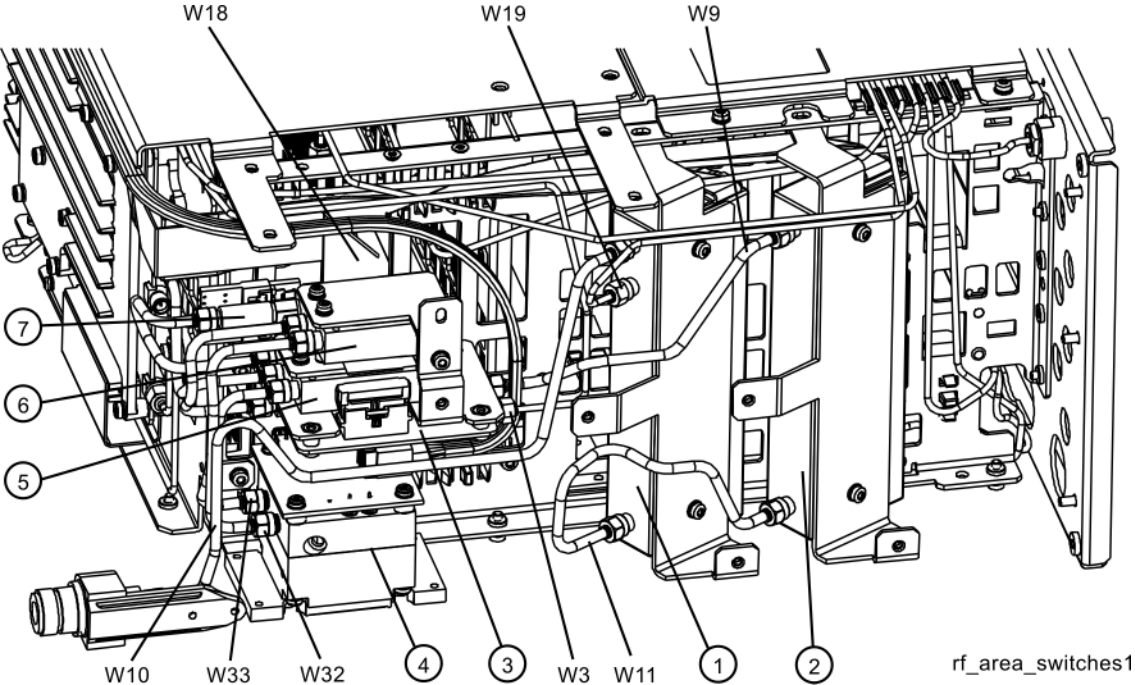


Figure 14-8 RF Area Components and Cables - Options DP2, MPB, B40

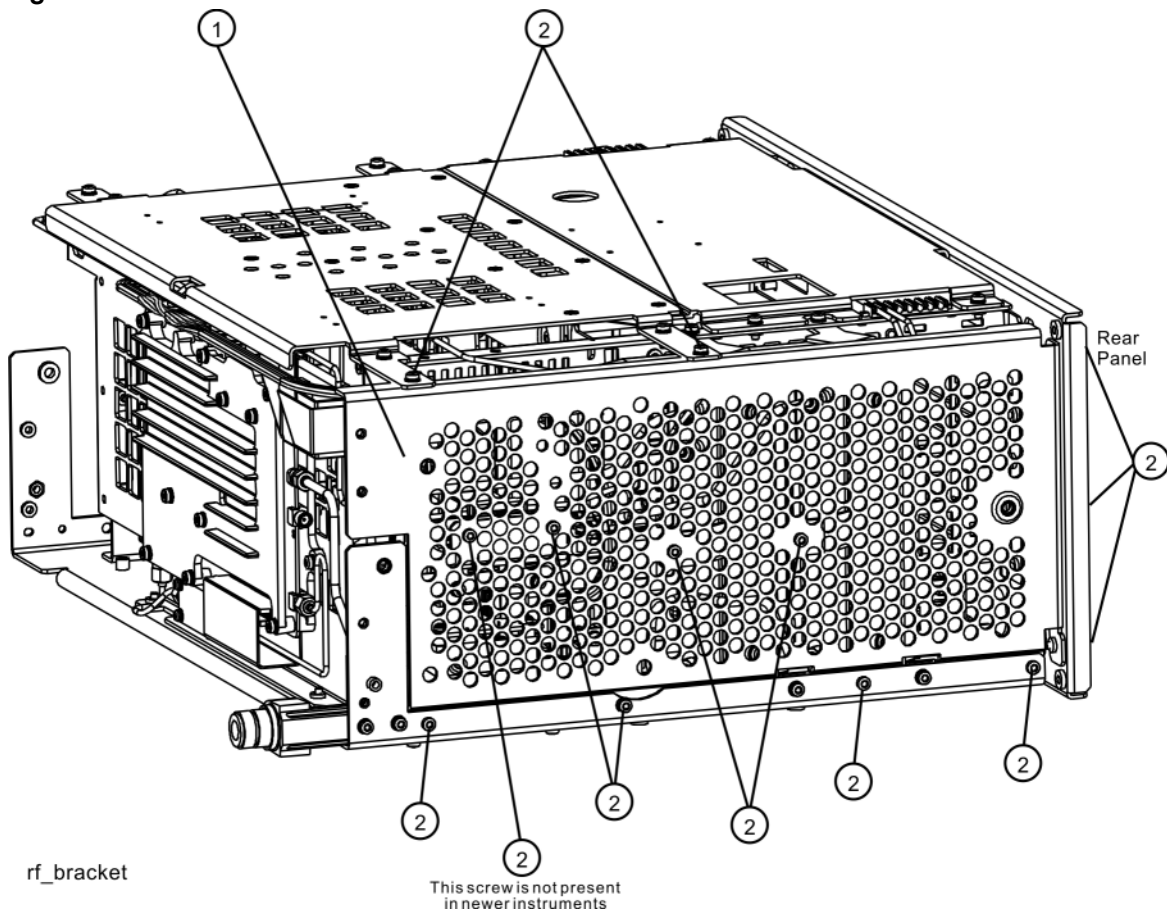




To gain access to any of these parts, follow these steps:

1. Remove the instrument outer case. Refer to the Instrument Outer Caseremoval procedure.
2. Remove the top brace. Refer to the **Front Frame Assembly** removal procedure.
3. Remove the front panel. Refer to the **Front Frame Assembly** removal procedure.
4. Refer to **Figure 14-9**. Remove the chassis side, right (1) by removing the thirteen screws (2) using the T-10 driver.

**Figure 14-9** RF Bracket Removal



Low Band Switch -  
Standard Instruments with Serial Number < MY/SG50510001

**Removal**

1. Refer to **Figure 14-10**. Remove the ribbon cable W18.
2. Remove the semi-rigid cables W3, W8, and W9 using the 5/16 inch wrench.

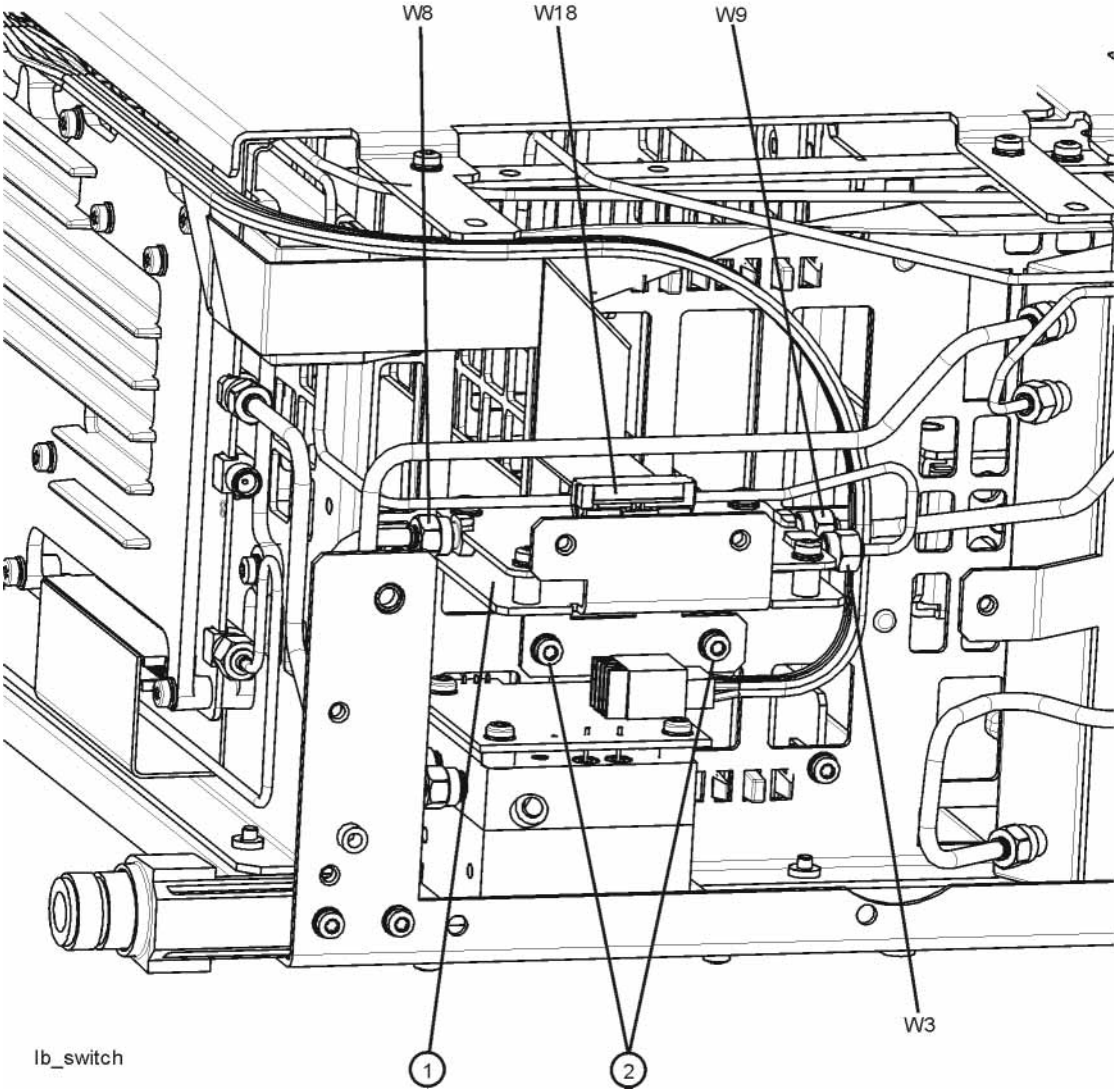
**NOTE**

W8 will not be present in instruments with Option 503.

---

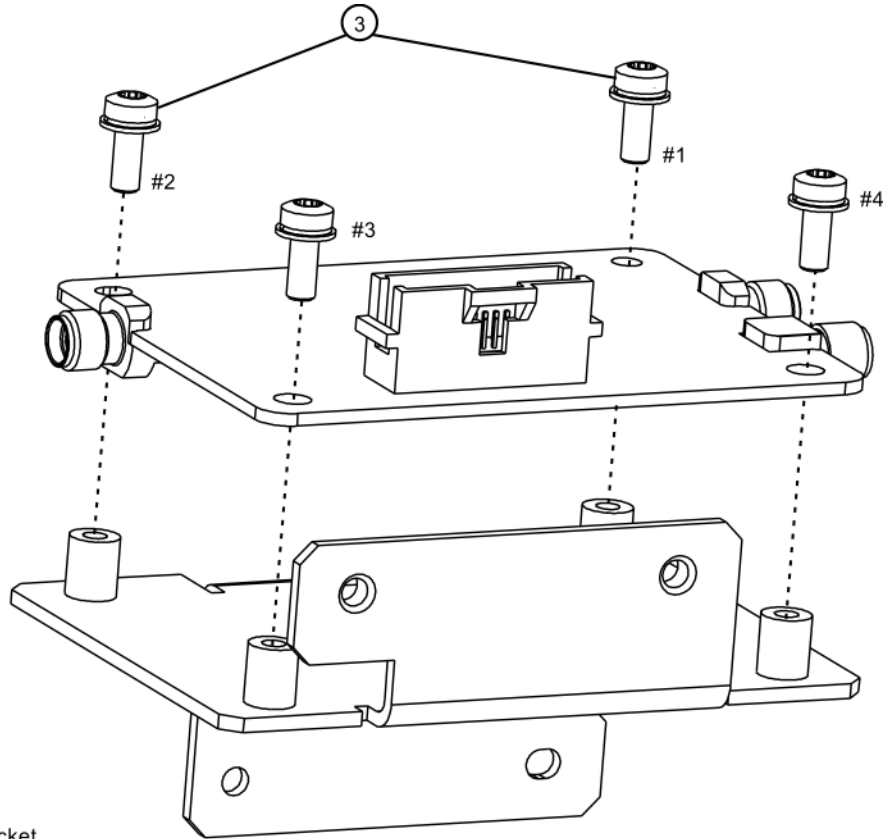
3. Remove the two screws **(2)** using the T-10 driver. The low band switch **(1)** can now be removed from the chassis.

**Figure 14-10** Low Band Switch Removal



4. Refer to **Figure 14-11**. To separate the switch from the bracket, remove the four screws (**3**) using the T-10 driver.

**Figure 14-11** Low Band Switch and Bracket Separation



lb\_switch\_bracket

## Replacement

1. Refer to **Figure 14-11**. Place the switch onto the bracket and replace the four screws **(3)**. Torque to 9 inch-pounds in the sequence shown, starting with #1.
2. Place the switch/bracket into place into the chassis and replace the two screws. Torque to 9 inch-pounds starting with the screw closest to the front of the instrument.
3. Refer to **Figure 14-10**. Replace the semi-rigid cables W3, W8, and W9. Torque to 10 inch-pounds.

### NOTE

W8 will not be present in instruments with Option 503.

---

4. Replace the ribbon cable W18.
5. Refer to **Figure 14-9**. Position the chassis side, right onto the chassis and replace the thirteen screws. Torque to 9 inch-pounds.
6. Replace the front panel. Refer to the **Front Frame Assembly** replacement procedure.
7. Replace the top brace. Refer to the Top Brace and Reference Bracket replacement procedure.
8. Replace the instrument outer case. Refer to the Instrument Outer Casereplacement procedure.

Low Band Switch -  
Standard Instruments with Serial Number > MY/SG50510001

**Removal**

1. Refer to **Figure 14-12**. Remove the ribbon cable W18.
2. Remove the semi-rigid cables W3, W8, and W9 using the 5/16 inch wrench.

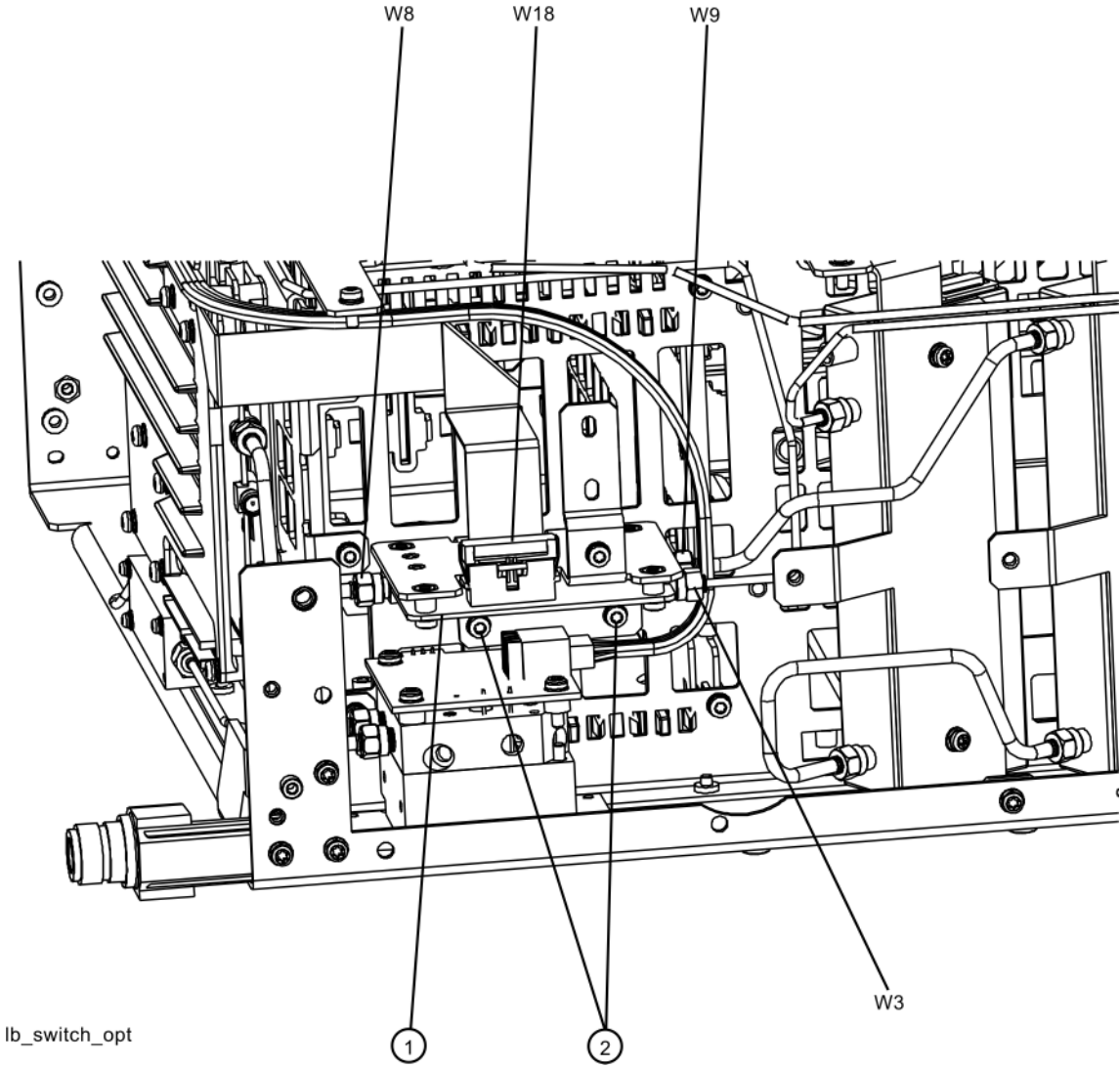
**NOTE**

W8 will not be present in instruments with Option 503.

---

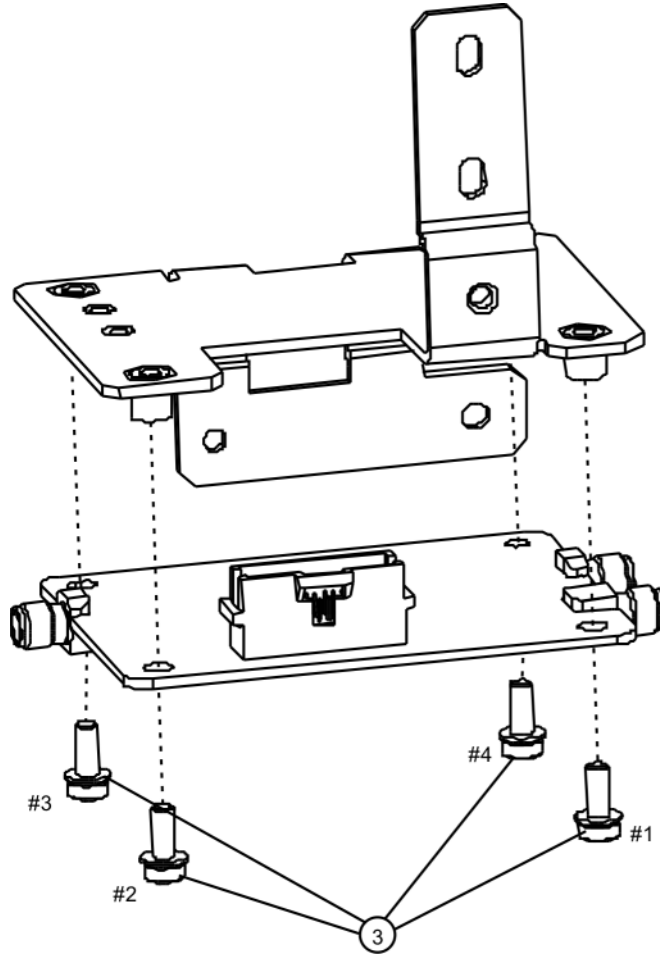
3. Remove the two screws **(2)** using the T-10 driver. The low band switch **(1)** can now be removed from the chassis.

**Figure 14-12** Low Band Switch Removal



4. Refer to **Figure 14-13**. To separate the switch from the bracket, remove the four screws (3) using the T-10 driver.

**Figure 14-13** Low Band Switch and Bracket Separation



LB\_switch\_brack\_b40



## Replacement

1. Refer to **Figure 14-13**. Place the switch onto the bracket and replace the four screws **(3)**. Torque to 9 inch-pounds in the sequence shown, starting with #1.
2. Place the switch/bracket into place into the chassis and replace the two screws. Torque to 9 inch-pounds starting with the screw closest to the front of the instrument.
3. Refer to **Figure 14-12**. Replace the semi-rigid cables W3, W8, and W9. Torque to 10 inch-pounds.

### NOTE

W8 will not be present in instruments with Option 503.

---

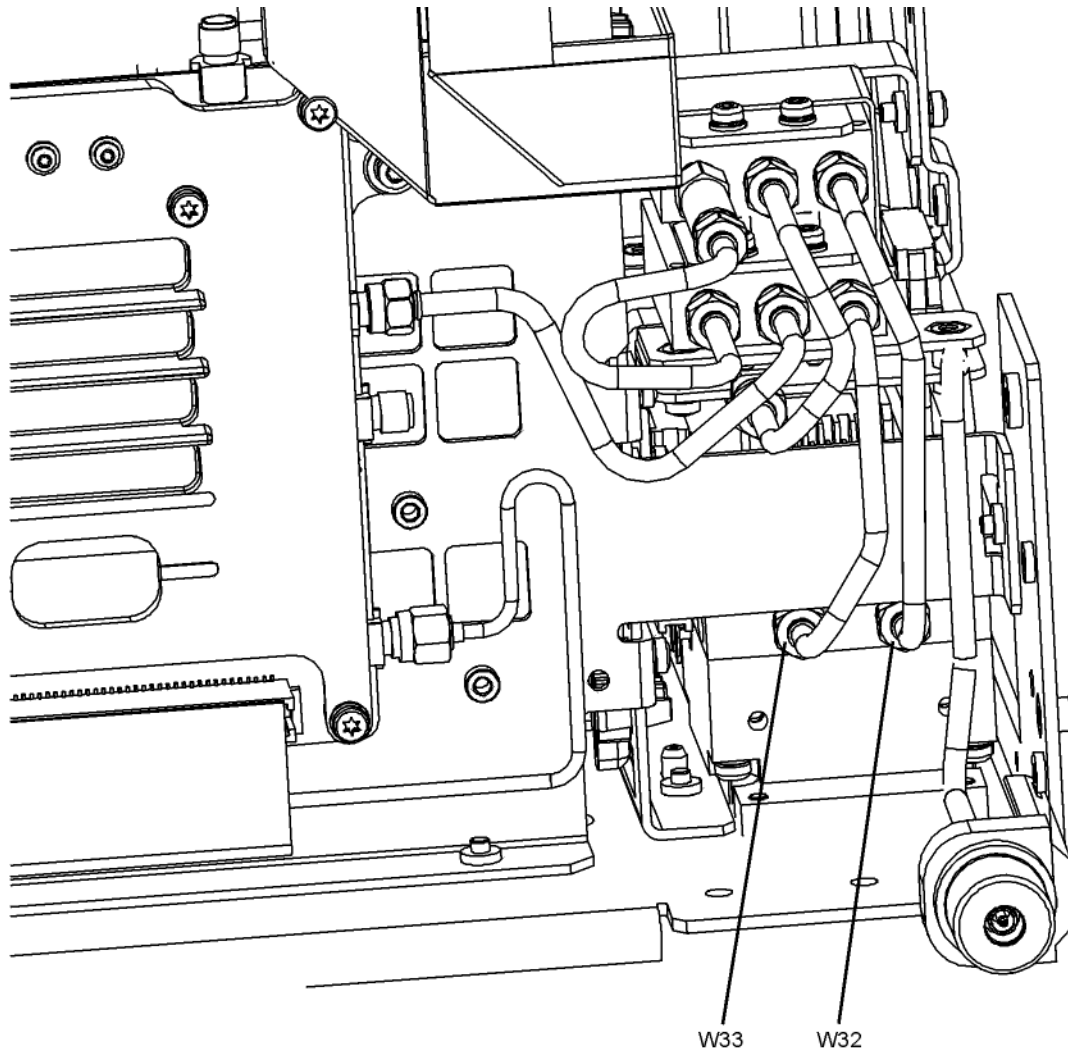
4. Replace the ribbon cable W18.
5. Refer to **Figure 14-9**. Position the chassis side, right onto the chassis and replace the thirteen screws. Torque to 9 inch-pounds.
6. Replace the front panel. Refer to the **Front Frame Assembly** replacement procedure.
7. Replace the top brace. Refer to the Top Brace and Reference Bracket replacement procedure.
8. Replace the instrument outer case. Refer to the Instrument Outer Casereplacement procedure.

Low Band Switch and Coaxial Switches  
Options DP2, MPB, B40

Removal

1. Refer to **Figure 14-14**. Remove semi-rigid coax cables W32 and W33.

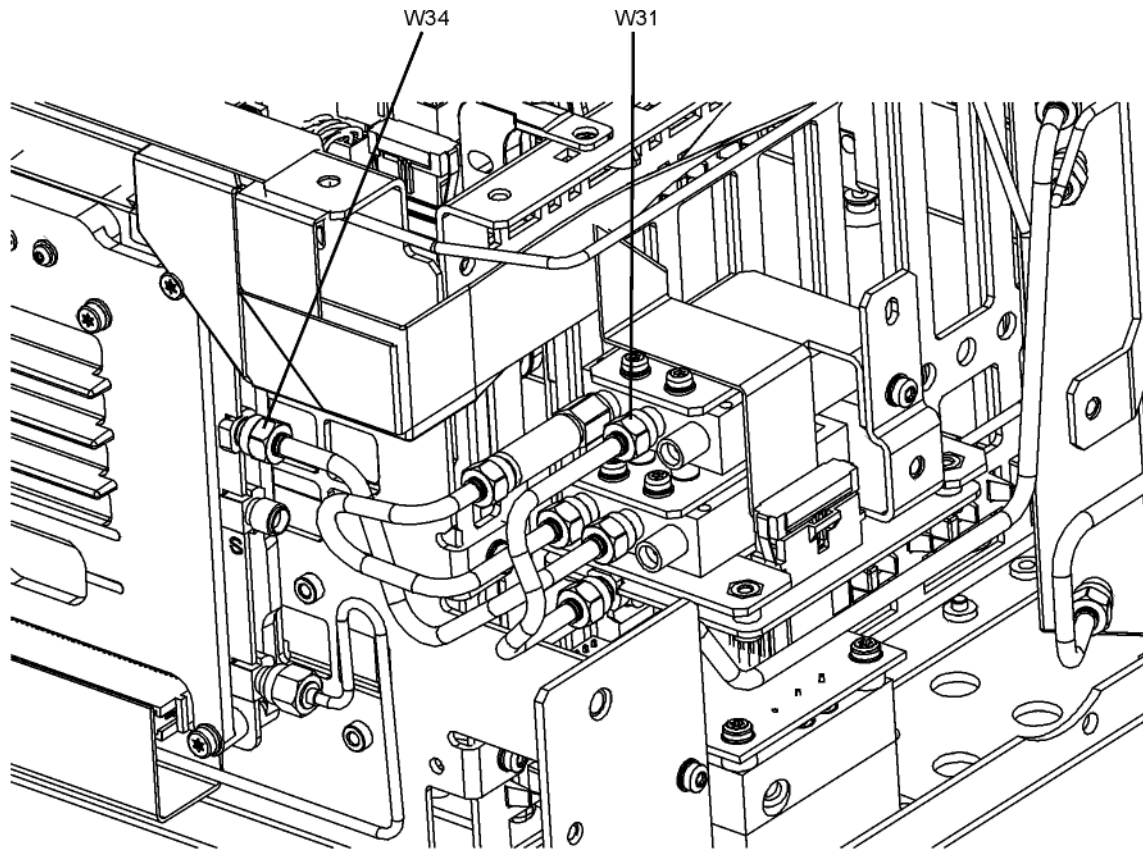
**Figure 14-14** Remove W33 and W32



w33\_w32

2. Refer to **Figure 14-15**. Remove semi-rigid coax cables W31 and W34.

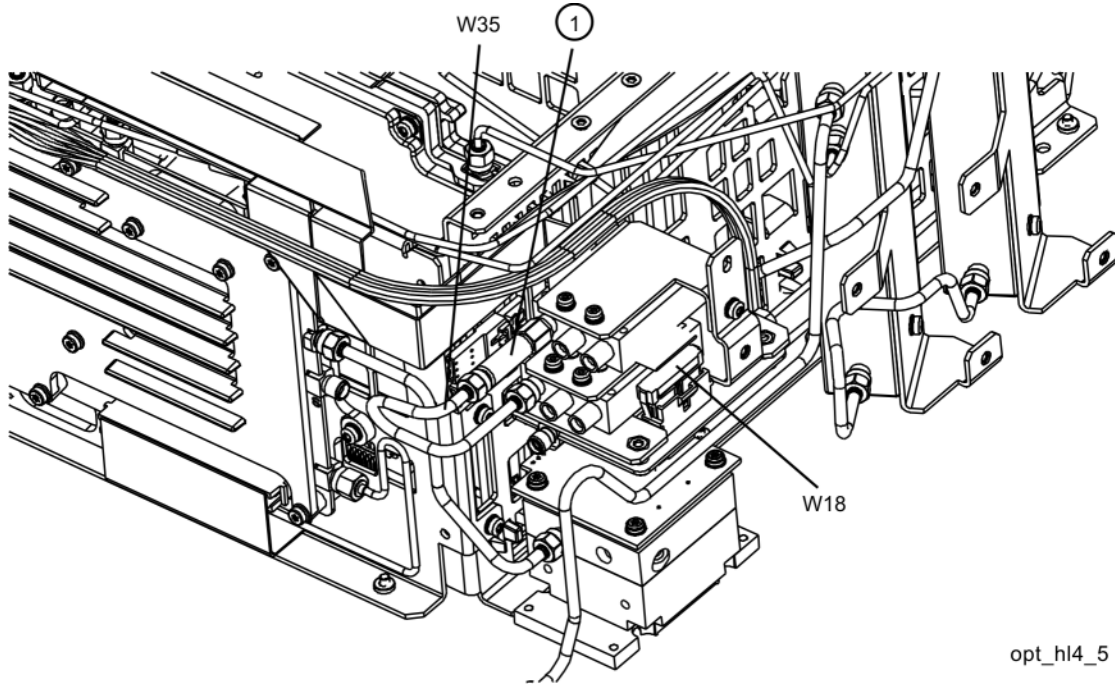
**Figure 14-15** Remove W34 and W31



w34\_w31

3. Refer to **Figure 14-16**. Remove semi-rigid coax cable W35 and the fixed attenuator (1).

**Figure 14-16** W35 and Attenuator Removal



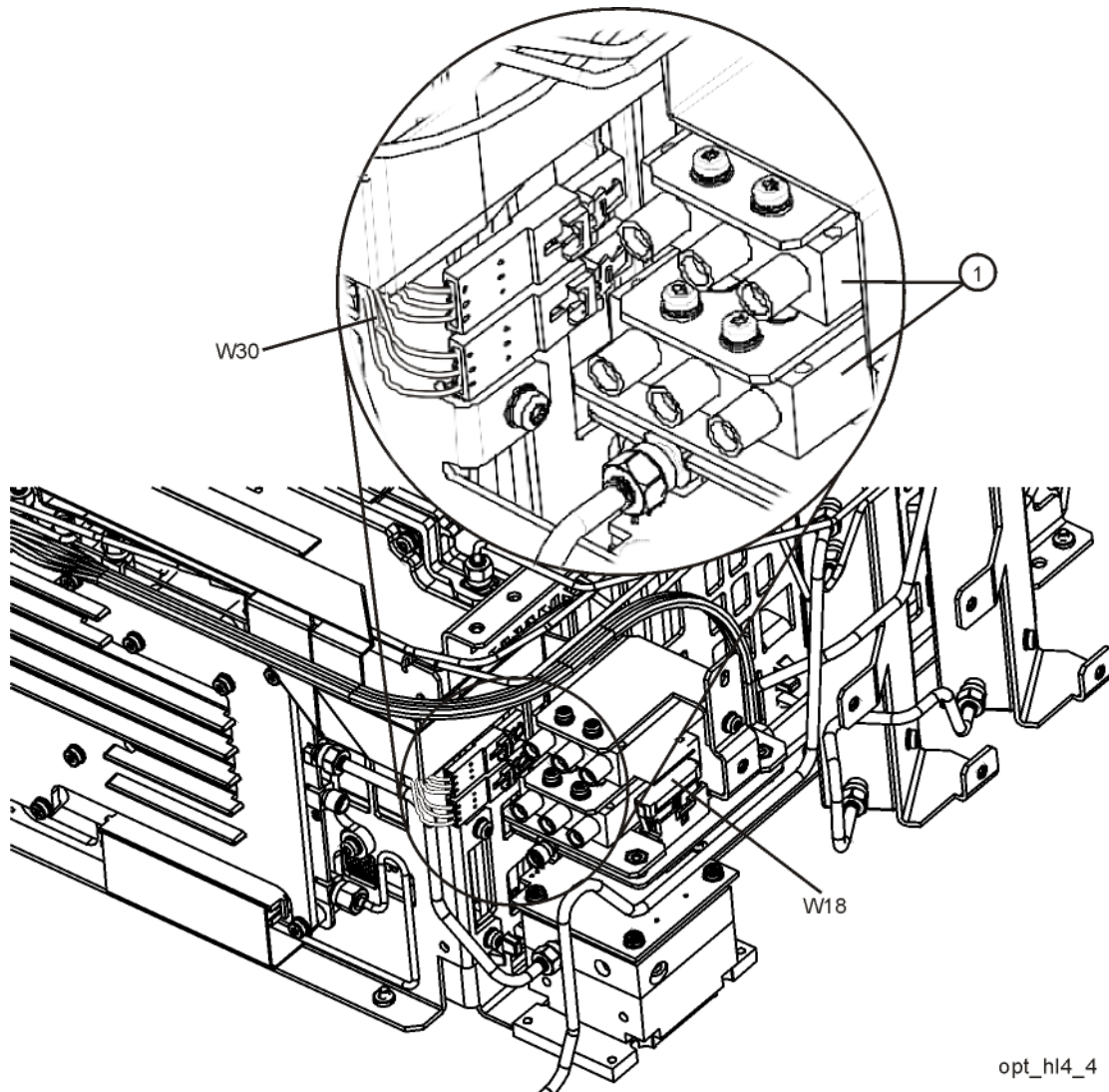
opt\_hl4\_5

4. Remove ribbon cable W18 from J4 of the A11 Low Band Switch.

5. Refer to **Figure 14-17**. Disconnect the two wire harness connectors W30 from the switches (1).

**NOTE** Even though the wire colors on W30 harness are different, it does not matter which one plugs into which switch.

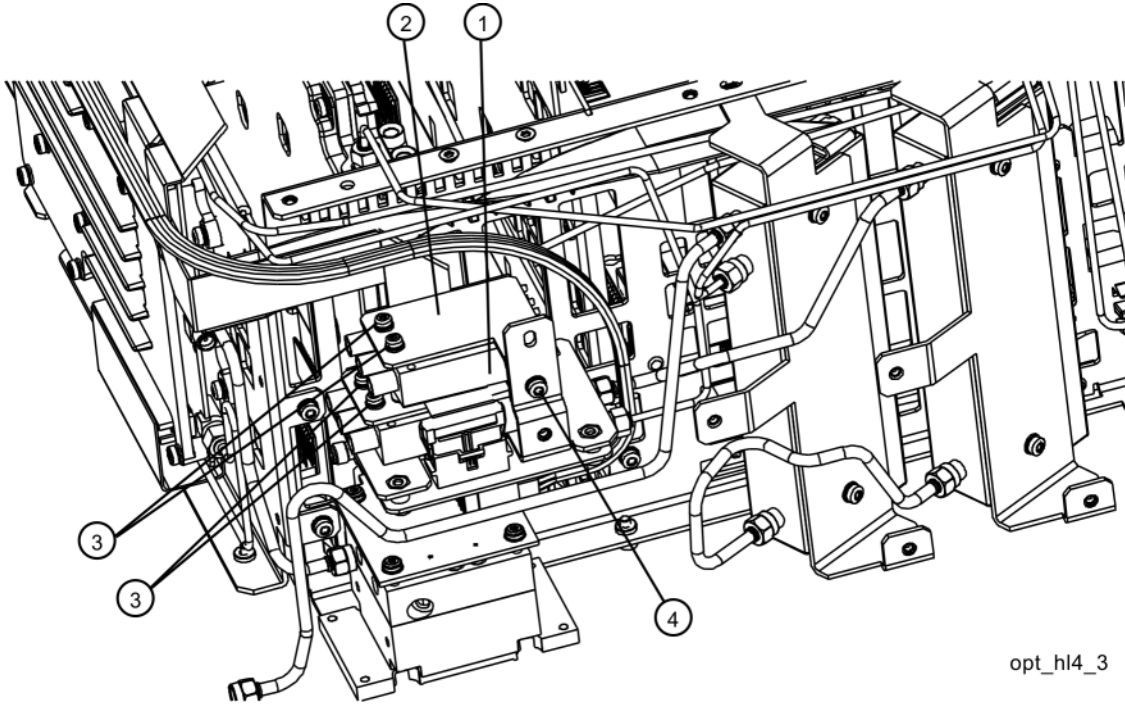
**Figure 14-17** Wire Harness Disconnect



opt\_hl4\_4

6. Refer to **Figure 14-18**. Using the T-10 driver, remove the single screw (4) to separate the switch 2/bracket assembly (1)/(2) from the low band switch bracket. To separate switch 2 (1) from it's bracket (2), remove the two 0515-1992 screws (3) using the T-8 driver.

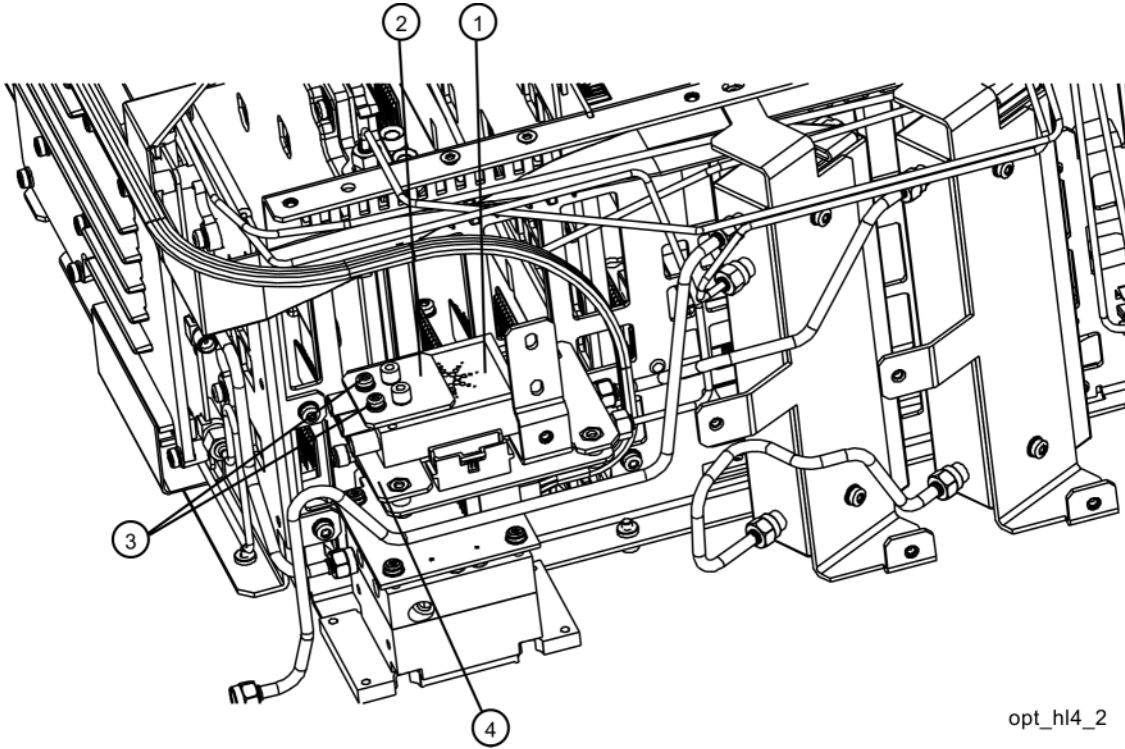
**Figure 14-18** Switch 2 Removal



opt\_hl4\_3

7. Refer to **Figure 14-19**. Using the T-8 driver, remove the two 0515-1992 screws (3) to separate the #1 switch/bracket assembly (1)/(2) from the low band switch bracket (4).

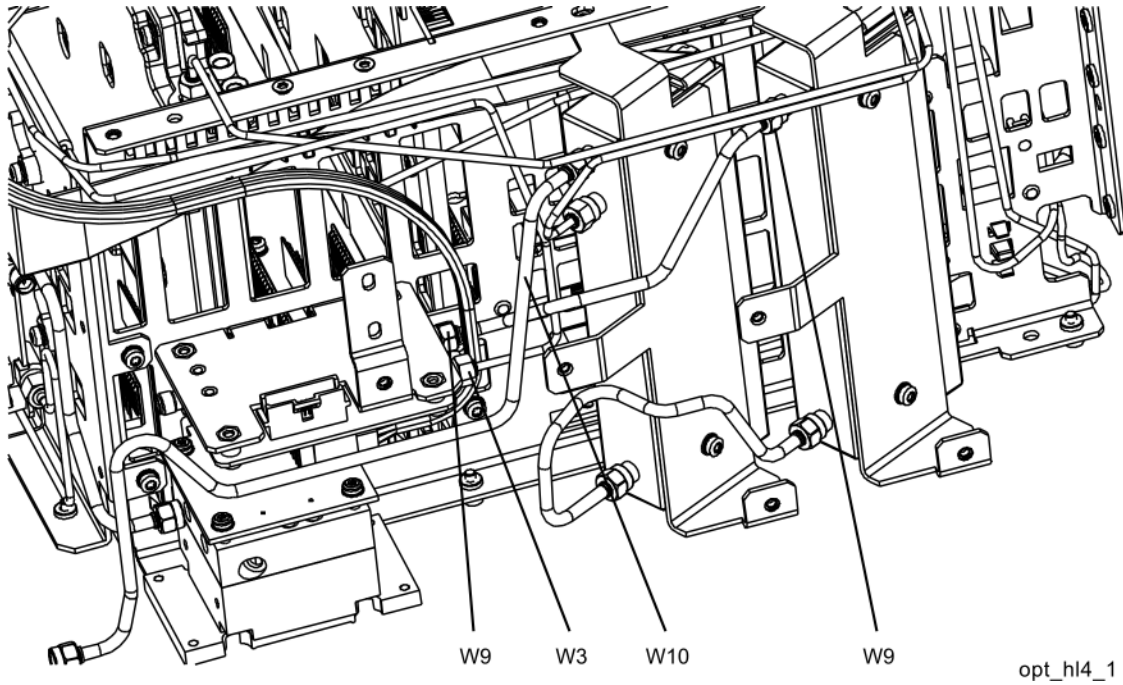
**Figure 14-19** Switch 1 Removal



opt\_h14\_2

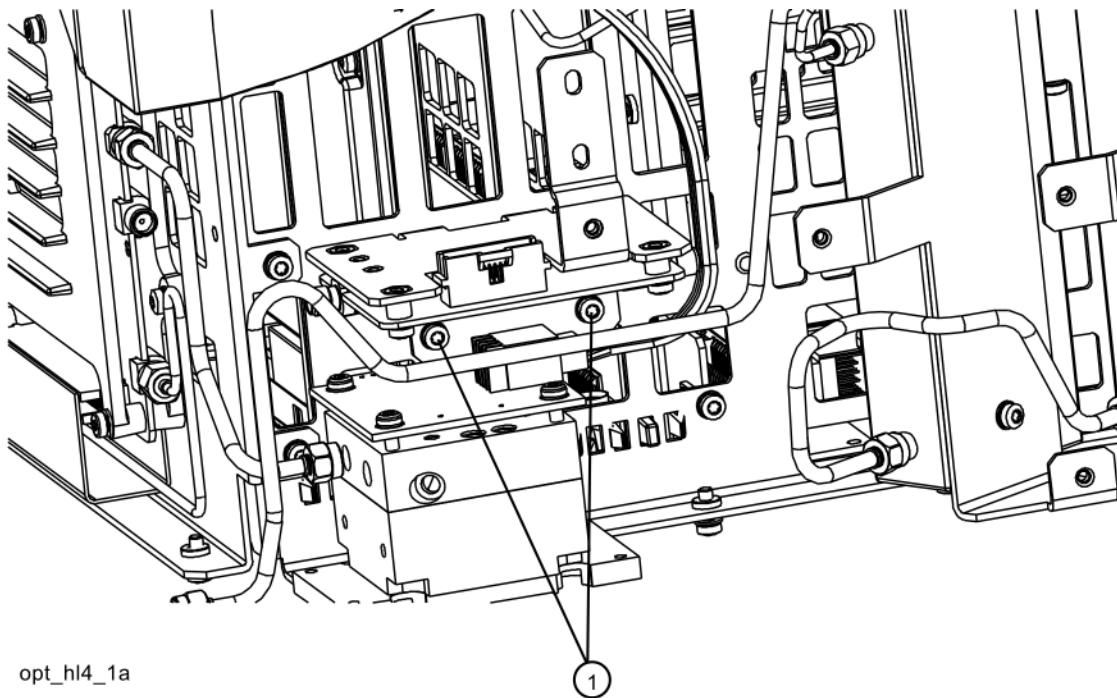
8. Refer to **Figure 14-20**. Remove the semi-rigid cables W3, W9, and W10.

**Figure 14-20** Removing Coax Cables



9. Refer to **Figure 14-21**. Using the T-10 driver, remove the two screws (1) to separate the low band switch/bracket from the chassis.

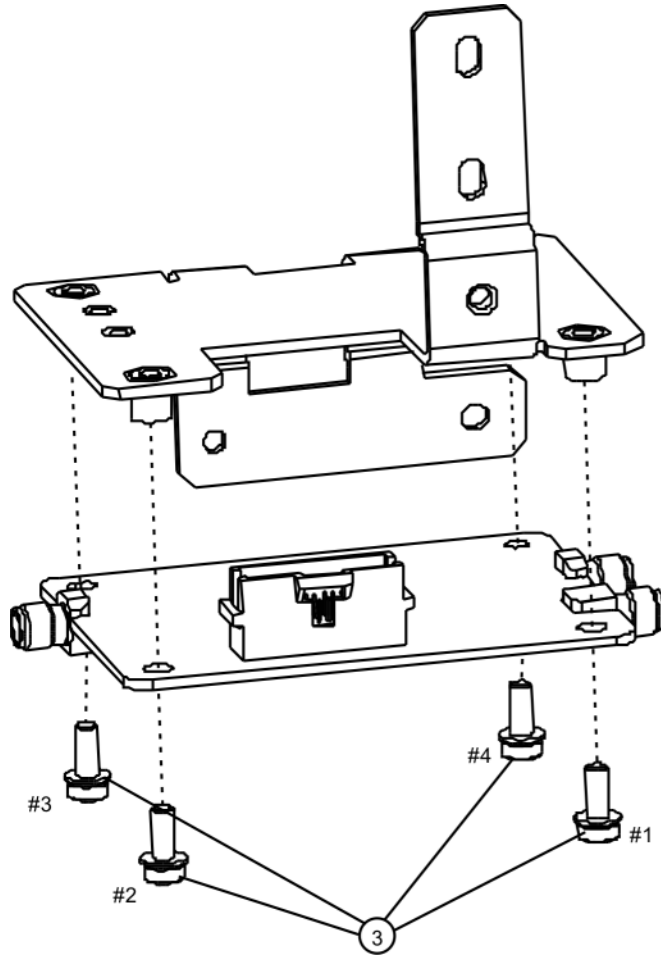
**Figure 14-21** Low Band Switch/Bracket Removal





10. Refer to **Figure 14-22**. To separate the low band switch from the bracket, use the T-10 driver to remove the four screws (3).

**Figure 14-22** Low Band Switch and Bracket Separation

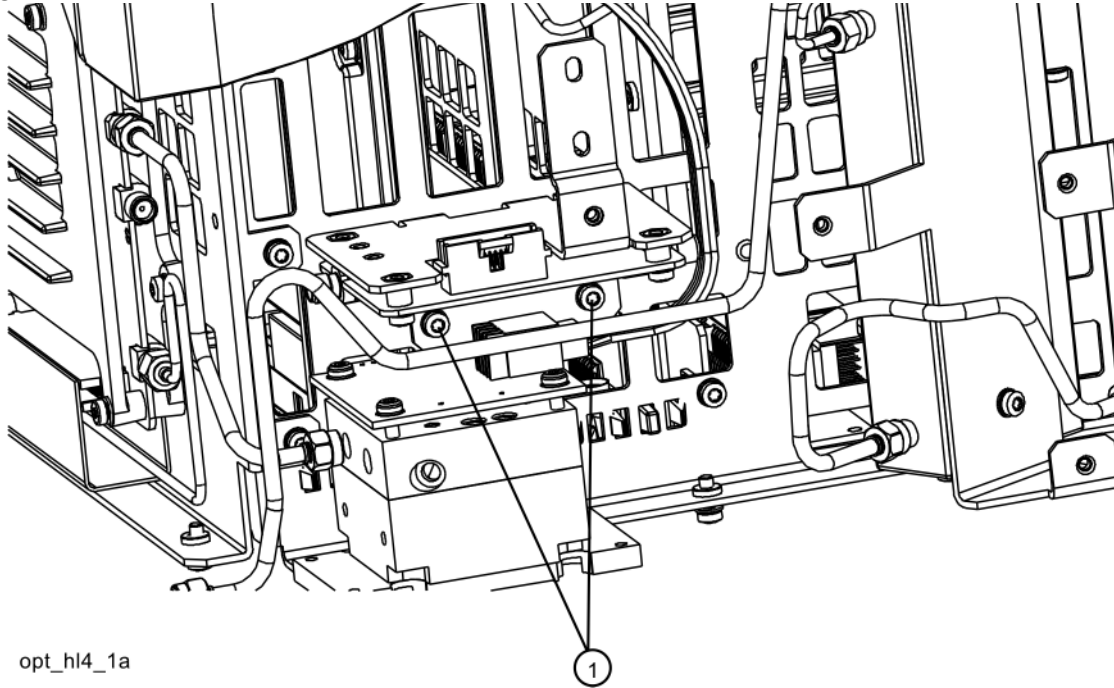


LB\_switch\_brack\_b40

## Replacement

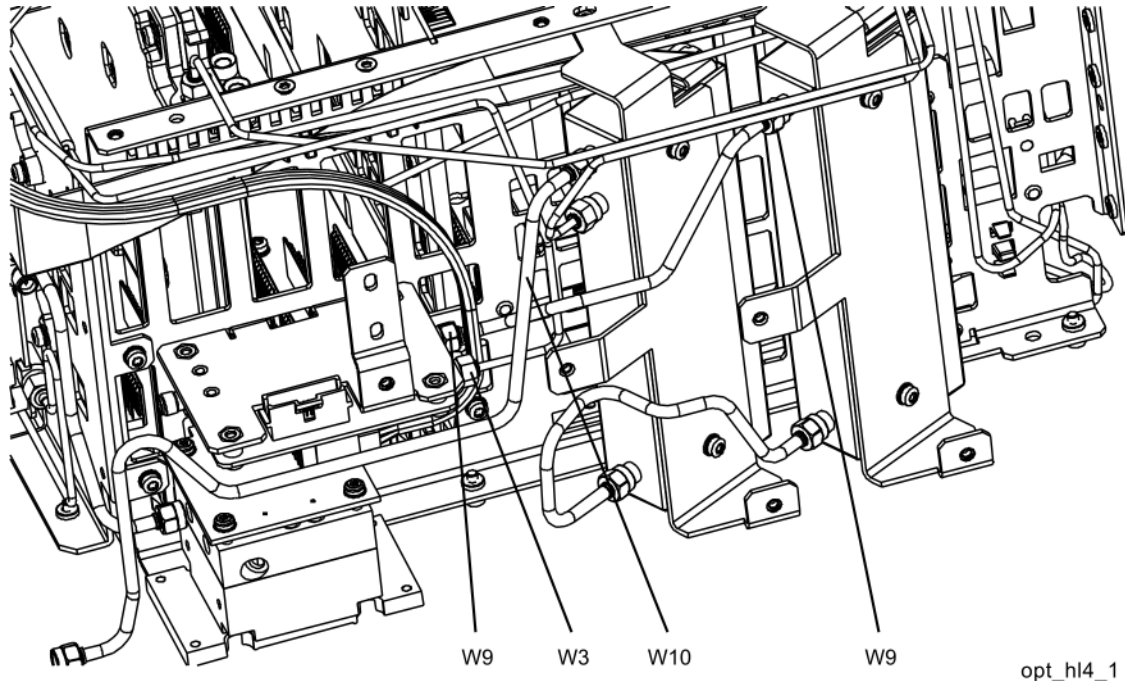
1. Refer to **Figure 14-22**. Place the switch onto the low band switch bracket and replace the four screws (3). Torque to 9 inch-pounds in the sequence shown, starting with #1.
2. Refer to **Figure 14-23**. Place the switch/bracket into place onto the chassis and replace the two screws. Torque to 9 inch-pounds starting with the screw closest to the front of the instrument.

**Figure 14-23** Bracket Installation



3. Refer to **Figure 14-24**. Install W9 between the output of the A10 Input Attenuator and A11J1. Torque to 10 inch-pounds.

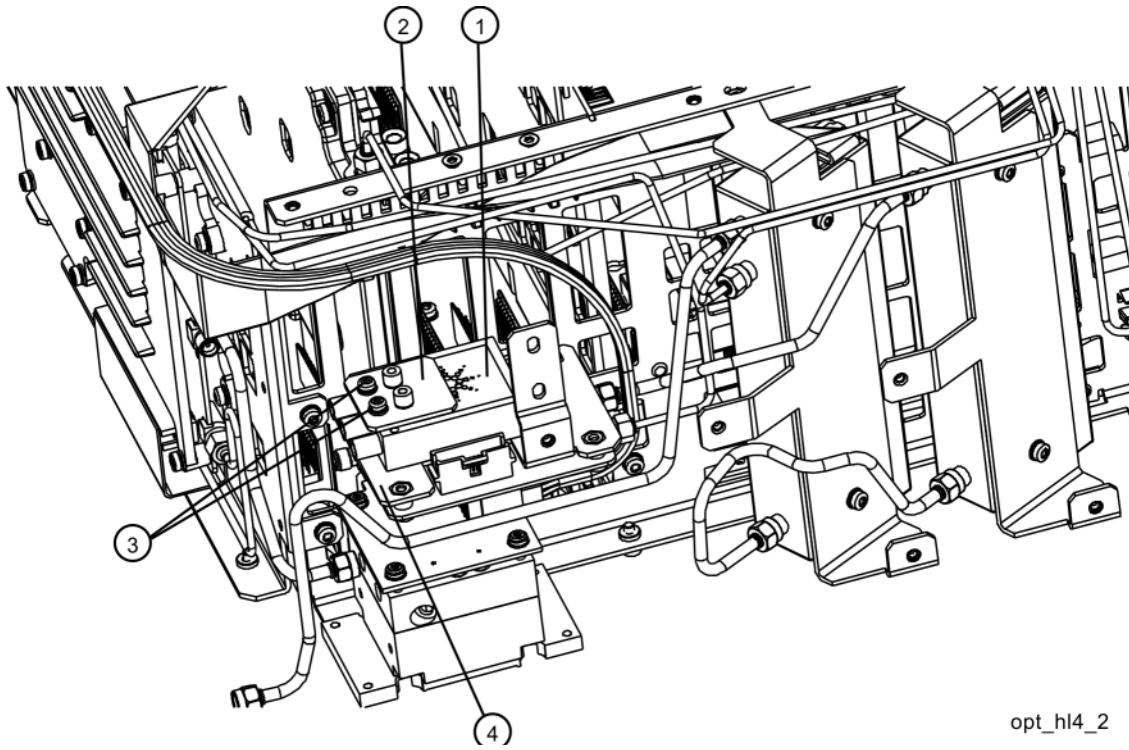
**Figure 14-24** Installing New Coax Cables



4. Install W3 between J2 of the A13 Front End Assembly and J2 of the A11 Low Band Switch. Torque to 10 inch-pounds.
5. Install W10 between the Type N input connector and the input of the A9 Input Attenuator. Torque to 10 inch-pounds.
6. Refer to **Figure 14-25**. Place one of the two coaxial switches **(1)** and the Switch 1 Bracket **(2)** onto the low band switch bracket. Mount the switch with the Keysight label facing up. Attach the bracket and switch to the low band switch bracket using two 0515-1992 screws **(3)** using the T-8 driver. Do not torque the screws at this time

opt\_hl4\_1

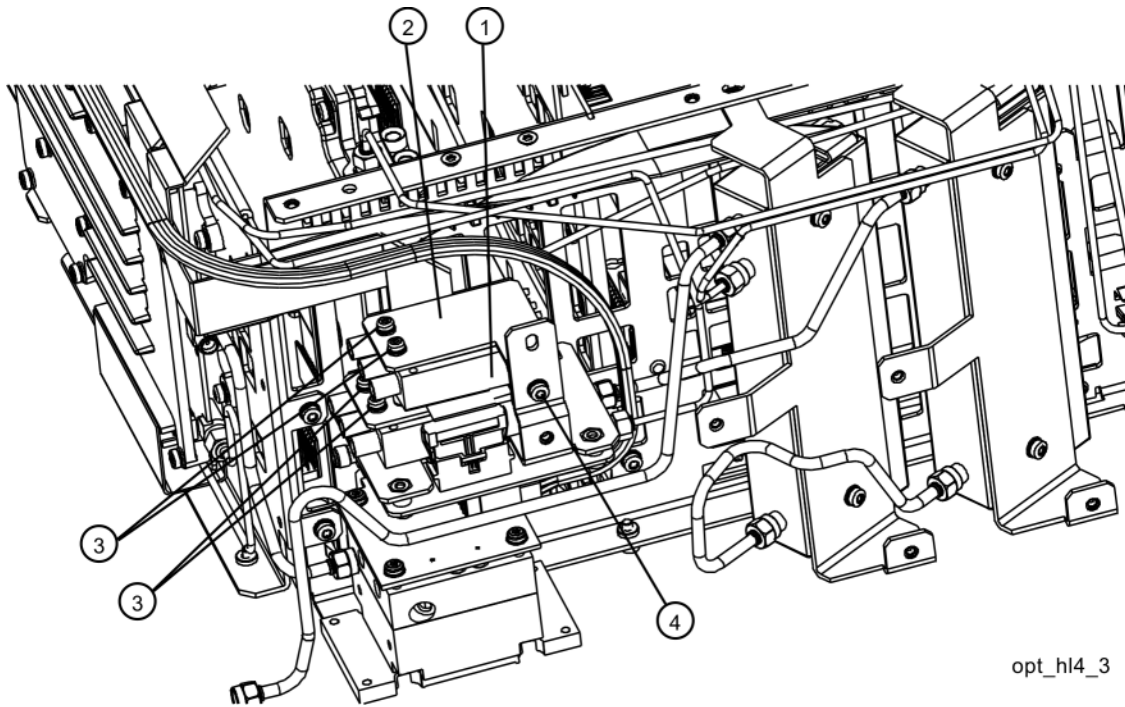
**Figure 14-25** Switch 1 Placement



opt\_hl4\_2

7. Refer to **Figure 14-26**. Place the second switch/bracket assembly **(1)/(2)** on the bracket previously installed. Assure Keysight label on switch is facing up. Attach the bracket and switch using two 0515-1992 screws **(3)** using the T-8 driver. Secure the bracket to the low band switch bracket with a single screw **(4)** using the T-10 driver. Do not torque.

**Figure 14-26** Switch 2 Placement



opt\_hl4\_3

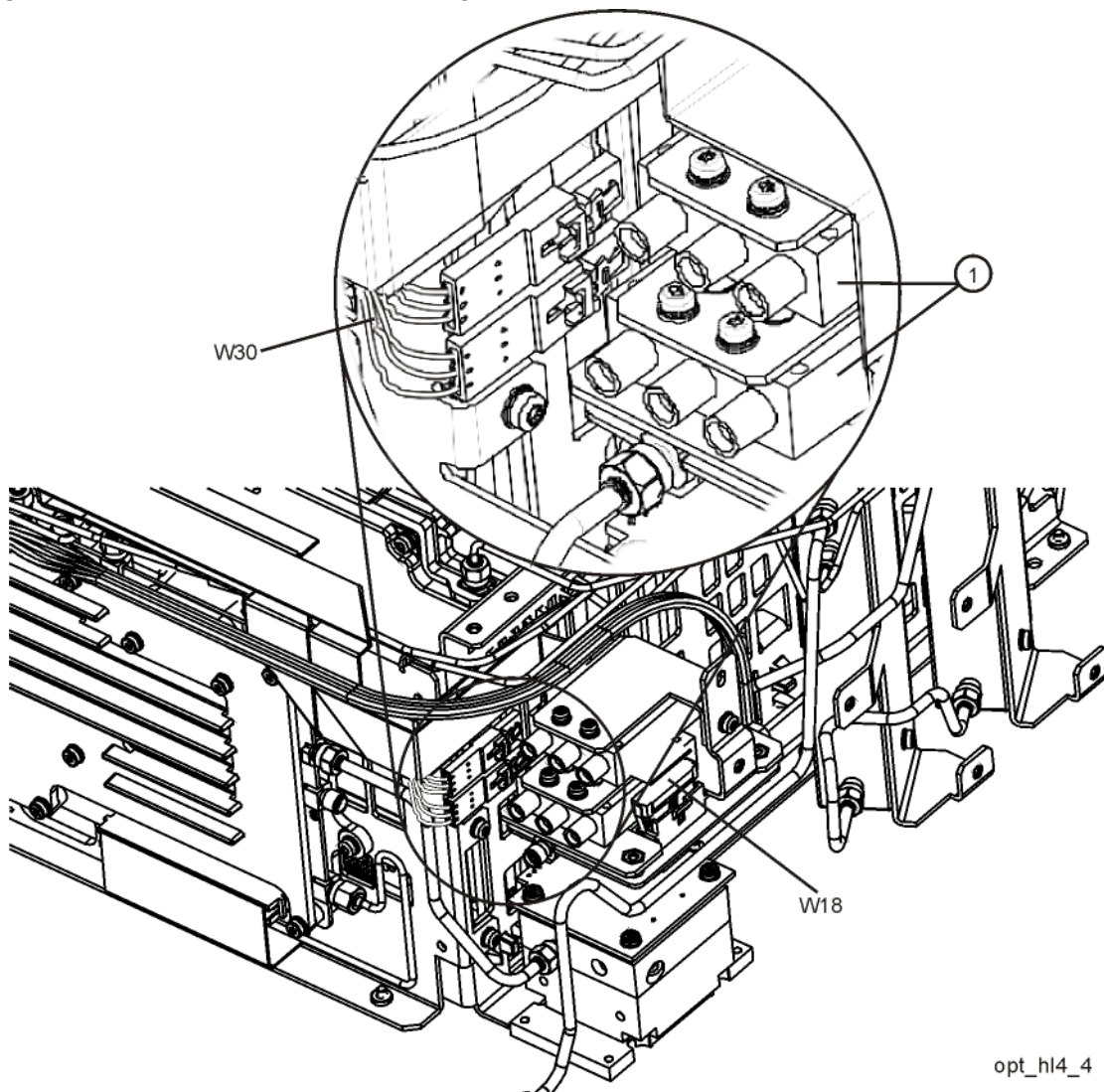
8. Align switches so they are parallel with the side of the instrument then torque the four screws **(3)** securing the switches to the brackets to 6 inch-pounds using the T-8 driver. Torque the screw **(4)** that secures the switch brackets together to 9 inch-pounds using the T-10 driver.

9. Refer to **Figure 14-27**. Connect the two wire harness connectors W30 to the switches (1). Once connected, position the connections along side the switches.

**NOTE** Even though the wire colors on W30 harness are different, it does not matter which one plugs into which switch.

---

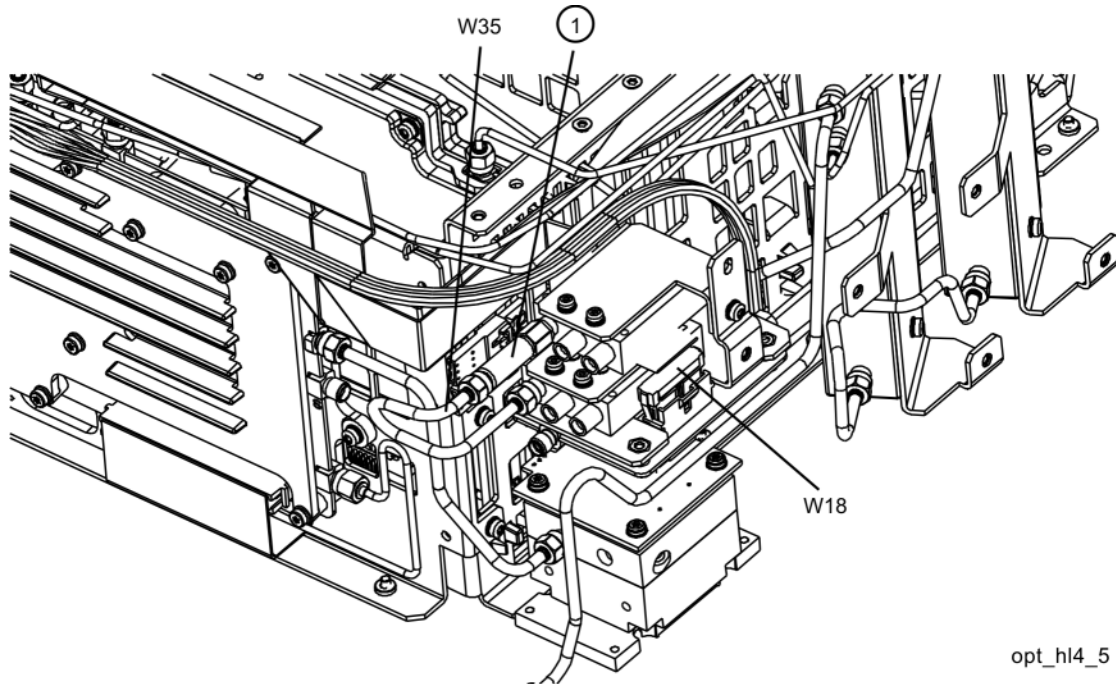
**Figure 14-27** Wire Harness Routing



10. Connect ribbon cable W18 to J4 of the A11 Low Band Switch.

11. Refer to **Figure 14-28**. Attach the coaxial fixed attenuator (1) Switch 2 port 1. Torque to 10 inch-lbs.

**Figure 14-28** Attenuator Installation

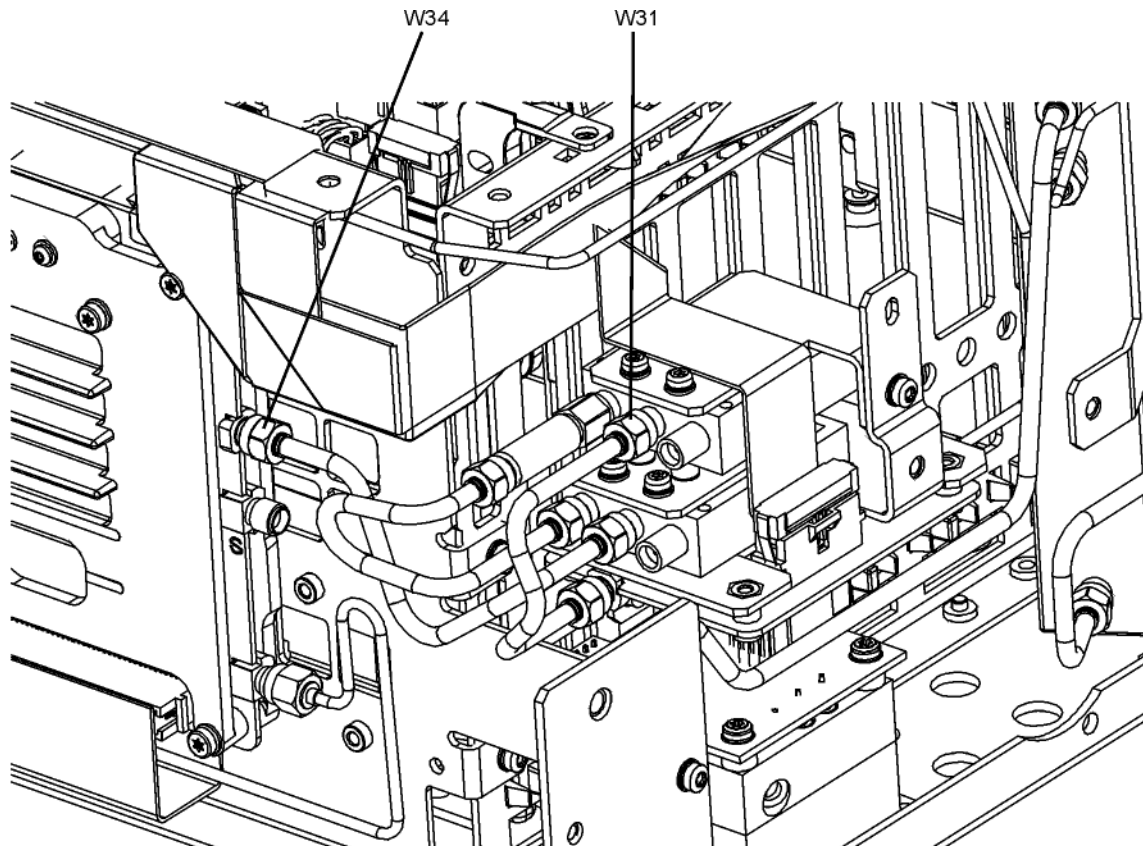


opt\_hl4\_5

12. Connect W35 semi-rigid coax cable between the coaxial fixed attenuator (1) and port 1 of Switch 1 (the lower switch). Torque to 10 inch-pounds.

13. Refer to **Figure 14-29**. Connect W34 semi-rigid coax cable between the center port of Switch 1 (the lower switch) and J9 of the A13 Front End Assembly. Torque to 10 inch-pounds.
14. Connect W31 semi-rigid coax cable between the center port of Switch 2 (the upper switch) and J3 of the A11 Low Band Switch. Torque to 10 inch-pounds.

**Figure 14-29** Install W34 and W31

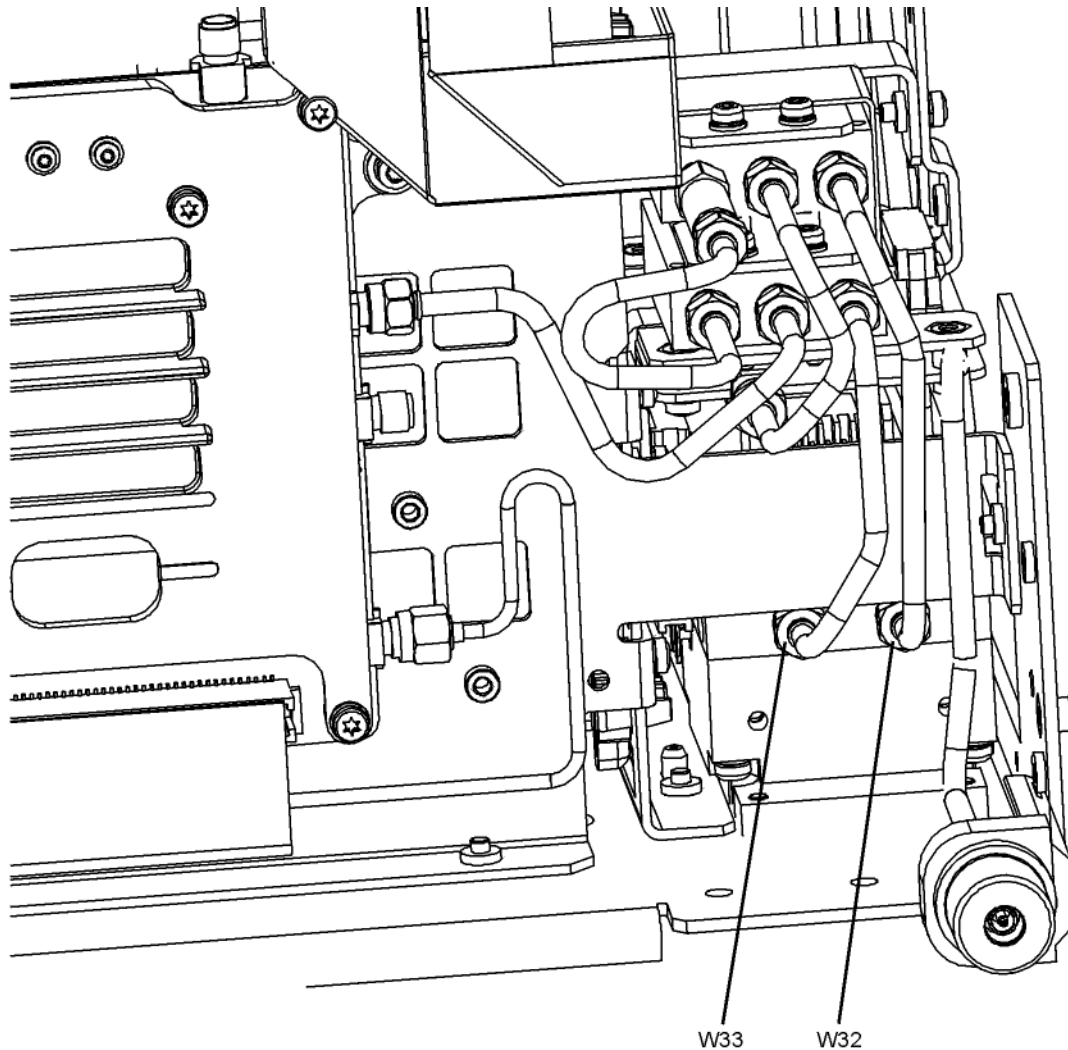


w34\_w31



15. Refer to **Figure 14-30**. Connect W33 semi-rigid coax cable between port 2 of Switch 1 (the lower switch) and the output of the A12 YTF Preselector. Torque the cable at the A12 end first to 10 inch-pounds and then torque the cable at the Switch 1 end to 10 inch-pounds.
16. Connect W32 semi-rigid coax cable between port 2 of Switch 2 (the upper switch) and the input of the A12 YTF Preselector. Torque the cable at the A12 end first to 10 inch-pounds and then torque the cable at the Switch 2 end to 10 inch-pounds.

**Figure 14-30** Install W33 and W32



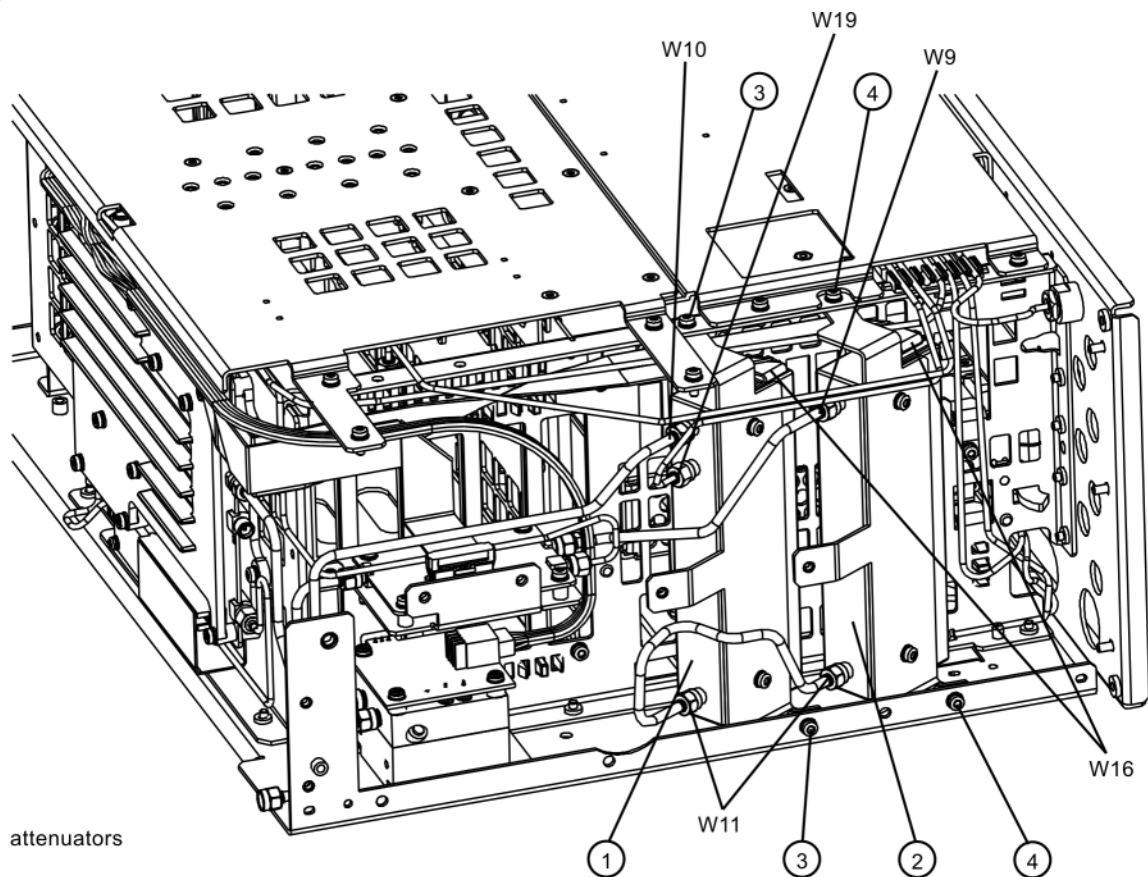
w33\_w32

## Attenuators

### Removal

1. Refer to **Figure 14-31**. To remove Attenuator A (1) or Attenuator B (2), remove the semi-rigid cables W9, W10, W11 and W19 attached to the attenuator using the 5/16 inch wrench.
2. Remove the W16 ribbon cable attached to the attenuator.
3. Remove the two screws (3) or (4) for each attenuator bracket to remove from the chassis using the T-10 driver.
4. Remove the two screws to separate the attenuator from the bracket.

Figure 14-31 Attenuators Removal



## Replacement

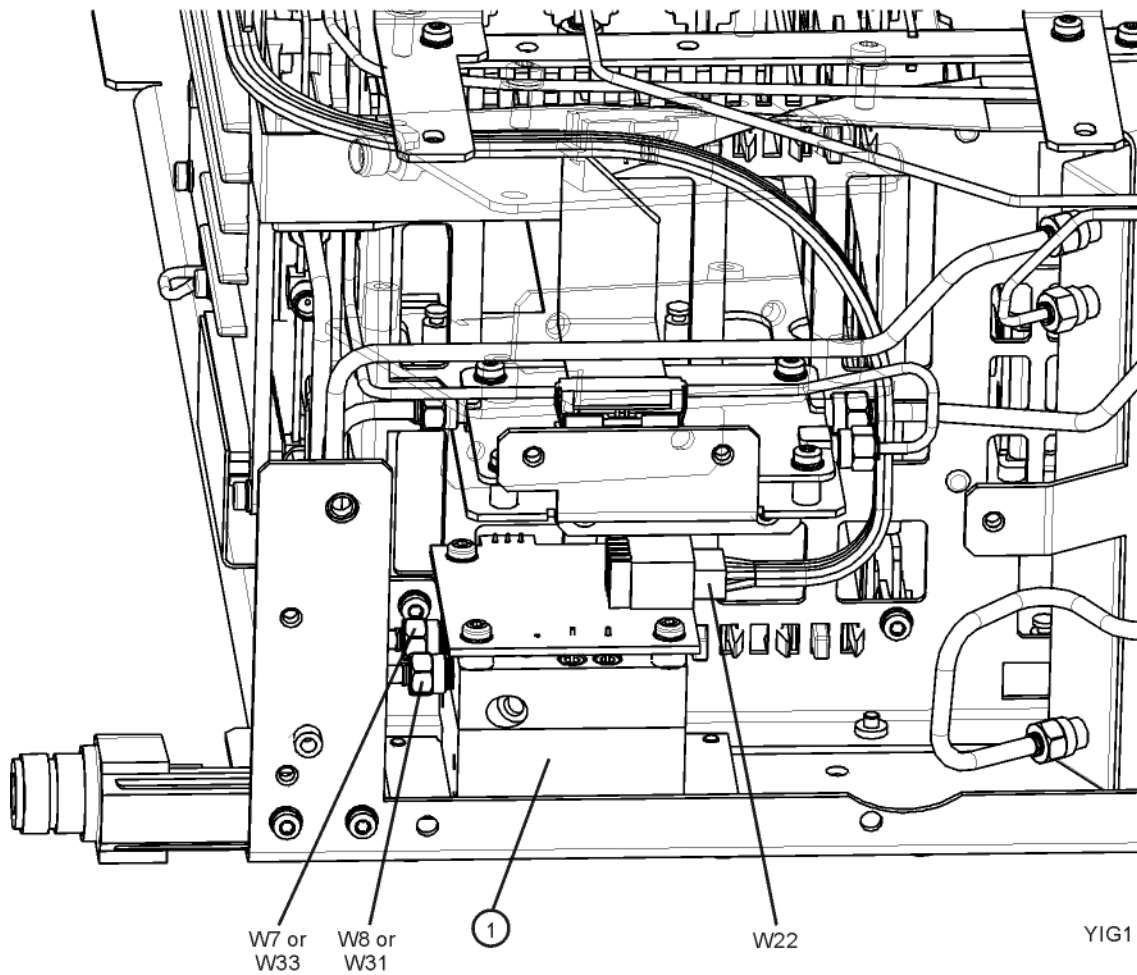
1. Refer to **Figure 14-31**. Position the attenuator in the bracket so that the ribbon connector end is “up”.
2. Replace the two screws that attach the attenuator to the bracket. Torque to 9 inch-pounds.
3. Position the attenuator and bracket into the chassis and attach with the two screws. Torque to 9 inch-pounds.
4. Replace the ribbon cable and semi-rigid cables W9, W10, W11 and W19 to the attenuator. Torque the semi-rigid cables to 10 inch-pounds.

## YTF Preselector

### Removal

1. Refer to **Figure 14-32**. Remove cables W7 and W8 from the YTF Preselector (1).

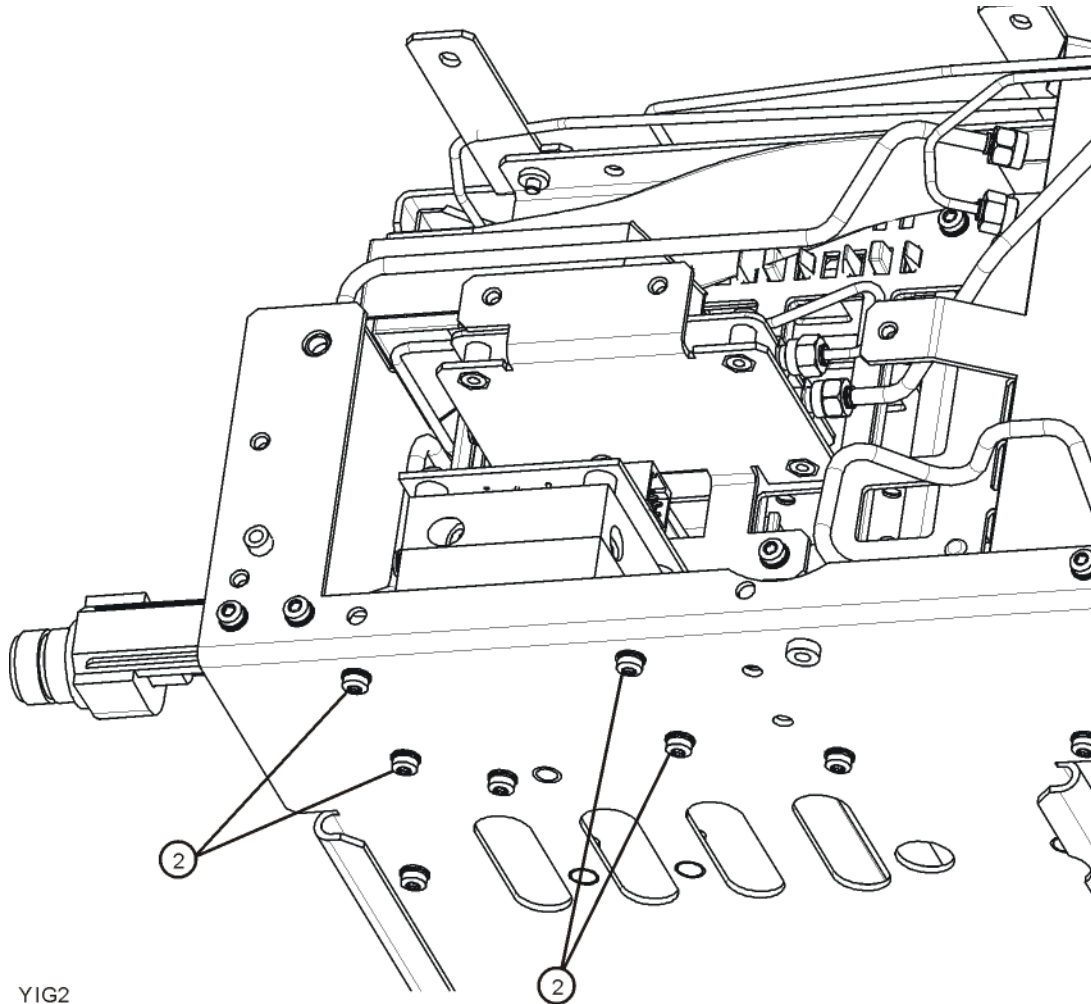
**Figure 14-32** YTF Preselector Removal



2. Remove the wire harness W22.

3. Refer to **Figure 14-33**. From the bottom of the instrument, remove the four screws (2). The YTF Preselector can now be removed from the chassis.

Figure 14-33 YTF Preselector Screws

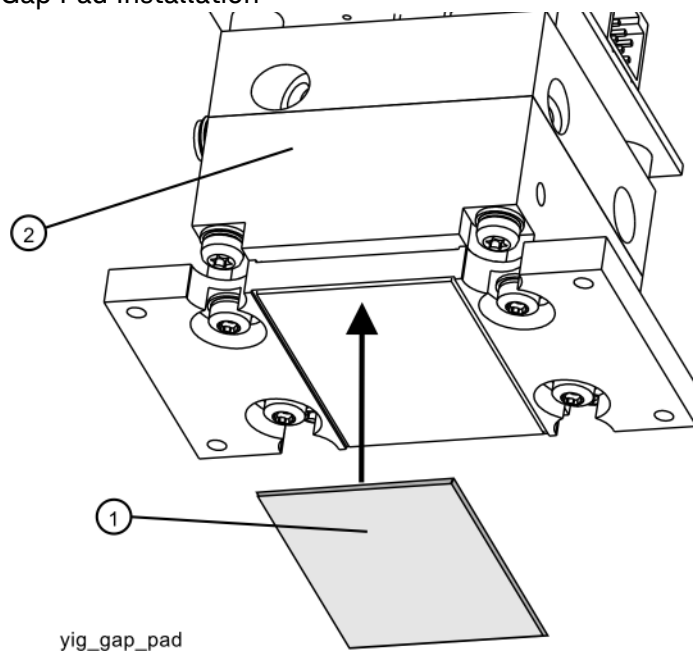


YIG2

## Replacement

1. Inspect the chassis where the YTF Preselector mounts and remove the gap pad if present (see [Figure 14-34](#), item (1)). The gap pad may remain attached to the faulty YTF Preselector.
2. Refer to [Figure 14-34](#). Install the replacement gap pad (1) into the recess in the base of the replacement YTF Preselector (2) Refer to [A12MP1](#) in [Chapter 13, "Replaceable Parts."](#) for the gap pad part number. Peel back one corner of the clear plastic backing on the pink side of the gap pad. Remove the blue backing from the other side of the gap pad. Install the gap pad as shown with the pink side exposed. Carefully peel off the clear plastic backing and smooth the gap pad into the recess.

**Figure 14-34** Gap Pad Installation



3. Refer to [Figure 14-33](#). Place the YTF Preselector into the chassis with the connectors toward the front of the instrument. Replace the four screws (2). Torque to 9 inch-pounds.
4. [Figure 14-32](#). Replace the cables W7 and W8. Torque to 10 inch-pounds.
5. Replace the wire harness W22.
6. Refer to [Figure 14-9](#). Position the chassis side, right onto the chassis and replace the thirteen screws. Torque to 9 inch-pounds.
7. Replace the front panel. Refer to the [Front Frame Assembly](#) replacement procedure.
8. Replace the top brace. Refer to the [Top Brace and Reference Bracket](#) replacement procedure.
9. Replace the instrument outer case. Refer to the Instrument Outer Casereplacement procedure.

## RF Front End Assembly

### Removal

1. Remove the instrument outer case. Refer to the Instrument Outer Caseremoval procedure.
2. Remove the instrument top brace. Refer to the Top Brace and Reference Bracket removal procedure.
3. Remove the front panel. Refer to the **Front Frame Assembly** removal procedure.
4. Refer to **Figure 14-35**. Using the 5/16 inch wrench, remove the cables W3, W4, W5, W7, W15 or W36, and W20 attached to the RF Front End Assembly **(1)**.

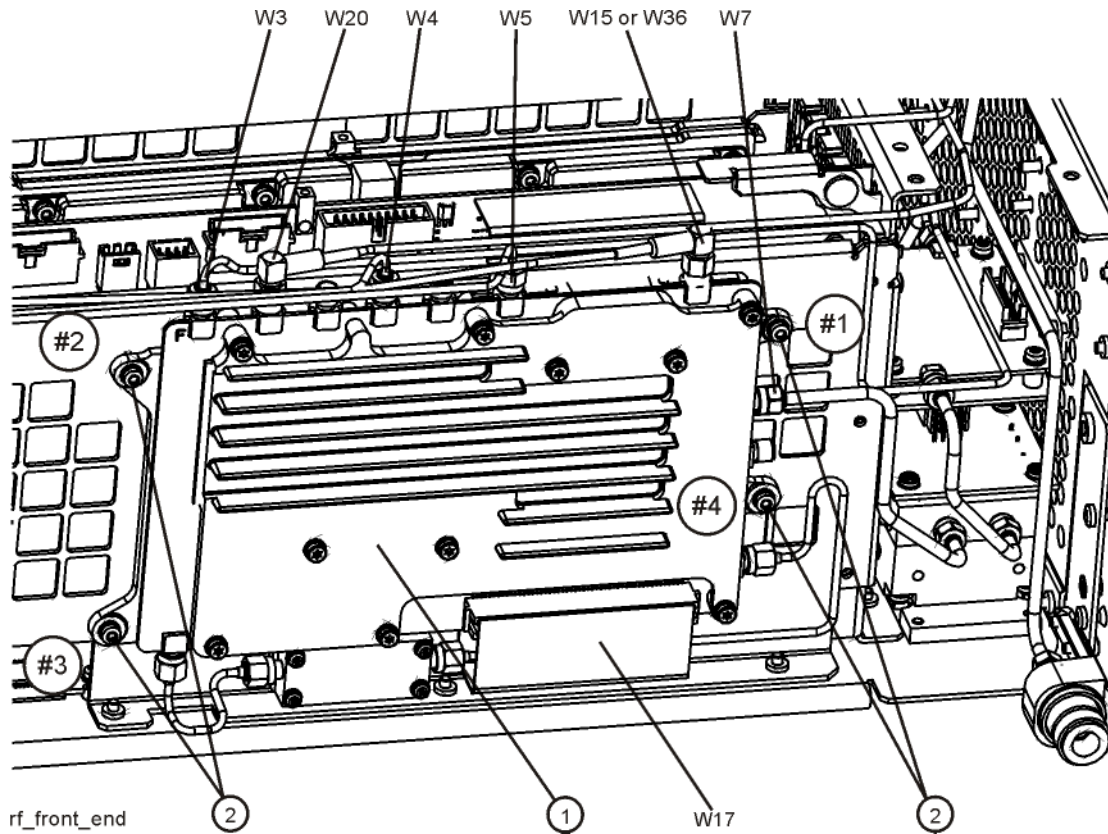
#### NOTE

W7 will not be present in instruments with Option 503.

---

5. Remove the ribbon cable W17 from the RF Front End Assembly.
6. Remove the four screws **(2)** using the T-10 driver. The RF Front End Assembly can now be removed from the chassis.

Figure 14-35 RF Front End Assembly Removal



## Replacement

1. Refer to [Figure 14-35](#). Place the RF Front End Assembly into the chassis. Replace the four screws (2). Torque to 9 inch-pounds in the sequence shown, starting with #1.
2. Reattach ribbon cable W17 to the RF Front End Assembly.
3. Reattach the cables W3, W4, W5, W7, W15 or W36, and W20 to the RF Front End Assembly (1). Torque the semi-rigid cables to 10 inch-pounds.

### NOTE

W7 will not be present in instruments with Option 503.

4. Replace the front panel. Refer to the [Front Frame Assembly](#) replacement procedure.
5. Replace the instrument top brace. Refer to the Top Brace and Reference Bracket replacement procedure.
6. Replace the instrument outer case. Refer to the Instrument Outer Casereplacement procedure.



## Front End Control Assembly

### Removal

1. Remove the instrument outer case. Refer to the Instrument Outer Caseremoval procedure.
2. Remove the instrument top brace. Refer to the Top Brace and Reference Bracket removal procedure.
3. Refer to **Figure 14-36**. Remove the ribbon cables W16, W17, and W18 and the wire harness W22 from the Front End Control assembly **(1)**.

**NOTE** W22 will not be present in instruments with Option 503.

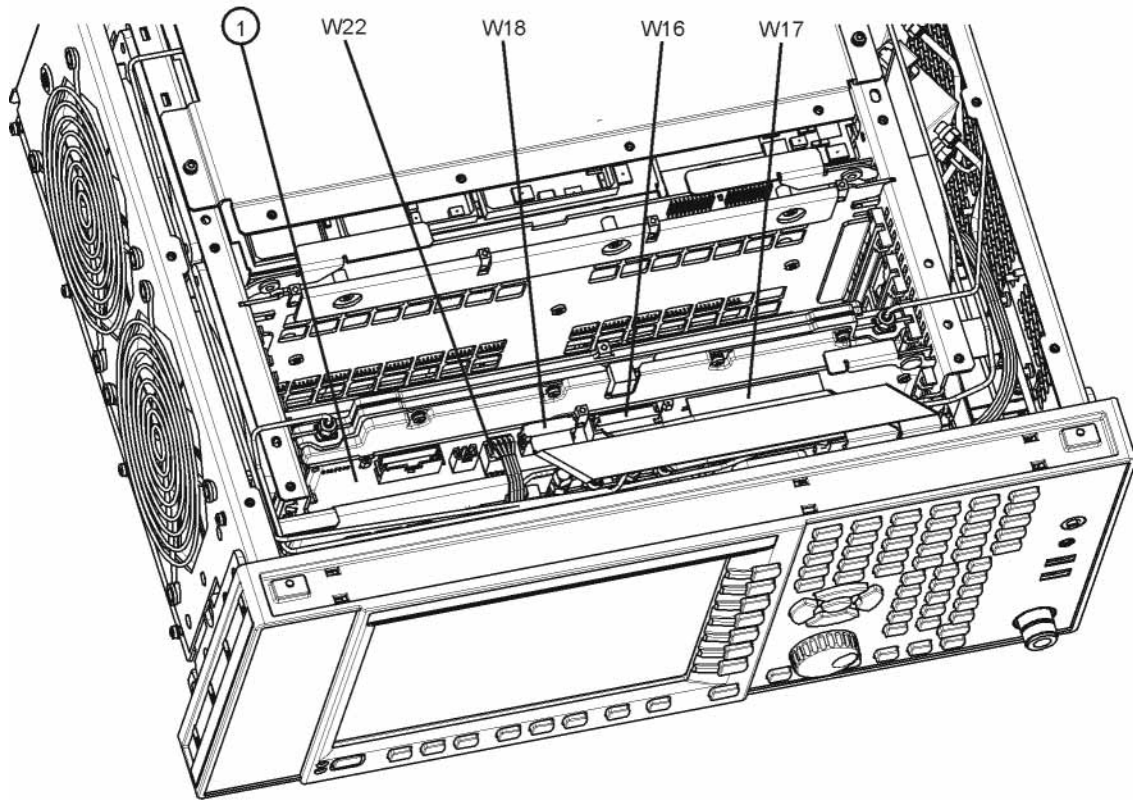
---

**NOTE** Instruments with Options DP2, MPB, B40, CR3, or CRP will have the Enhanced Front End Control Assembly which will have additional cables as shown in **Figure 14-37**.

---

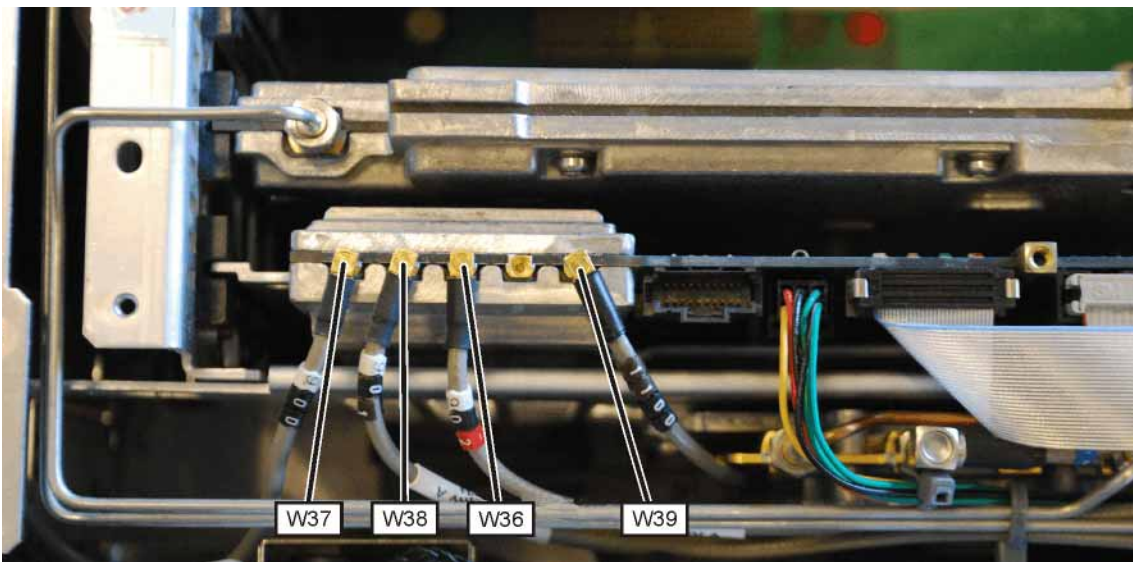
4. The Front End Control assembly can now be unplugged from the motherboard by leveraging up on the ejector and lifting the board up on the other side.

Figure 14-36 Front End Control Assembly Removal



front\_end\_control

Figure 14-37 Enhanced Front End Control Assembly Cables



## Replacement

1. Refer to **Figure 14-36**. Install the Front End Control assembly into slot 6 in the chassis securing with the ejector.
2. Reattach the ribbon cables W16, W17, and W18 and the wire harness W22 to the Front End Control assembly **(1)**. If the instrument has the Enhanced Front End Control Assembly, reattach the additional cables as shown in **Figure 14-37**.

---

**NOTE**

W22 will not be present in instruments with Option 503.

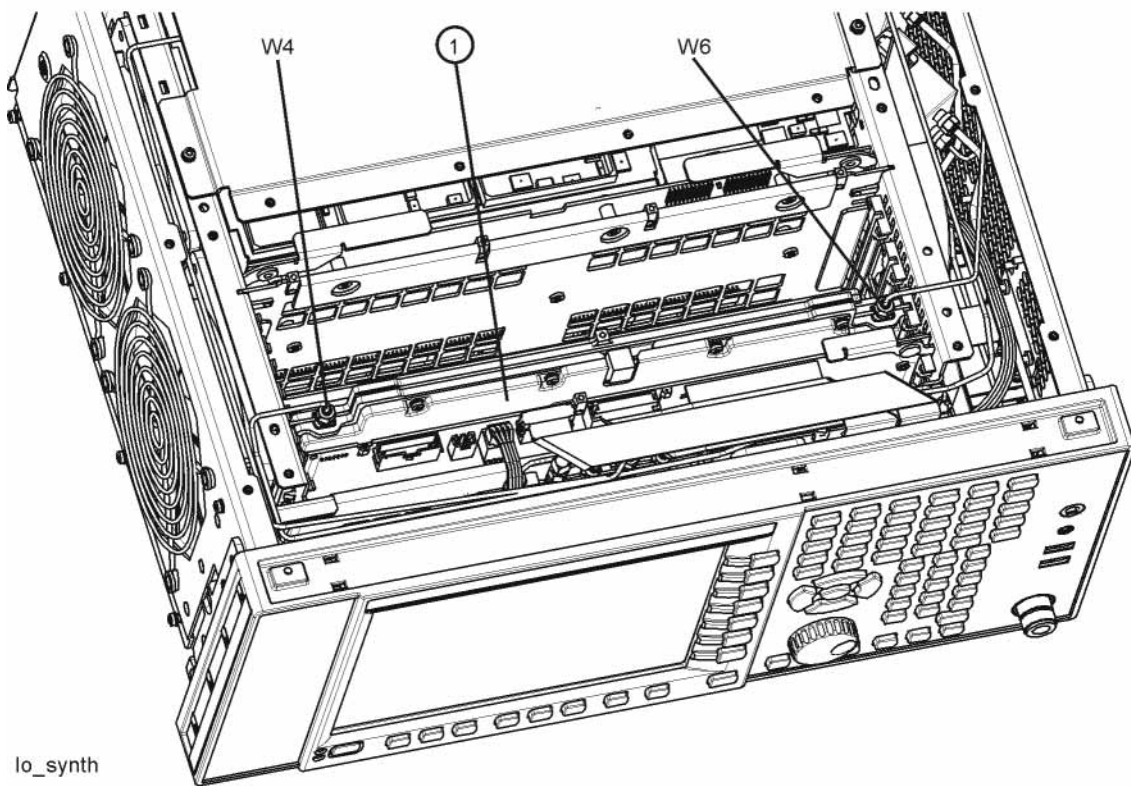
- 
3. Replace the instrument top brace. Refer to the Top Brace and Reference Bracket replacement procedure.
  4. Replace the instrument outer case. Refer to the Instrument Outer Casereplacement procedure.

## L.O. Synthesizer Assembly

### Removal

1. Remove the instrument outer case. Refer to the Instrument Outer Caseremoval procedure.
2. Remove the instrument top brace. Refer to the Top Brace and Reference Bracket removal procedure.
3. Refer to **Figure 14-38**. Remove the cables W4 and W6 from the L.O. Synthesizer assembly (**1**) using the 5/16 inch wrench.
4. The L.O. Synthesizer assembly can now be unplugged from the motherboard by pulling up on the board and lifted out of the chassis.

Figure 14-38 L.O. Synthesizer Assembly Removal



### Replacement

1. Refer to **Figure 14-38**. Install the L.O. Synthesizer assembly into slot 5 in the chassis and press down to plug it into the motherboard.
2. Reattach the cables W4 and W6 to the L.O. Synthesizer assembly (**1**). Torque to 10 inch-pounds.

- 3.** Replace the instrument top brace. Refer to the Top Brace and Reference Bracket replacement procedure.
- 4.** Replace the instrument outer case. Refer to the Instrument Outer Casereplacement procedure.

## Rear Panel

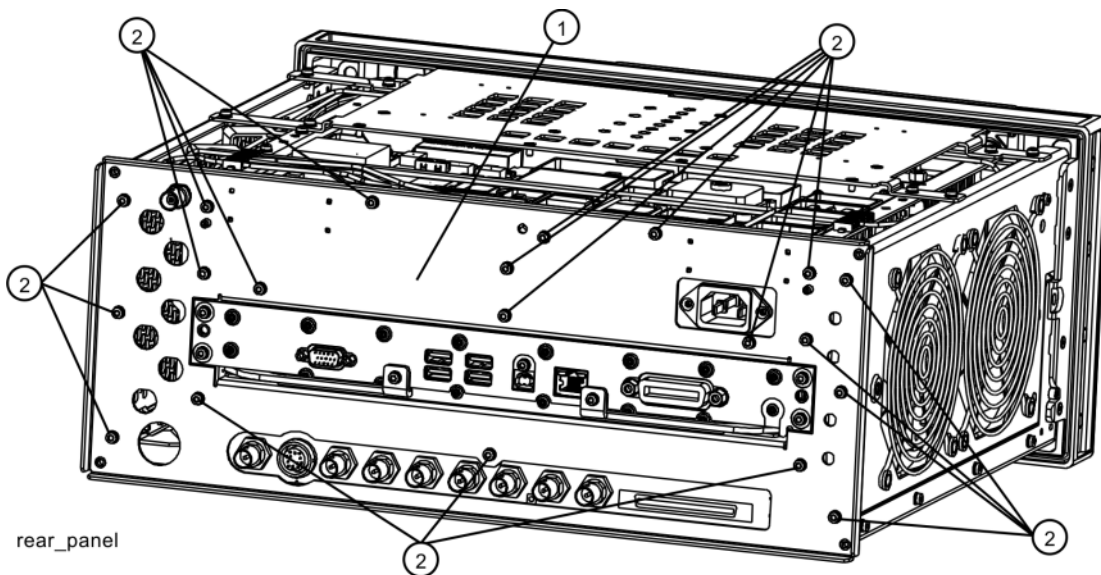
### Removal

1. Remove the instrument outer case. Refer to the Instrument Outer Caseremoval procedure.
2. Refer to **Figure 14-39**. Using the T-10 driver, remove the twenty screws (2) attaching the rear panel (1) to the chassis and to the reference bracket. The rear panel can now be removed.
3. Refer to **“Reference Assembly” on page 487**. Remove W23 cable from the A16 Reference Assembly (1) at A16J704.

#### NOTE

If the rear panel is being replaced with a new rear panel, remove W23 at the rear panel using a 9/16-inch nut driver. Instruments with Option CR3 or CRP will have an additional cable W39 that is attached to the rear panel.

Figure 14-39 Rear Panel Removal



### Replacement

1. Reattach W23 cable to A16J704 or to the rear panel depending on how you removed it.
2. Refer to **Figure 14-39**. Place the rear panel (1) into position in the chassis. Replace the twenty screws (2) to attach the rear panel to the chassis. Torque to 9 inch-pounds.
3. Replace the instrument outer case. Refer to the Instrument Outer Casereplacement procedure.

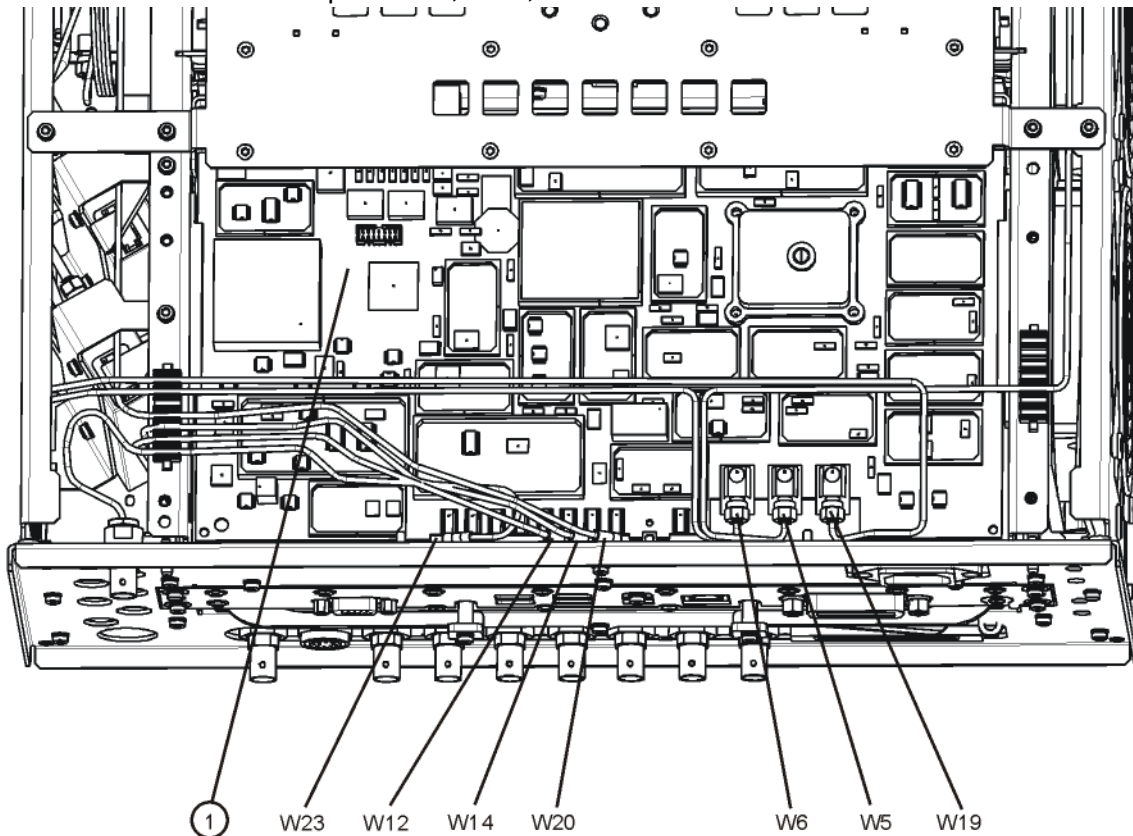
## Reference Assembly

### Removal

(Serial Prefix < MY/SG/US5233  
without Option B85, B1A, or B1X)

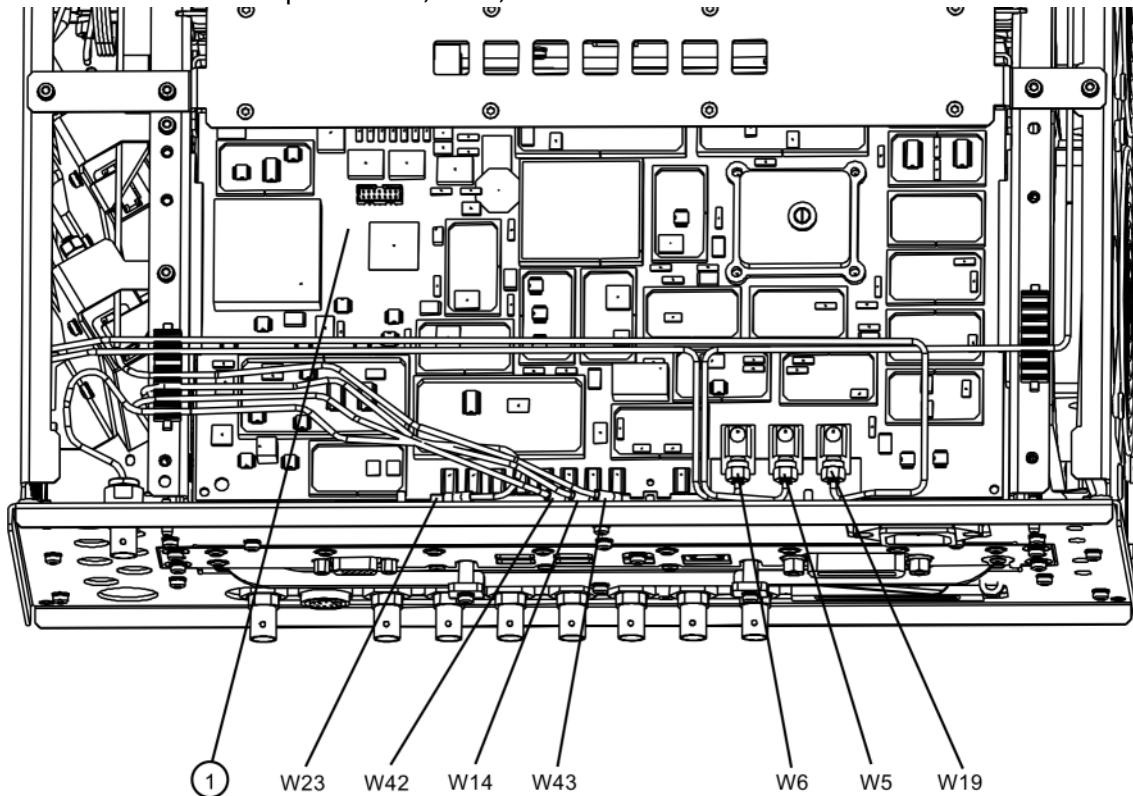
1. Remove the instrument outer case. Refer to the Instrument Outer Caseremoval procedure.
2. Remove the reference bracket. Refer to the Top Brace and Reference Bracket removal procedure.
3. Remove the rear panel. Refer to the Rear Panelremoval procedure.
4. For standard instruments, refer to **Figure 14-40**. Remove cables W5, W6, W12, W14, W19, W20, W23, and W25 (Option BBA only) from the reference assembly (1). Use the 5/16 inch wrench where necessary.

**Figure 14-40** Reference Board Cables - Serial Prefix < MY/SG/US5233  
without Option B40, MPB, or DP2



5. For instruments with Option B40, MPB, or DP2, refer to **Figure 14-41**. Remove cables W5, W6, W14, W19, W23, W42, W43, and W25 (Option BBA only) from the reference assembly (1). Use the 5/16 inch wrench where necessary.

**Figure 14-41** Reference Board Cables - Serial Prefix < MY/SG/US5233 with Options B40, MPB, DP2



reference\_cables\_option

6. The reference assembly can be removed from the chassis by leveraging up on the ejector and pulling the board out on the other side.

## Removal

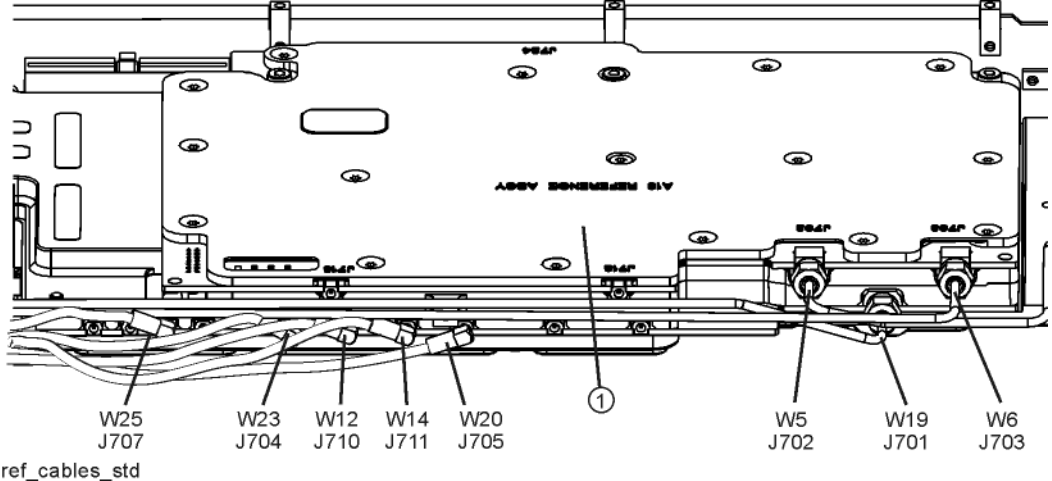
(Serial Prefix  $\geq$  MY/SG/US5233

and any with Option B85, B1A, or B1X)

1. Remove the instrument outer case. Refer to the Instrument Outer Caseremoval procedure.
2. Remove the four flathead screws securing the top brace to the Reference Assembly.
3. Remove the rear panel. Refer to the Rear Panelremoval procedure.
4. For standard instruments, refer to **Figure 14-42**. Remove cables W5, W6, W12, W14, W19, W20, W23, and W25 (Option BBA only) from the reference assembly (1). Use the 5/16 inch wrench where necessary.

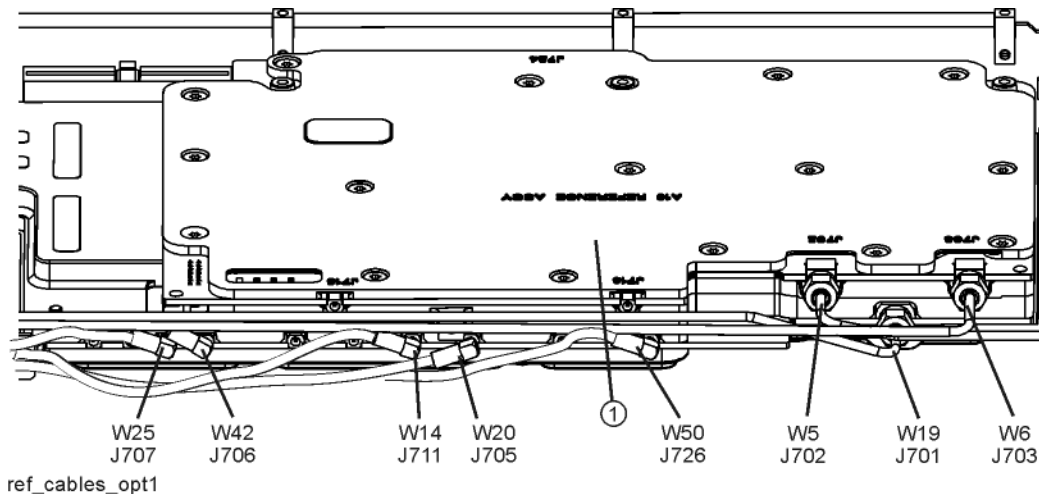


**Figure 14-42** Reference Board Cables - Serial Prefix > MY/SG/US5233  
without Option B40, MPB, or DP2



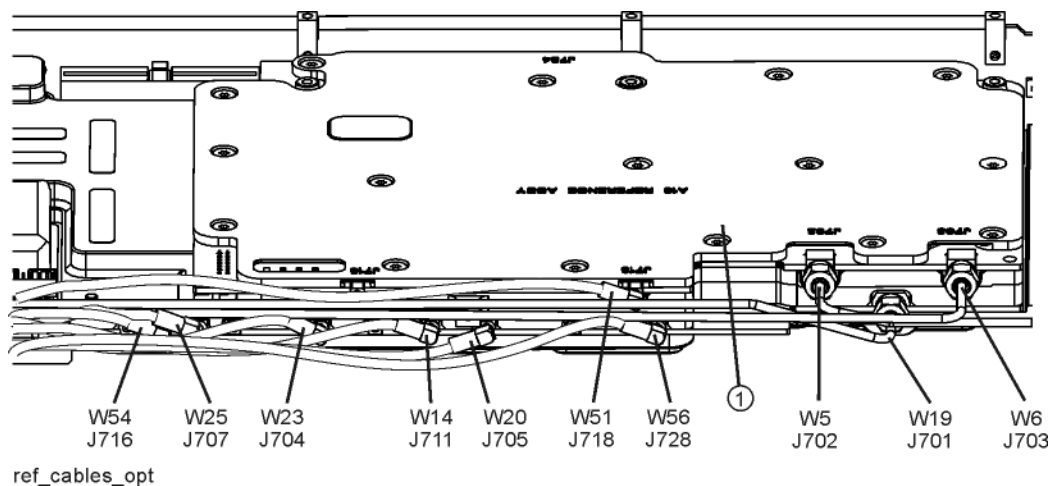
5. For instruments with Option B40, MPB, or DP2 but without Option B85, B1A, or B1X, refer to **Figure 14-43**. Remove cables W5, W6, W14, W19, W20, W42, W50, and W25 (Option BBA only) from the reference assembly (1). Use the 5/16 inch wrench where necessary.

**Figure 14-43** Reference Board Cables - Serial Prefix > MY/SG/US5233 with Option B40, MPB, or DP2 and without Option B85, B1A, or B1X



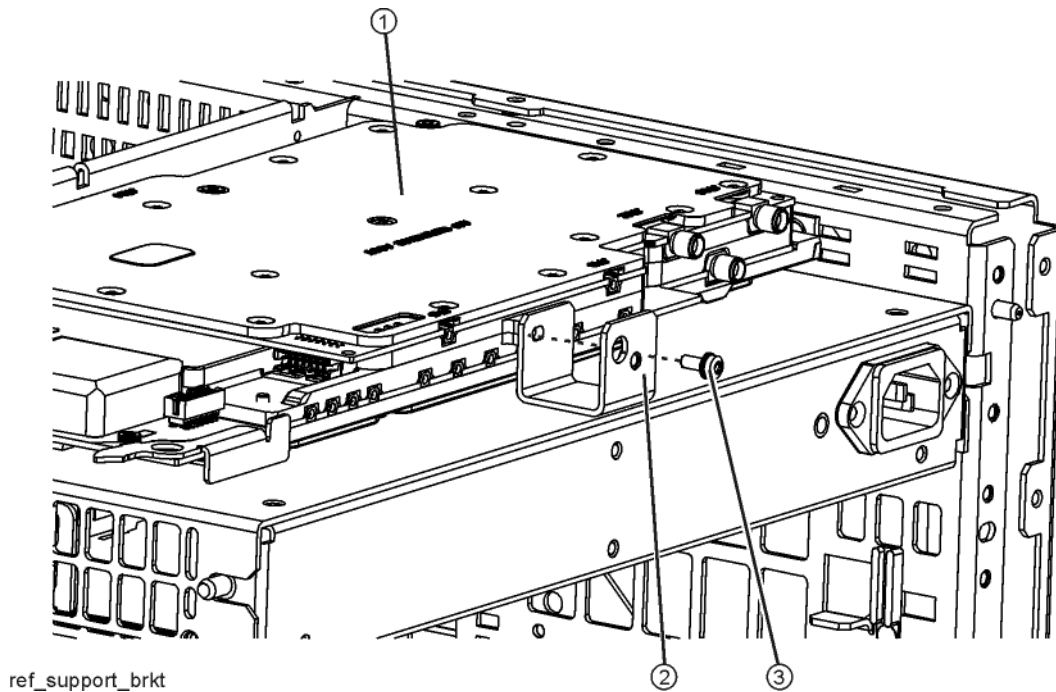
6. For instruments with Option B85, B1A, or B1X, refer to **Figure 14-44**. Remove cables W5, W6, W14, W19, W20, W23, W25 (Option BBA only), W51, W54, and W56 from the reference assembly (1). Use the 5/16 inch wrench where necessary.

**Figure 14-44** Reference Board Cables - Serial Prefix > MY/SG/US5233 with Option B85, B1A, B1X



7. Refer to **Figure 14-45**. Remove the reference support bracket (2) by removing the pan-head screw (3) (0515-0372) securing the bracket to the Reference assembly (1). **Figure 14-43**.

**Figure 14-45** Reference Support Bracket Removal



8. The reference assembly can be removed from the chassis by leveraging up on the ejector and pulling the board out on the other side.

## Replacement

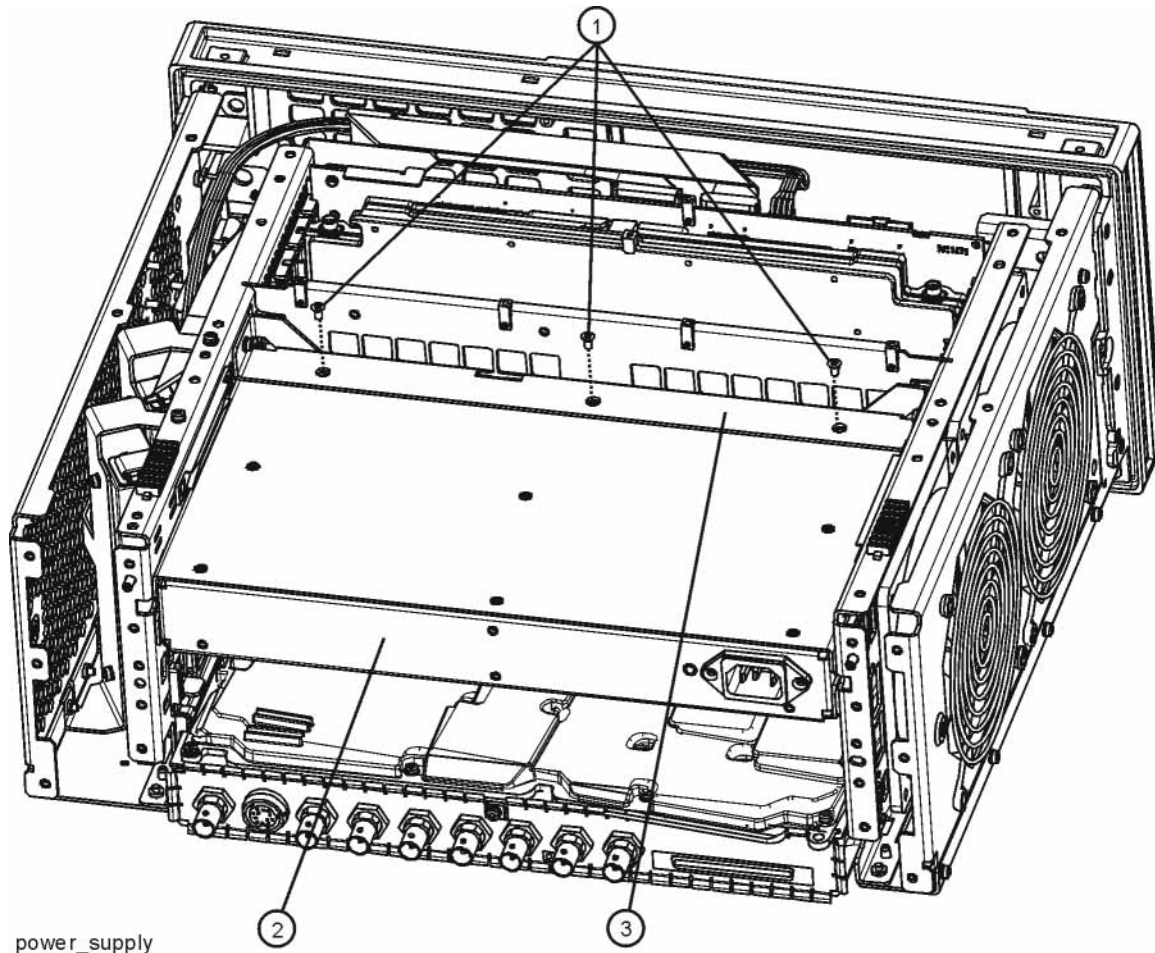
1. Slide the reference assembly into the slot at the rear of the instrument and push on the assembly to mate the connectors to the midplane assembly. Secure with the ejector.
2. If the serial prefix is  $\geq$  MY/SG/US5233 or Option B85, B1A, or B1X is installed, refer to [Figure 14-45](#). Secure the reference support bracket (2) to the Reference assembly (1) using a pan-head screw (3) (0515-0372).
3. Refer to [Figure 14-40](#), [Figure 14-41](#), [Figure 14-42](#), [Figure 14-43](#), or [Figure 14-44](#) as appropriate. Reconnect the cables to the correct locations. Torque the semi-rigid coax cables to 10 inch-pounds.
4. Replace the rear panel. Refer to the Rear Panel replacement procedure.
5. Replace the reference bracket (serial prefix  $<$  MY/SG/US5233 or secure the A16 Reference assembly to the top brace (serial prefix  $\geq$  MY/SG/US5233). Refer to the Top Brace and Reference Bracket replacement procedure.
6. Replace the instrument outer case. Refer to the Instrument Outer Case replacement procedure.

## Power Supply Assembly

### Removal

1. Remove the instrument outer case. Refer to the Instrument Outer Case removal procedure.
2. Remove the rear panel. Refer to the Rear Panel removal procedure.
3. Remove the top brace and reference bracket. Refer to the Top Brace and Reference Bracket removal procedure.
4. Remove the reference assembly. Refer to the Reference Assembly removal procedure.
5. Remove the CPU assembly. Refer to the CPU Assembly removal procedure.
6. Refer to **Figure 14-46**. Remove the three screws (1) attaching the power supply (2) to the power supply bracket (3).
7. The power supply assembly can be removed from the chassis by pulling straight out the back.

Figure 14-46 Power Supply Assembly Removal



## Replacement

1. Slide the power supply assembly into the slot at the rear of the instrument and push on the assembly to mate the connectors to the midplane assembly.
2. Refer to **Figure 14-46**. Replace the three screws (1) through the power supply bracket (3) and into the power supply (2). Torque to 9 inch-pounds.
3. Replace the CPU assembly. Refer to the CPU Assembly replacement procedure.
4. Replace the reference assembly. Refer to the Reference Assembly replacement procedure.
5. Replace the top brace and reference bracket. Refer to the Top Brace and Reference Bracket replacement procedure.
6. Replace the rear panel. Refer to the Rear Panel replacement procedure.

- 7. Replace the instrument outer case. Refer to the Instrument Outer Casereplacement procedure.**

## CPU Assembly

### Removal

Depending on the vintage of your instrument, the CPU assembly will look either like [Figure 14-47](#) or [Figure 14-48](#).

Figure 14-47 Current CPU Assembly - Rear Panel View



Figure 14-48 Old CPU Assembly - Rear Panel View



1. Refer to [Figure 14-49](#) or [Figure 14-50](#). Remove the six screws (1) attaching the CPU assembly to the chassis.
2. The CPU assembly can be removed from the chassis by pulling straight out the back. Use the two ejectors to pull the CPU assembly out from the chassis.

#### NOTE

If the A4BT1 CPU board battery was changed, refer to [Chapter 15](#), [“Post-Repair Procedures.”](#) for setup instructions.

Figure 14-49 New CPU Assembly Removal

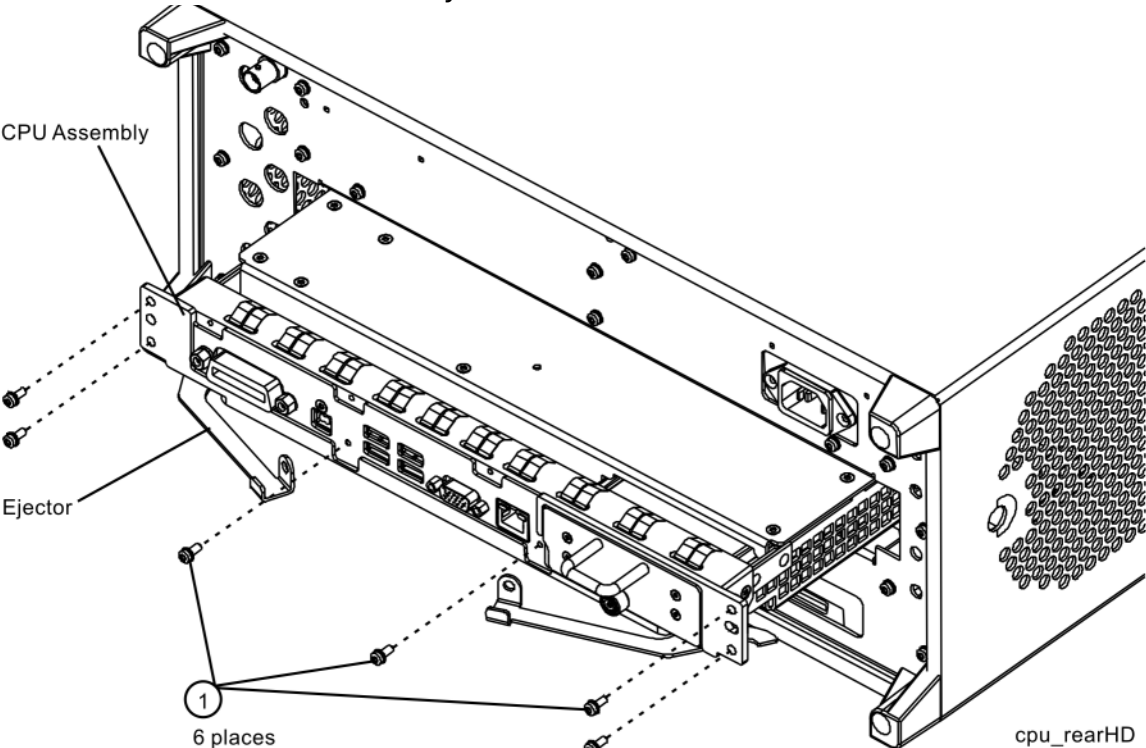
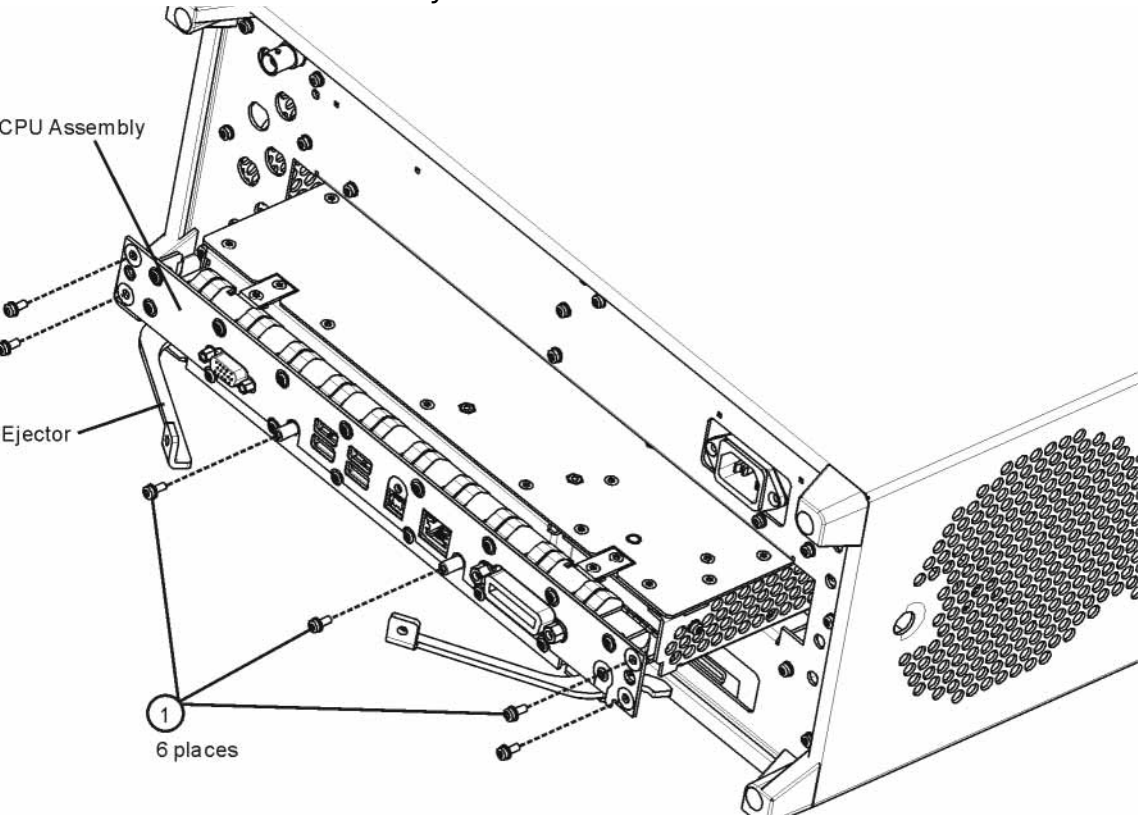


Figure 14-50 Old CPU Assembly Removal





## Replacement

1. Slide the CPU assembly into the slot at the rear of the instrument and push on the assembly to mate the connectors to the midplane assembly. Secure the board with the ejectors.
2. Refer to [Figure 14-49](#) or [Figure 14-50](#). Replace the six screws **(1)** that attach the CPU assembly to the chassis. Torque to 9 inch-pounds.

## Disk Drive

There are two different types of disk drive installations that have been used in the X-Series Signal Analyzers. Originally the drive was located inside of the A4 CPU assembly, which would need to be removed and opened up in order to replace the drive. However, starting with serial number MY/SG/US49100000 the disk drive has been relocated such that it can be removed through the rear panel of the instrument. Of course, instruments that originally had their disk drive located inside of the A4 CPU assembly could have been upgraded with Option PC2 and would now have a rear panel removable disk drive as well.

If the A5 Disk Drive is being replaced on an instrument with a serial number greater than MY/SG/US49100000, or has had an Option PC2 upgrade, follow the procedure below under the heading **“Rear Panel Removable Disk Drive”**. If the instrument has a serial number prior to MY/SG/US49100000, and has not had an Option PC2 upgrade, follow the procedure below under the heading **“Internally Mounted Disk Drive”** for instructions on replacing the A5 Disk Drive.

---

**NOTE** Refer to **Figure 14-47** and **Figure 14-48** for illustrations of the difference between the new CPU and old CPU assemblies.

---

**CAUTION** Electrostatic discharge (ESD) can damage or destroy electronic components. All work on electronic assemblies should be performed at a static-safe workstation. Refer to the documentation that pertains to your instrument for information about static-safe workstations and ordering static-safe accessories.

---

### Rear Panel Removable Disk Drive

#### Drive Removal and Replacement

1. Before replacing the A5 disk drive it is highly recommended that the factory calibration data be backed up to an external drive if at all possible. If this data is not backed up prior to replacing the disk drive all instrument adjustments and performance verification tests will need to be run after the drive is replaced.

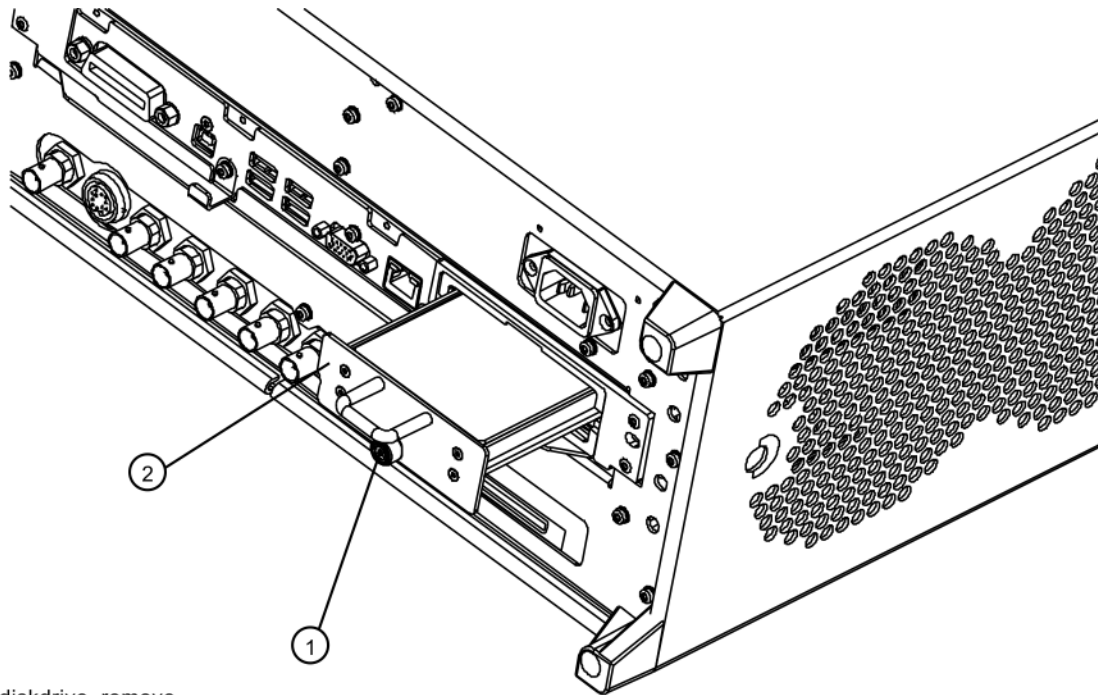
For information on how to backup this data see the **“Calibration Data Backup and Restore”** section in **Chapter 15, “Post-Repair Procedures.”** of this manual.

If this data cannot be backed up because the instrument will not fully boot, go ahead and change the A5 Disk Drive and perform all adjustments listed in **Chapter 15, “Post-Repair Procedures.”** for the A5 assembly.

2. Turn the instrument off and remove the AC power cord.

3. Refer to **Figure 14-51**. Locate and remove the existing disk drive carrier assembly (2) from the instrument by loosening the rear panel screw (1).

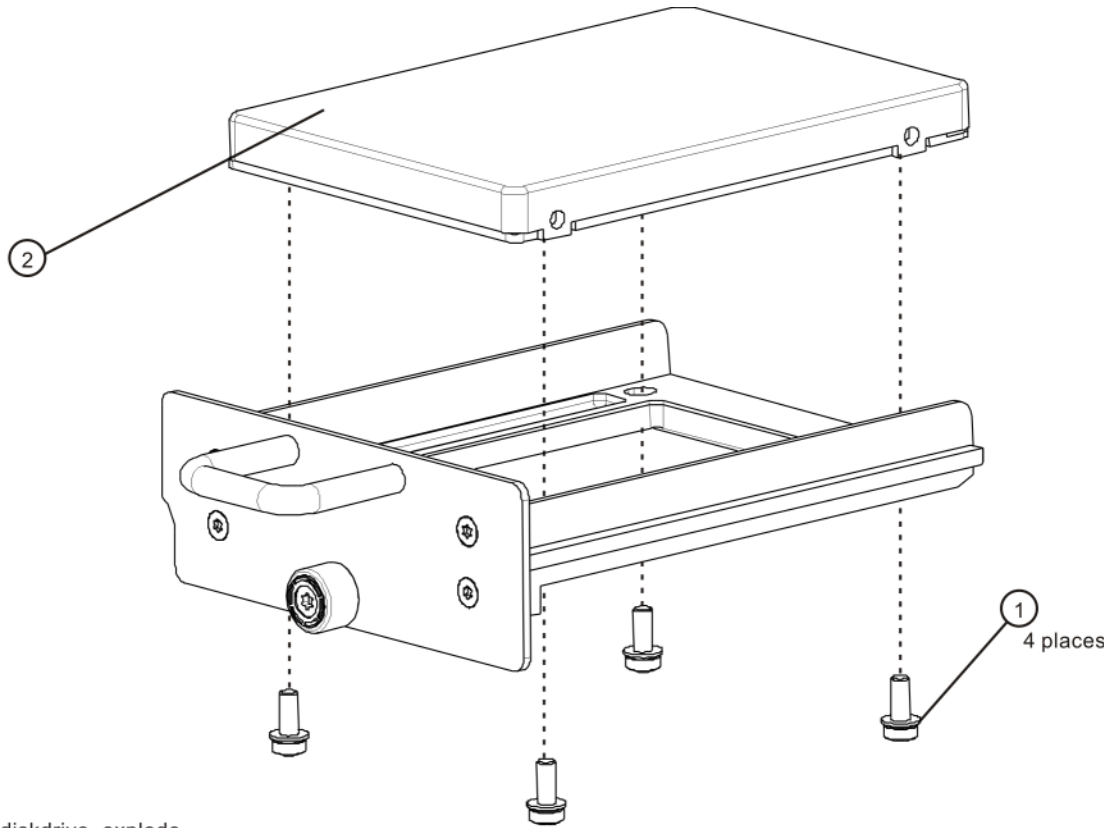
**Figure 14-51** Removing the Disk Drive Carrier Assembly



diskdrive\_remove

4. Refer to **Figure 14-52**. Remove the 4 machine screws (1) from the disk drive carrier assembly that secure the drive (2).

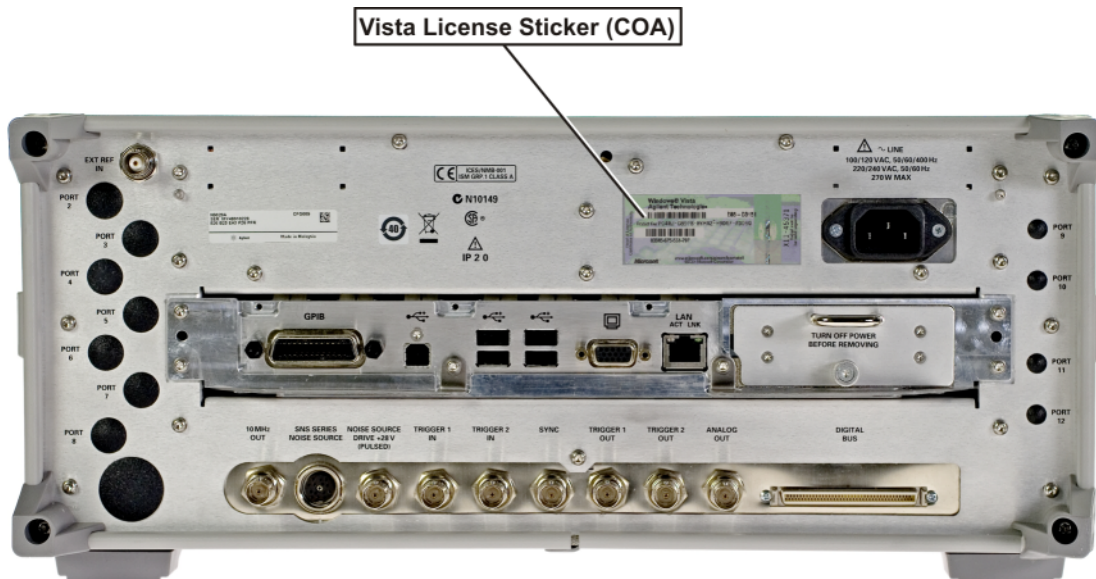
**Figure 14-52** Disk Drive Screws



diskdrive\_explode

5. Remove the disk drive (2) from the carrier assembly.
6. Place the new disk drive onto the carrier assembly and attach with the 4 machine screws (1). Torque to 9 in-lbs.
7. Refer to [Figure 14-51](#). Replace the disk drive carrier assembly (2) into the instrument and tighten the screw to 9 in-lbs.
8. Locate the Windows Vista License Sticker from the kit and apply the sticker to the rear of the instrument as shown in [Figure 14-53](#), covering the existing license sticker.

**Figure 14-53** Windows License Sticker Rear Panel Location



**NOTE**

While the replacement disk drive has the Windows XP operating system loaded onto it, the license that accompanies it in this kit is for Windows Vista. This is being done within the scope of our license agreement with Microsoft and is necessary at this time, as the instrument applications software is not supported or qualified with any operating system other than Windows XP.

- 
9. Refer to [Chapter 15, "Post-Repair Procedures."](#) and perform all of the specified tasks for replacing the A5 Disk Drive assembly.

## Internally Mounted Disk Drive

### Drive Removal and Replacement

1. Before replacing the A5 disk drive it is highly recommended that the factory calibration data be backed up to an external drive if at all possible. If this data is not backed up prior to replacing the disk drive all instrument adjustments and performance verification tests will need to be run after the drive is replaced.

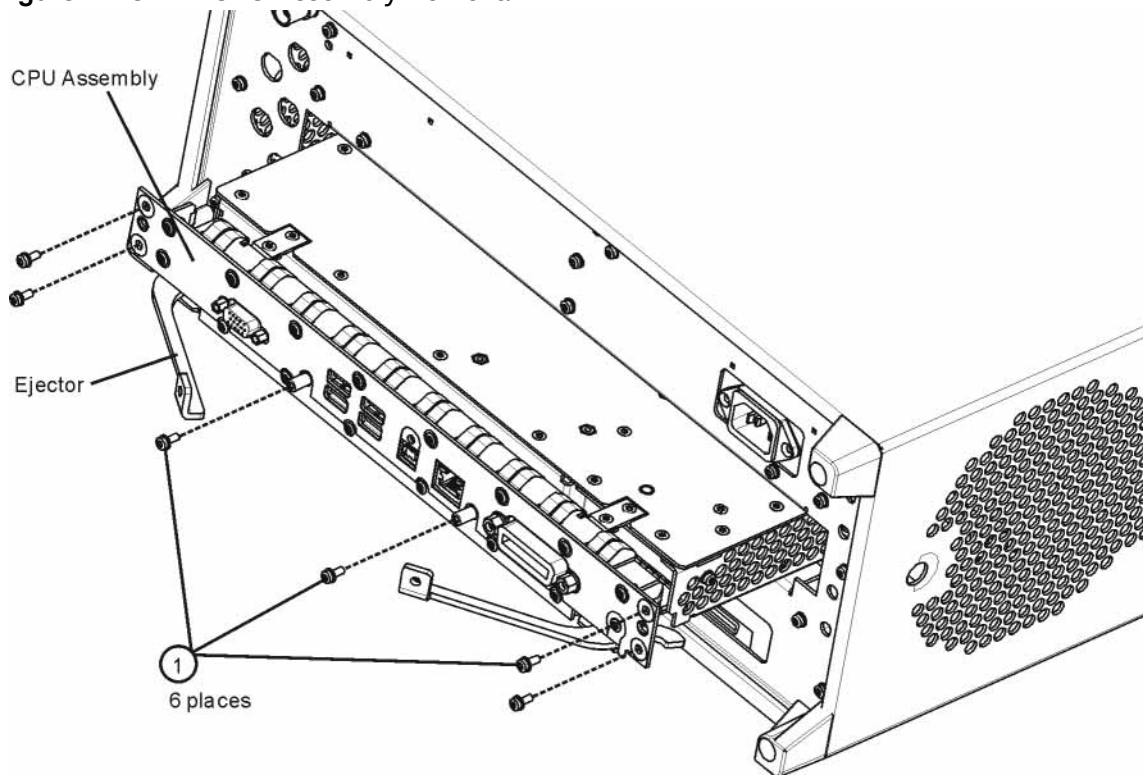
For information on how to backup this data see the “[Calibration Data Backup and Restore](#)” section in [Chapter 15, “Post-Repair Procedures.”](#) of this manual.

If this data cannot be backed up because the instrument will not fully boot, go ahead and change the A5 Disk Drive and perform all adjustments listed in [Chapter 15, “Post-Repair Procedures.”](#) for the A5 assembly.

2. Turn the instrument off and remove the AC power cord.

3. Refer to **Figure 14-54**. Locate and remove the existing CPU assembly from the instrument by removing the 6 rear panel screws (1). The CPU assembly can be removed from the chassis by pulling straight out the back. Use the two ejectors to pull the CPU assembly out from the chassis.

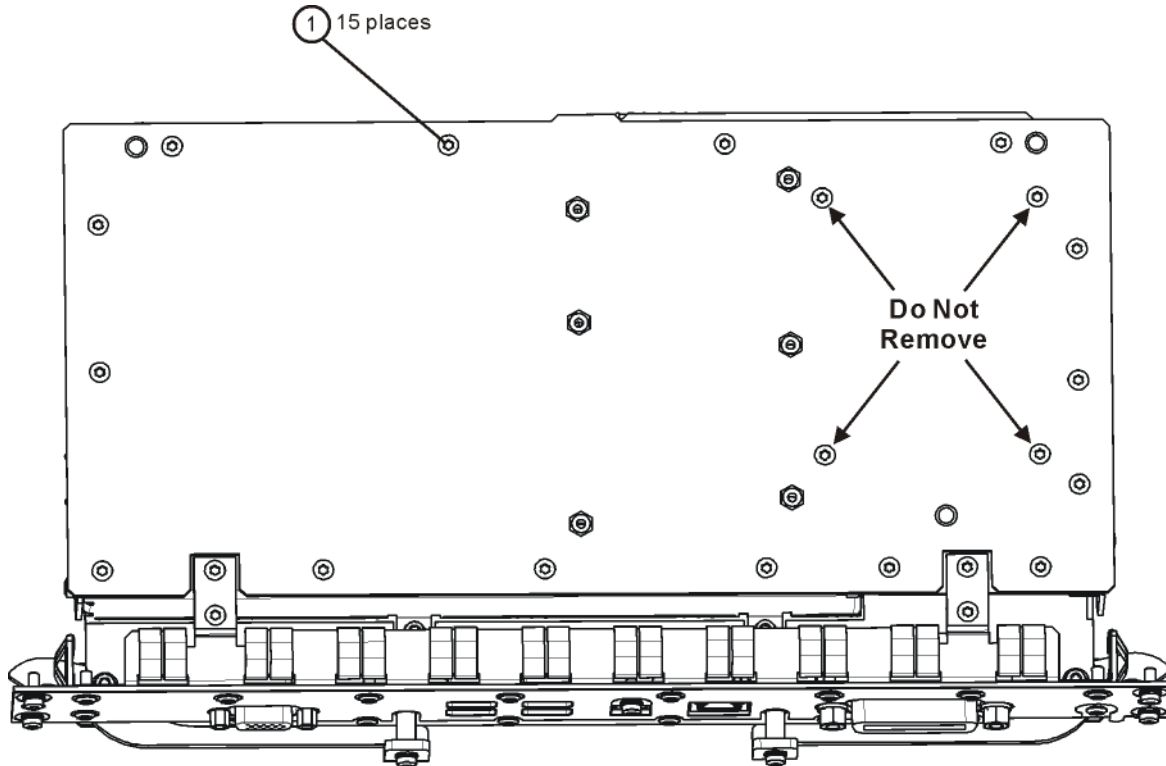
**Figure 14-54** CPU Assembly Removal



4. Refer to **Figure 14-55**. Remove and discard the 15 machine screws (1) from the CPU assembly. The screws need to be discarded because dried precoated screws can cause cross threading.

**NOTE** Do not remove the 4 Hard Drive screws yet.

**Figure 14-55** CPU Top Shield Screws

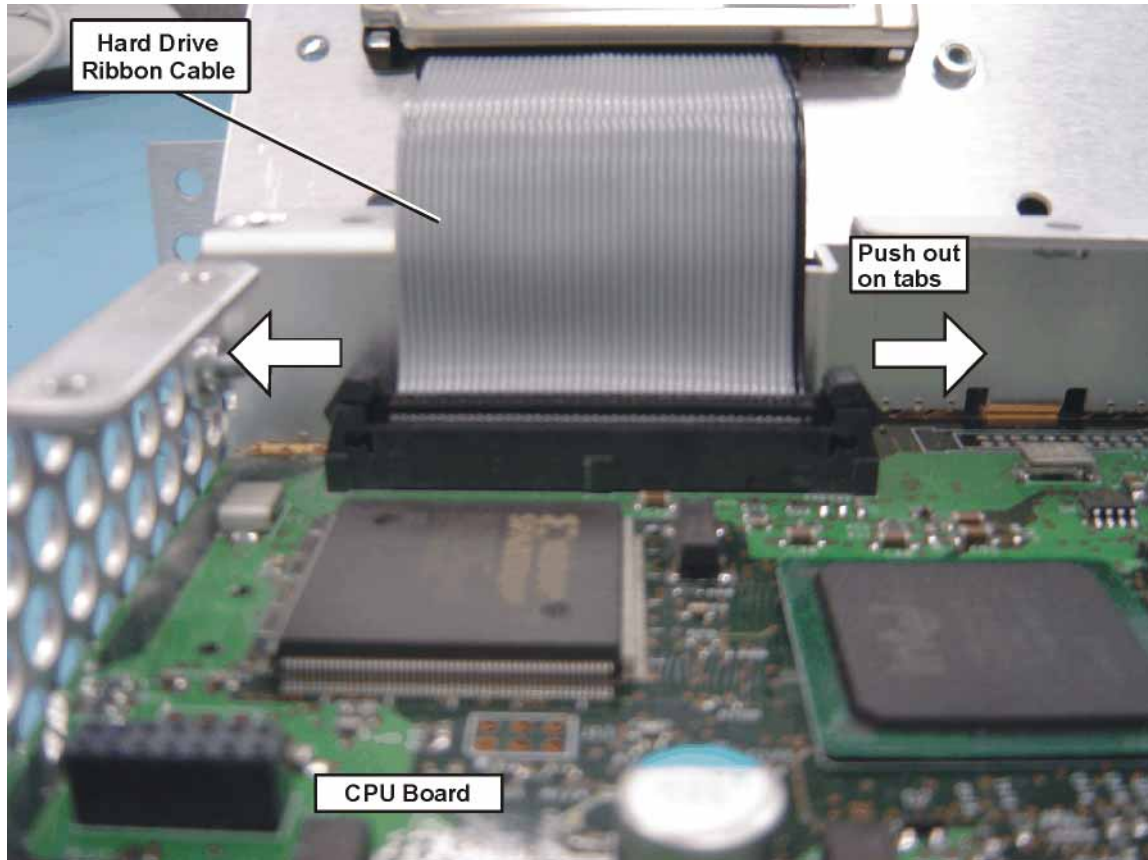


cpu\_topscrews



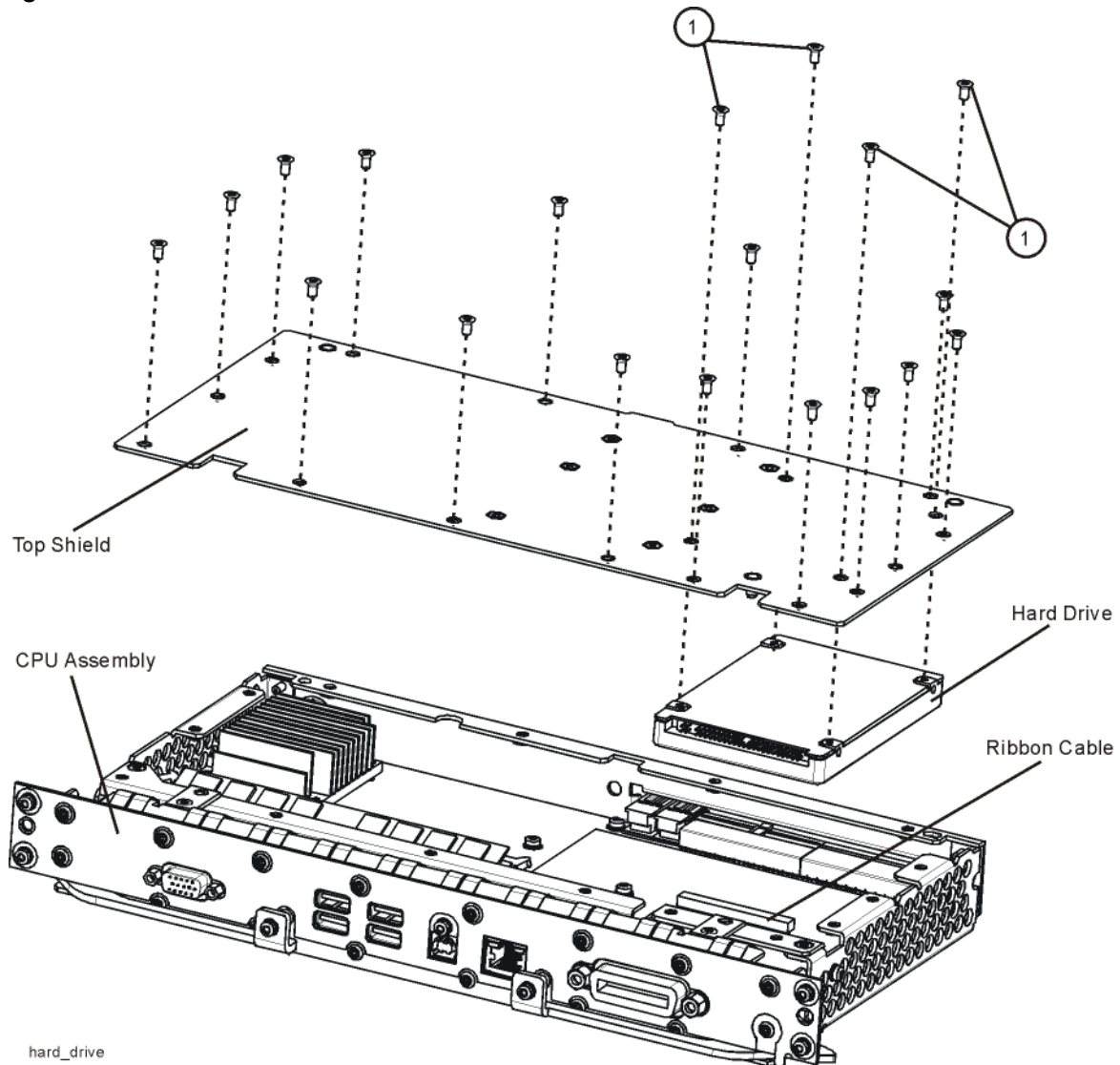
5. Refer to **Figure 14-56**. Carefully lift up the CPU top shield and unlock the Hard Drive ribbon cable from the CPU Board by pressing down and out on the two locking tabs located on the sides of the connector as shown.

**Figure 14-56** Hard Drive Ribbon Cable



6. Refer to **Figure 14-57**. Uninstall the existing Hard Drive from the Top Shield by removing and discarding the 4 machine screws (1) from the CPU assembly. Screws need to be discarded because dried precoated screws can cause cross threading.

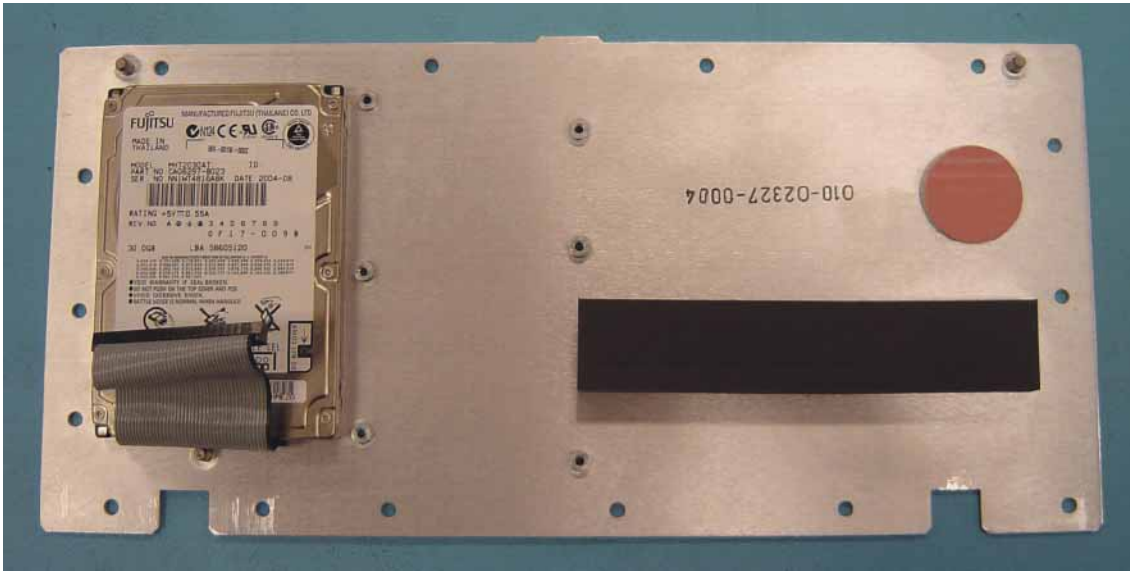
**Figure 14-57** CPU/Hard Drive Parts



7. Remove the ribbon cable from the Hard Disk Drive and set the ribbon cable aside. Discard the defective Hard Disk Drive.
8. Locate the Programmed Hard Disk Drive.
9. Connect the Hard Drive ribbon cable to the Programmed Hard Disk Drive.

10. Install the Programmed Hard Disk Drive to the Top Shield using precoated four Machine Screws (0515-5074) as shown in [Figure 14-58](#). Torque screws to 9 inch-pounds.

**Figure 14-58** Top Shield/Hard Drive Assembly



11. Connect the Hard Drive ribbon cable from the Top Shield/Hard Drive/Ribbon Cable assembly to the CPU assembly. When the ribbon cable is fully seated the two locking tabs will grip the sides of the ribbon cable connector.
12. Install the Top Shield/Hard Drive/Ribbon Cable assembly to the CPU assembly using fifteen precoated Machine Screws (0515-5074). Torque screws to 9 inch-pounds.
13. Refer to [Figure 14-54](#). Replace the CPU assembly in the instrument with 6 screws. Torque to 9 inch-pounds.

14. Locate the Windows Vista License Sticker that came with the replacement hard drive and apply the sticker to the rear of the instrument as shown in [Figure 14-59](#), covering the existing sticker if present.

**Figure 14-59** Windows License Sticker Rear Panel Location



**NOTE**

While the replacement disk drive has the Windows XP operating system loaded onto it, the license that accompanies it in this kit is for Windows Vista. This is being done within the scope of our license agreement with Microsoft and is necessary at this time, as the instrument applications software is not supported or qualified with any operating system other than Windows XP.

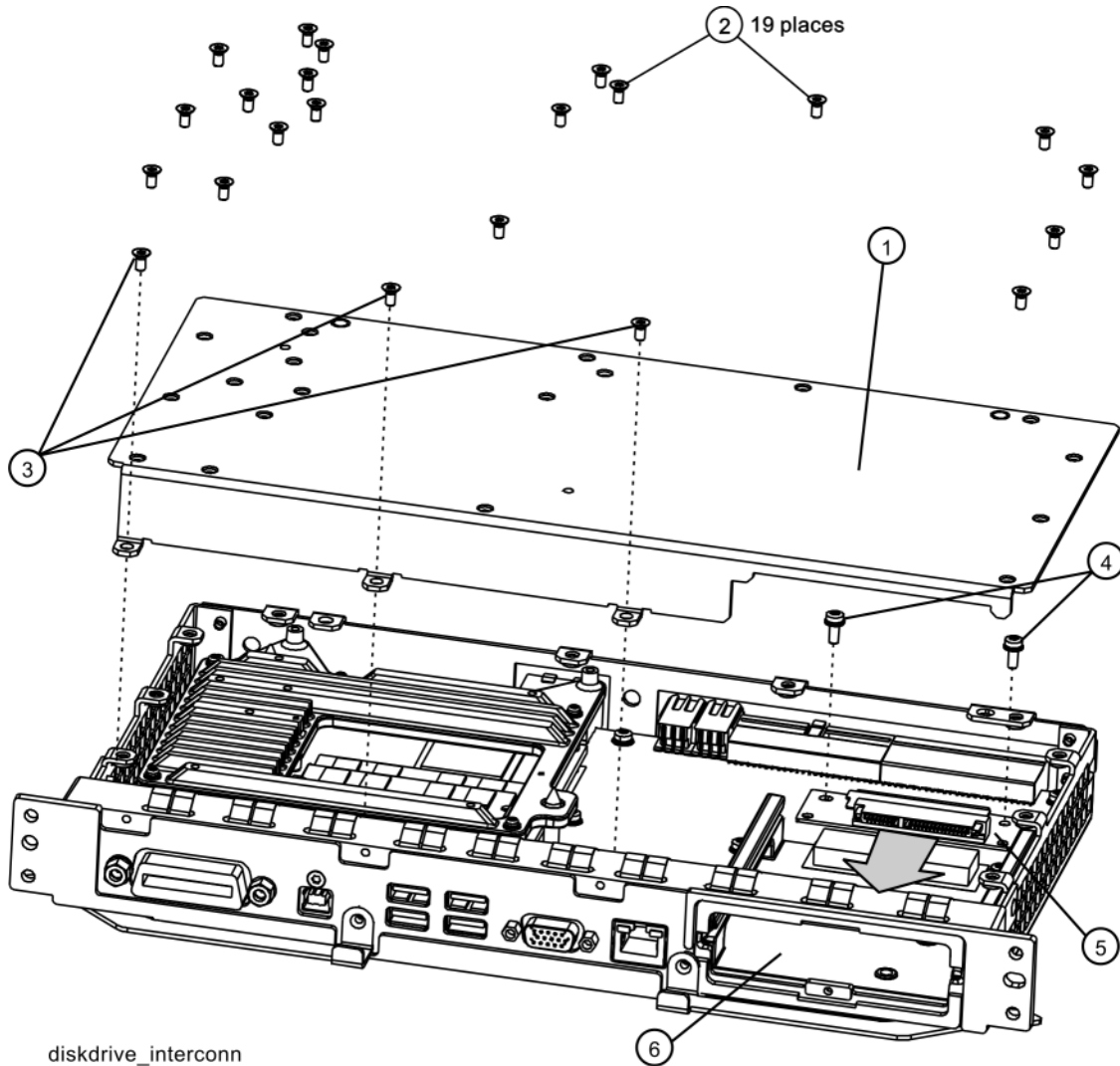
- 
15. Refer to [Chapter 15, "Post-Repair Procedures."](#) and perform all of the specified tasks for replacing the A5 Disk Drive assembly.

## Disk Drive Interconnect

### Removal

1. Remove the A5 Disk Drive assembly for the instrument. Refer to the “Internally Mounted Disk Drive” removal procedure.
2. Remove the A4 CPU assembly from the instrument. Refer to the “CPU Assembly” removal procedure.
3. Refer to Figure 14-60. Remove the A4 CPU assembly cover (1) by first removing the 19 flat-head screws (2) and 3 pan-head screws (3). The 19 flat-head screws need to be discarded and replaced since they are precoated with a thread locking compound and new screws will need to be used when the cover is re-installed.

Figure 14-60 A4A1 Disk Drive Interconnect Board Removal



4. Remove the 2 screws **(4)** that attached the A4A1 Disk Drive Interconnect board **(5)** to the A4 CPU assembly.
5. Unplug and remove the A4A1 Disk Drive Interconnect board from the A4 CPU assembly by carefully sliding the board out towards the disk drive bay opening **(6)**.

#### Installation

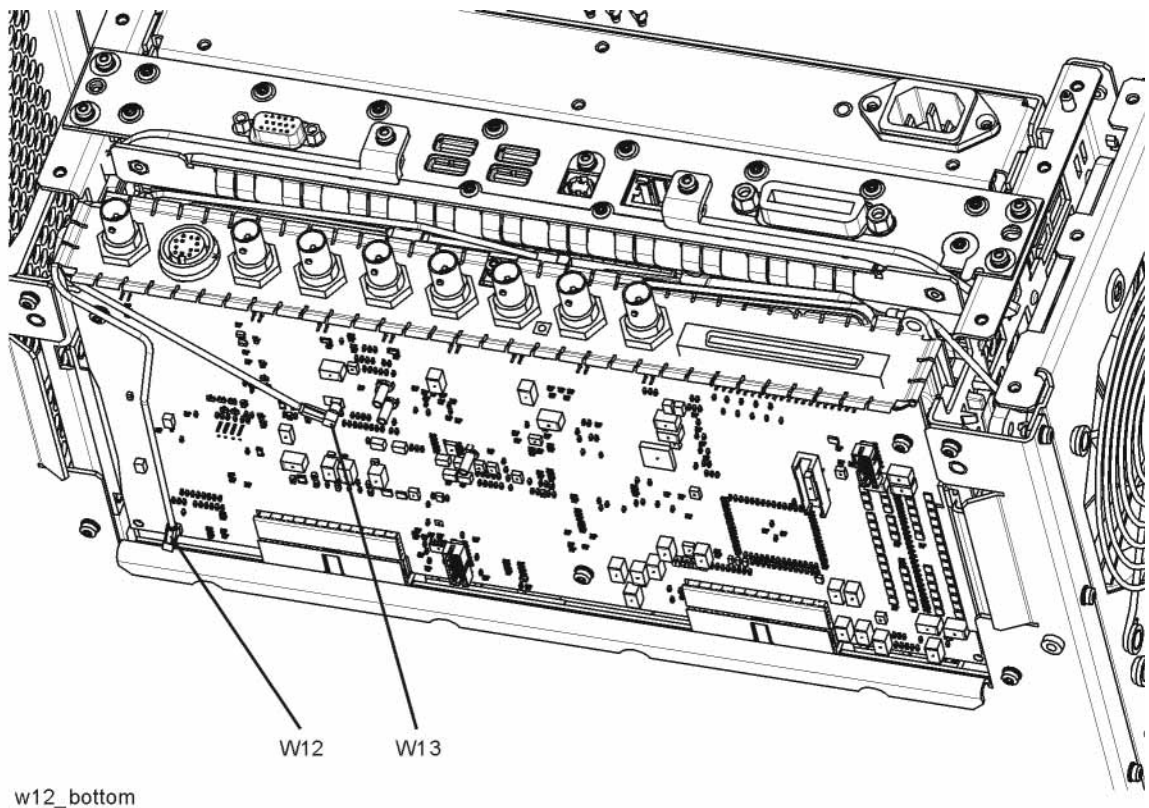
1. Refer to **Figure 14-60**. Plug the A4A1 Disk Drive Interconnect board **(5)** into the A4 CPU assembly by carefully sliding it into place from the disk drive bay opening **(6)**.
2. Install the 2 screws **(4)** that secure the A4A1 Disk Drive Interconnect board to the A4 CPU assembly and torque them to 9 inch-lbs.
3. Replace the A4 CPU assembly cover **(1)** and attach it with 19 new flat-head screws **(2)** and the 3 pan-head screws **(3)**. Torque all screws to 9 inch-lbs.
4. Re-install the A4 CPU assembly into the instrument. Refer to the CPU Assembly installation procedure.
5. Re-install the A5 Disk Drive assembly into the instrument. Refer to the Disk Drive installation procedure.

## Analog I.F. (AIF)/Digital I.F. (DIF) Assembly

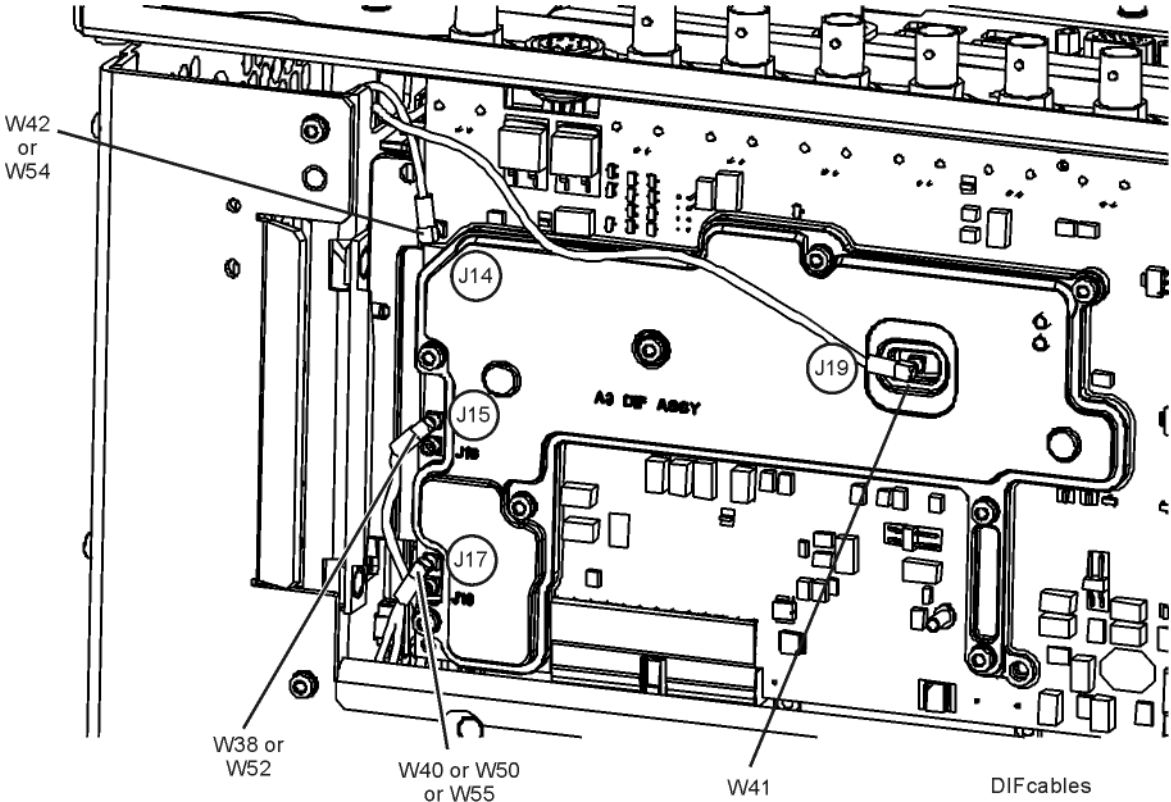
### Removal

1. Remove the instrument outer case. Refer to the Instrument Outer Caseremoval procedure.
2. Remove the rear panel. Refer to the Rear Panelremoval procedure.
3. Refer to **Figure 14-61** and **Figure 14-62**. Depending on the age of your instrument and the installed options, remove the appropriate cables from the bottom of the DIF assembly.

**Figure 14-61** W12, W13 Removal - Standard Instruments



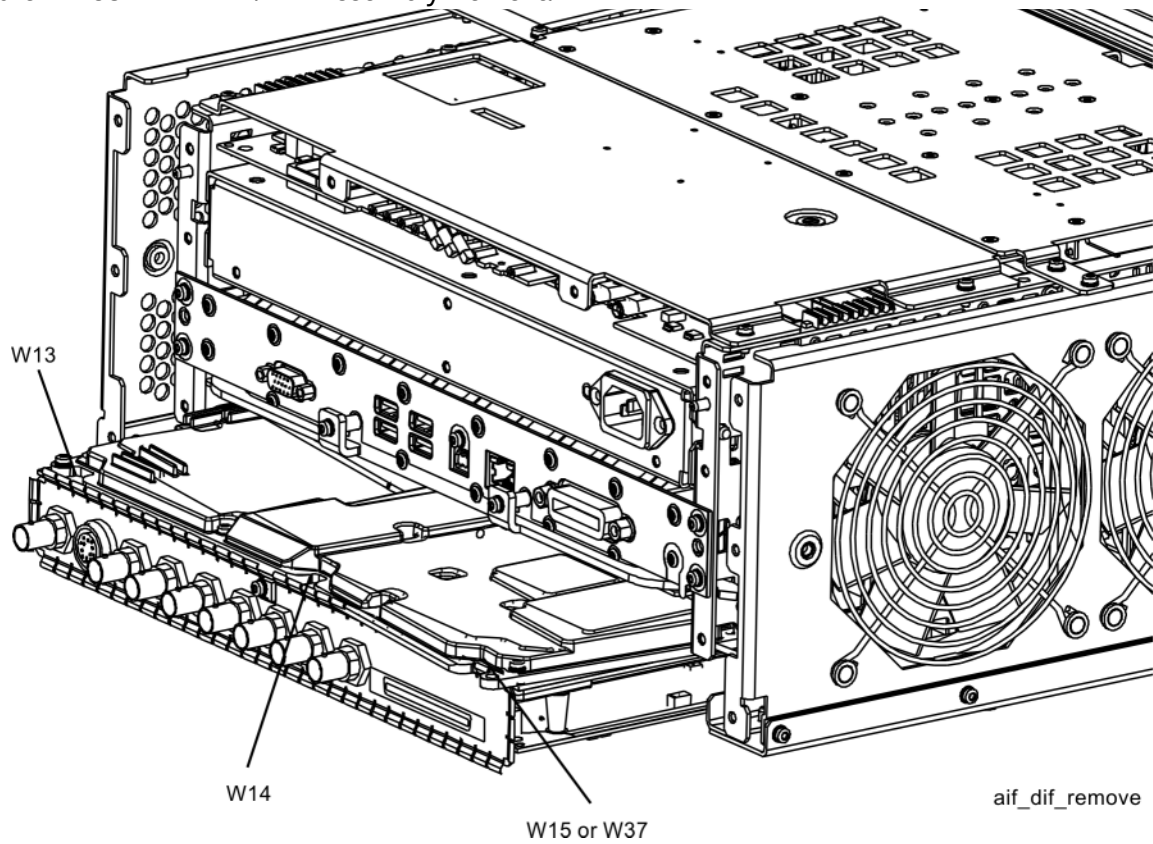
**Figure 14-62** W38, W40, W41, W42 Removal - Option B40, MPB, or DP2





4. Refer to **Figure 14-63**. Pull the AIF/DIF assembly part way out of the chassis. Remove cables W13, W14, and W15 or W37 from the AIF assembly.
5. The AIF/DIF assembly can be removed from the chassis by pulling straight out the back.

Figure 14-63 AIF/DIF Assembly Removal

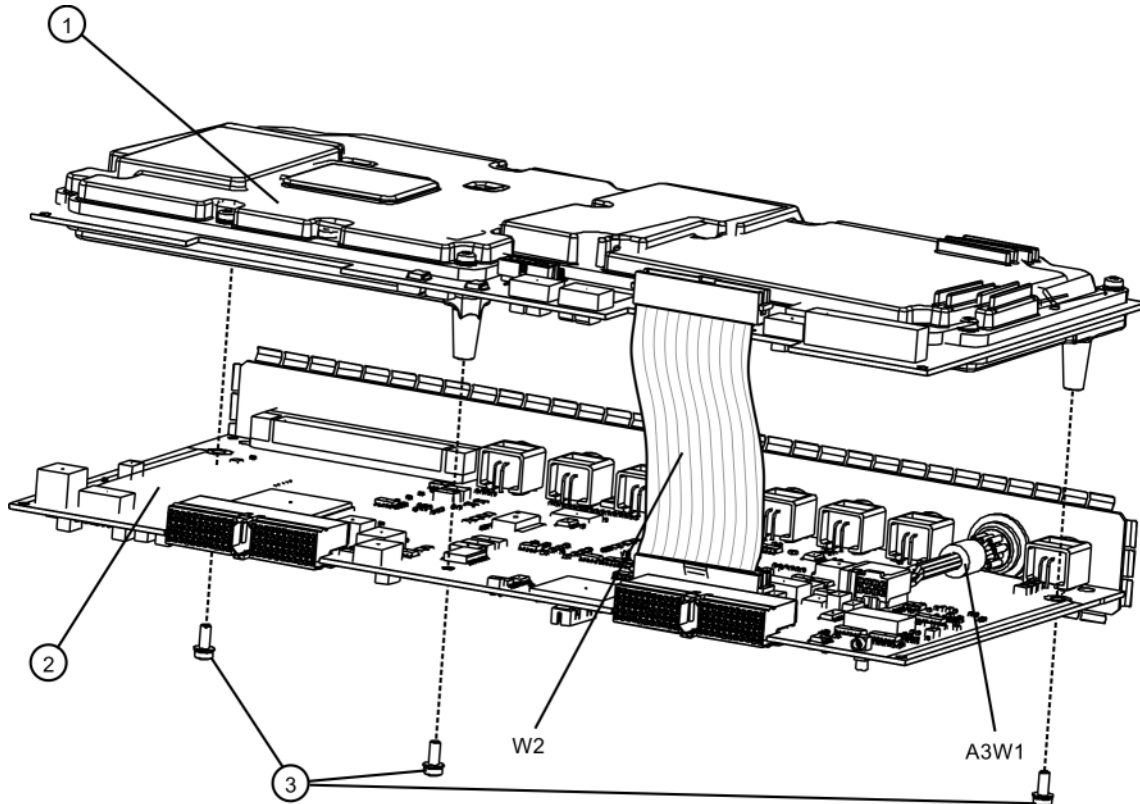


## Separate AIF/DIF Assembly

1. To separate the AIF (1) from the DIF (2), unplug ribbon cable W2 from the AIF assembly.
2. Refer to **Figure 14-64**. From underneath the assembly, remove the three screws (3).

Figure 14-64

AIF/DIF Separation



aif\_dif\_separate

## AIF/DIF Pre-installation

1. Set the DIF in position over the AIF. Reinstall the three screws removed before. Torque to 9 inch-pounds, starting with the middle screw.
2. To reconnect the AIF and the DIF, reconnect the ribbon cable W2.

## Replacement

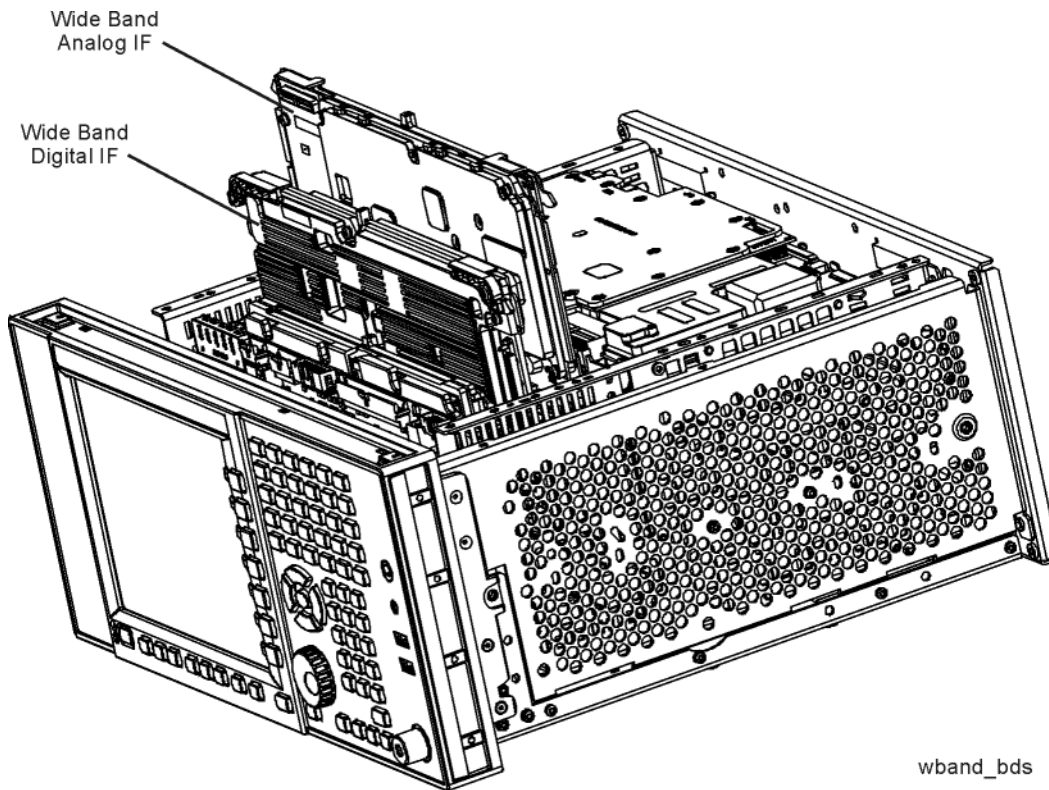
1. Slide the AIF/DIF assembly into the slot at the rear of the instrument and push on the assembly to mate the connectors to the midplane assembly.
2. Refer to **Figure 14-63**. Replace cables W13, W14, and W15 or W37 to the AIF assembly.
3. Refer to **Figure 14-61** and **Figure 14-62**. Replace the appropriate cables to the bottom of the DIF assembly.
4. Replace the rear panel. Refer to the Rear Panelreplacement procedure.
5. Replace the instrument outer case. Refer to the Instrument Outer Casereplacement procedure.

## Wide Band Analog IF and Digital IF Assemblies

### Removal

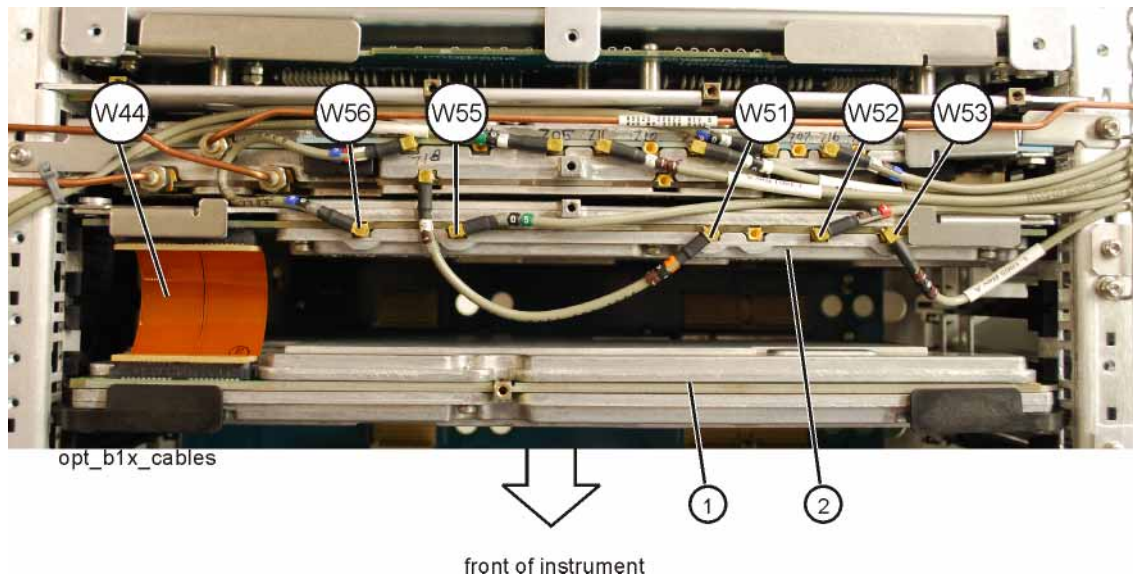
1. Remove the instrument outer case. Refer to the Instrument Outer Case removal procedure.
2. Remove the instrument top brace. Refer to the Top Brace and Reference Bracket removal procedure.
3. Refer to **Figure 14-65**. Locate the Wideband Analog IF and Wideband Digital IF assemblies.

**Figure 14-65** Wideband I.F. Assemblies Location



4. Refer to **Figure 14-66**. Remove cables W51, W52, W53, W55, and W56 from the Wideband Analog IF assembly (2).
5. Remove ribbon cable W44.

**Figure 14-66** Option B1X Cables



6. The Wideband Analog IF (2) and Wideband Digital IF (1) assemblies can now be removed by pulling up on the ejectors to remove from the chassis.

## Replacement

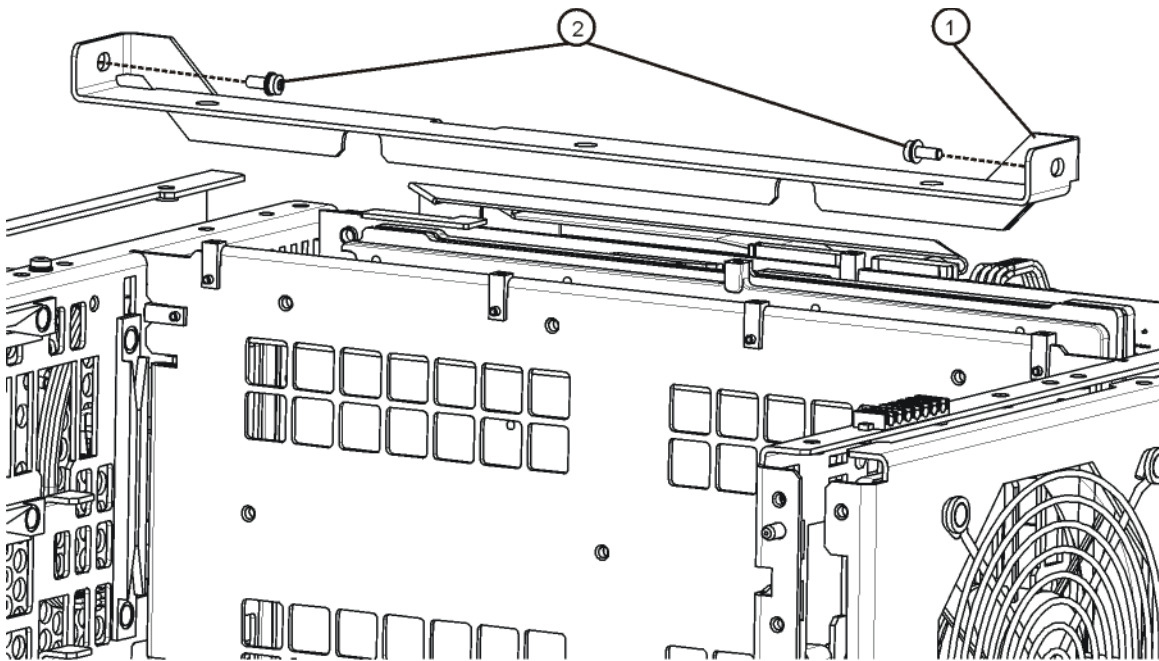
1. Slide the Wideband Analog IF assembly into slot 3 in the chassis and use the ejectors to push into place into the motherboard.
2. Slide the Wideband Digital IF assembly into slot 5 in the chassis and use the ejectors to push into place into the motherboard.
3. Refer to **Figure 14-66**. Reinstall cables W51, W52, W53, W55, and W56 to the Wideband Analog IF assembly (2).
4. Reconnect ribbon cable W44.
5. Replace the instrument top brace. Refer to the Top Brace and Reference Bracket replacement procedure.
6. Replace the instrument outer case. Refer to the Instrument Outer Casereplacement procedure.

## Midplane Assembly

### Removal

1. Remove the instrument outer case. Refer to the Instrument Outer Caseremoval procedure.
2. Remove the rear panel. Refer to the Rear Panelremoval procedure.
3. Remove the top brace and reference bracket. Refer to the Top Brace and Reference Bracket removal procedure.
4. Remove the reference assembly. Refer to the Reference Assembly removal procedure.
5. Remove the CPU assembly. Refer to the CPU Assembly removal procedure.
6. Remove the power supply assembly. Refer to the Power Supply Assembly removal procedure.
7. Refer to **Figure 14-67**. Remove the power supply support bracket (1) by removing the two screws (2).

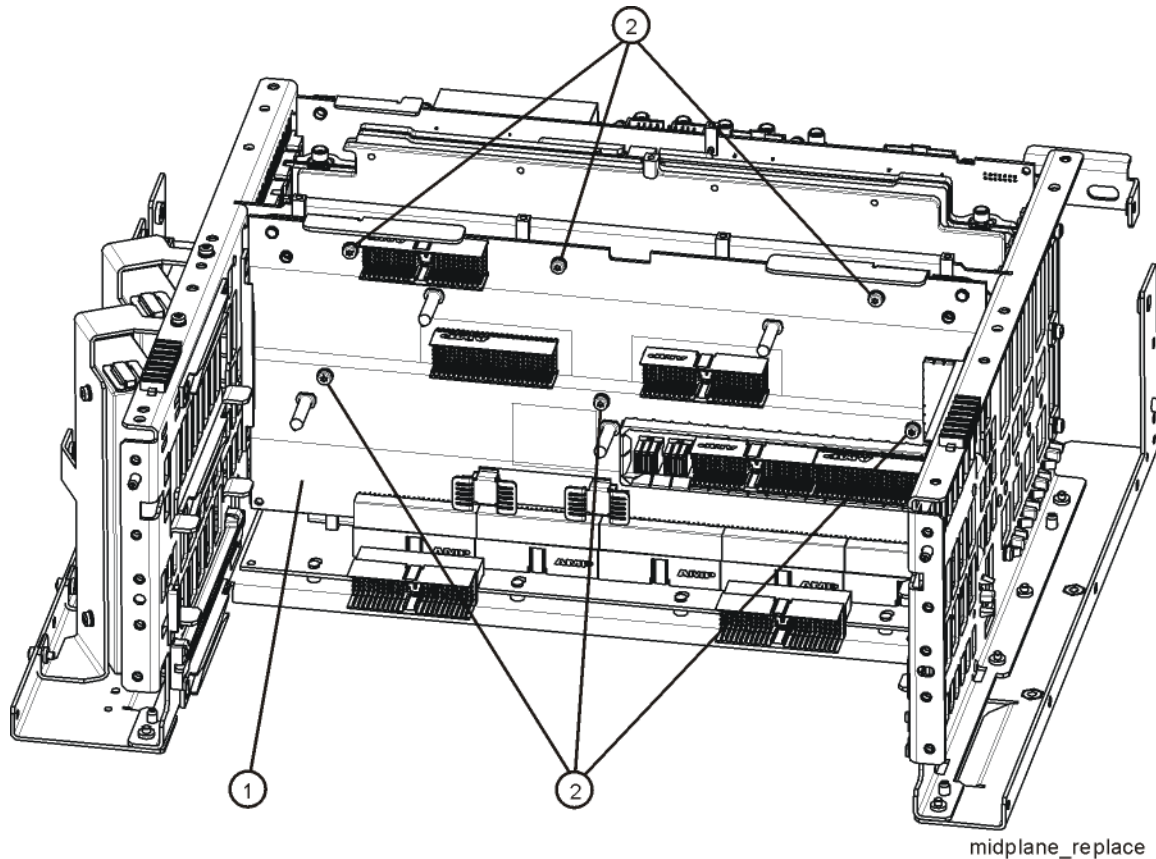
**Figure 14-67** Power Supply Bracket



power\_supply\_bracket

8. Refer to **Figure 14-68**. Remove the six screws (2) attaching the midplane assembly (1) to the midplane bracket. The midplane assembly can now be pulled up from the chassis by leveraging up on the ejectors.

**Figure 14-68** Midplane Assembly Removal



## Replacement

1. Refer to **Figure 14-68**. Install the midplane assembly into the chassis and attach to the midplane bracket using the six screws (2) removed earlier. Torque to 9 inch-pounds.
2. Replace the power supply support bracket with the two screws. Torque to 9 inch-pounds.
3. Replace the power supply assembly. Refer to the Power Supply Assembly replacement procedure.
4. Replace the CPU assembly. Refer to the CPU Assembly replacement procedure.
5. Replace the reference assembly. Refer to the Reference Assembly replacement procedure.

- 6.** Replace the top brace and reference bracket. Refer to the Top Brace and Reference Bracket replacement procedure.
- 7.** Replace the rear panel. Refer to the Rear Panelreplacement procedure.
- 8.** Replace the instrument outer case. Refer to the Instrument Outer Casereplacement procedure.

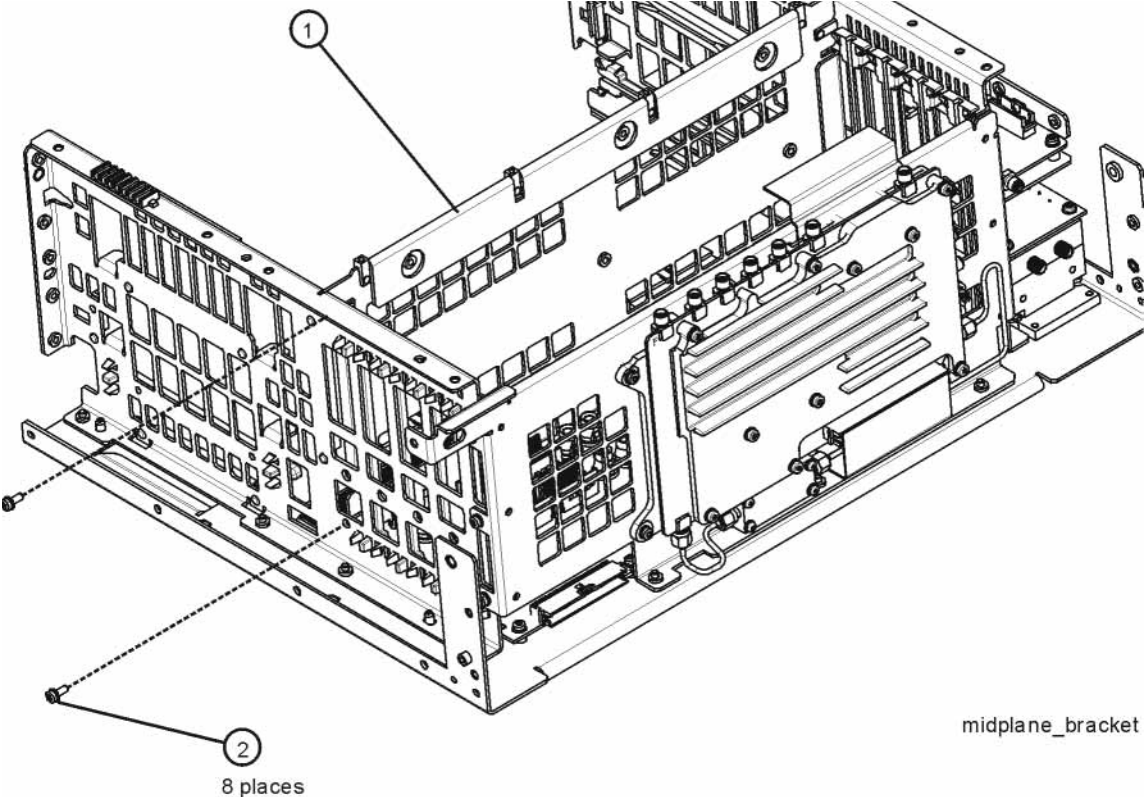


## Motherboard Assembly

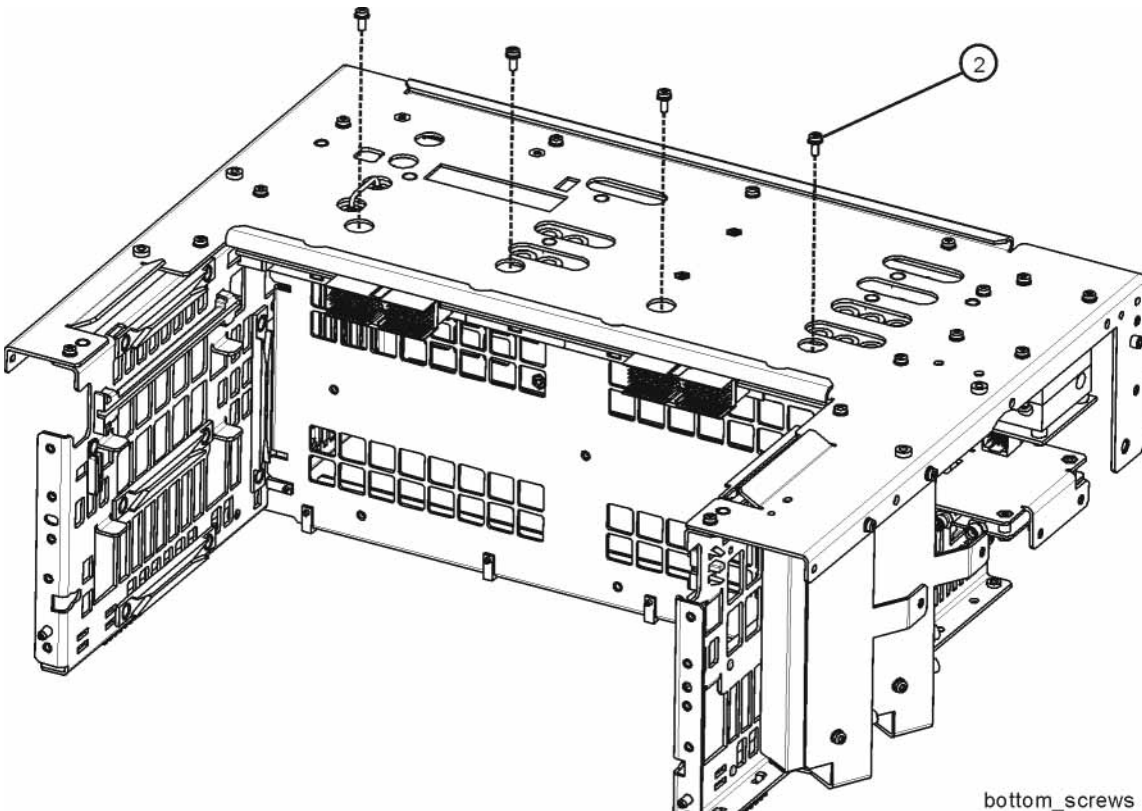
### Removal

1. Remove the instrument outer case. Refer to the Instrument Outer Case removal procedure.
2. Remove the rear panel. Refer to the Rear Panel removal procedure.
3. Remove the top brace and reference bracket. Refer to the Top Brace and Reference Bracket removal procedure.
4. Remove the reference assembly. Refer to the Reference Assembly removal procedure.
5. Remove the CPU assembly. Refer to the CPU Assembly removal procedure.
6. Remove the power supply assembly. Refer to the Power Supply Assembly removal procedure.
7. Remove the AIF/DIF assembly. Refer to the Analog I.F. (AIF)/Digital I.F. (DIF) Assembly removal procedure.
8. Remove the Front End Control assembly. Refer to the Front End Control Assembly removal procedure.
9. Remove the L.O. Synthesizer assembly. Refer to the L.O. Synthesizer Assembly removal procedure.
10. Remove the Midplane assembly. Refer to the Midplane Assembly removal procedure.
11. Remove the Front Frame Assembly. Refer to the Front Frame Assembly removal procedure.
12. Remove the RF bracket. Refer to [Figure 14-9 on page 449](#).
13. Remove the fan assembly. Refer to the Fan Assembly removal procedure.
14. Refer to [Figure 14-69](#) and [Figure 14-70](#). Remove the midplane bracket **(1)** by removing the eight screws **(2)** (two on each side and four on the bottom).

**Figure 14-69** Midplane Bracket Removal

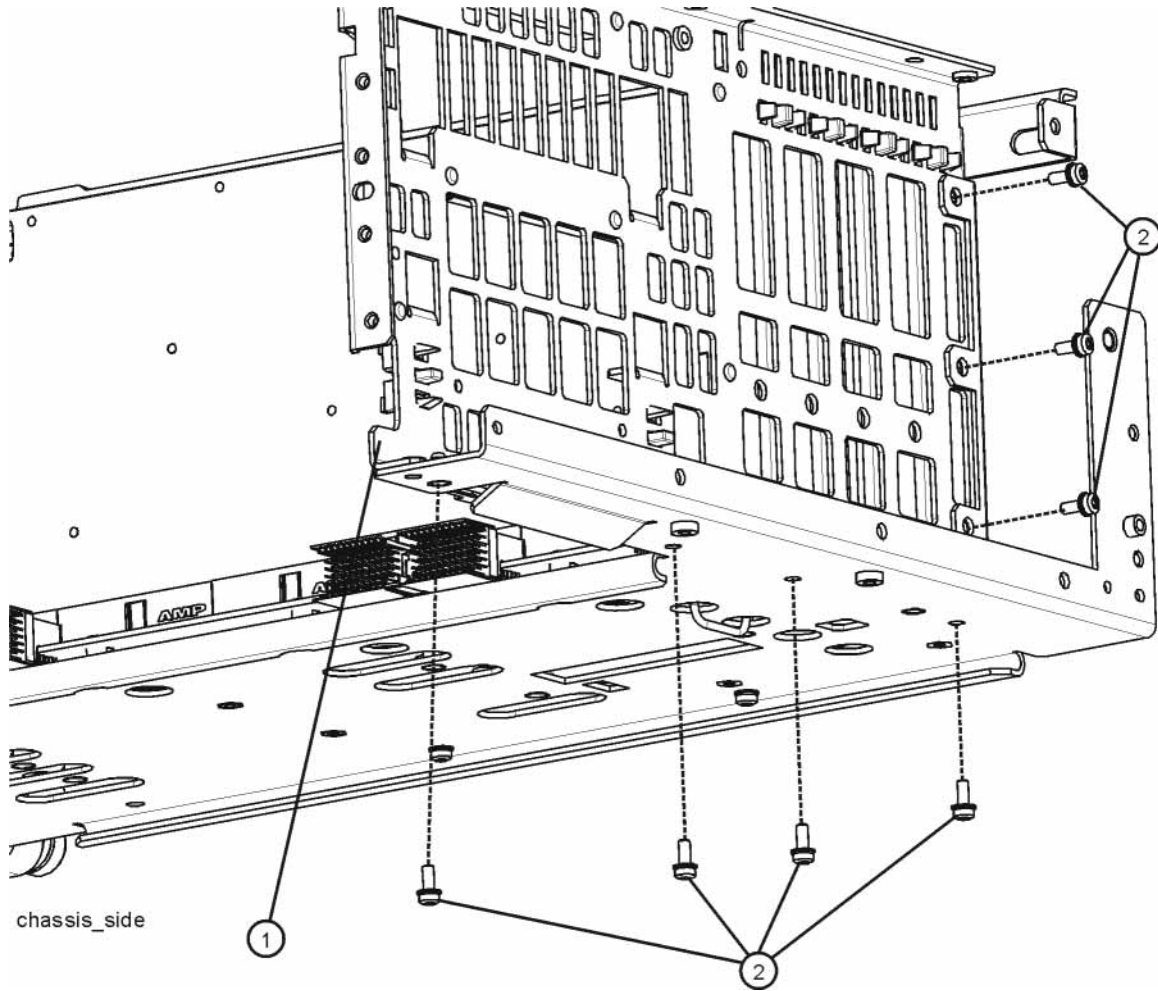


**Figure 14-70** Bottom Screws



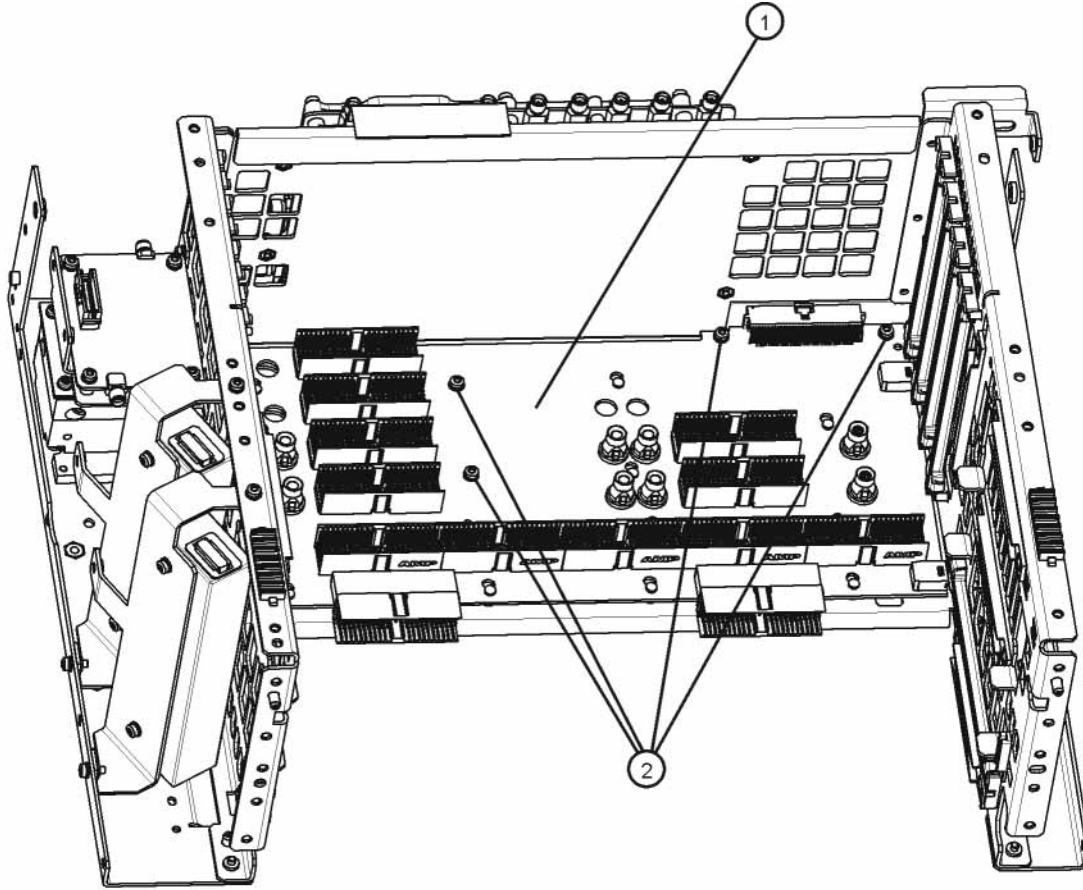
15. Refer to **Figure 14-71**. Remove the left side chassis (same side as the fan) by removing the seven screws (four on the bottom).

**Figure 14-71** Chassis Side Removal



16. Refer to **Figure 14-72**. Remove the motherboard (1) by removing the four screws (2).

**Figure 14-72** Motherboard Assembly Removal



motherboard\_replace

## Replacement

1. Refer to **Figure 14-72**. Place the motherboard (1) into position in the chassis and replace the four screws (2). Torque to 9 inch-pounds.
2. Refer to **Figure 14-71**. Replace the left side chassis by replacing the seven screws. Torque to 9 inch-pounds.
3. Refer to **Figure 14-69**. Replace the midplane bracket (1) by replacing the eight screws (2). Torque to 9 inch-pounds.
4. Replace the fan assembly. Refer to the Fan Assembly replacement procedure.
5. Replace the RF bracket. Refer to **Figure 14-9 on page 449**. Torque the screws to 9 inch-pounds.

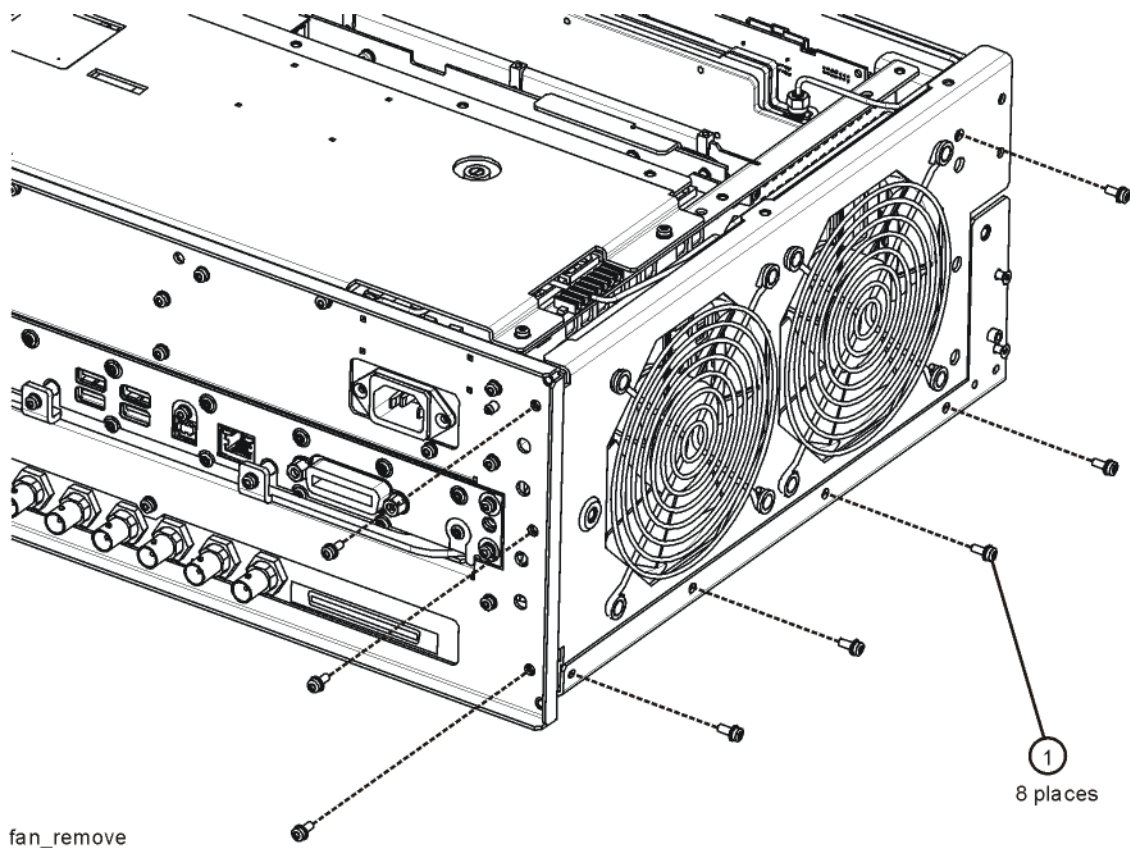
- 6.** Replace the Front Frame Assembly. Refer to the Front Frame Assembly replacement procedure.
- 7.** Replace the Midplane assembly. Refer to the Midplane Assembly replacement procedure.
- 8.** Replace the L.O. Synthesizer assembly. Refer to the L.O. Synthesizer Assembly replacement procedure.
- 9.** Replace the Front End Control assembly. Refer to the Front End Control Assembly replacement procedure.
- 10.** Replace the AIF/DIF assembly. Refer to the Analog I.F. (AIF)/Digital I.F. (DIF) Assembly replacement procedure.
- 11.** Replace the power supply assembly. Refer to the Power Supply Assembly replacement procedure.
- 12.** Replace the CPU assembly. Refer to the CPU Assembly replacement procedure.
- 13.** Replace the reference assembly. Refer to the Reference Assembly replacement procedure.
- 14.** Replace the top brace and reference bracket. Refer to the Top Brace and Reference Bracket replacement procedure.
- 15.** Replace the rear panel. Refer to the Rear Panel replacement procedure.
- 16.** Replace the instrument outer case. Refer to the Instrument Outer Case replacement procedure.

## Fan Assembly

### Removal

1. Remove the instrument outer case. Refer to the Instrument Outer Caseremoval procedure.
2. Remove the top brace. Refer to the Top Brace and Reference Bracket removal procedure.
3. Remove the Front Frame Assembly. Refer to the Front Frame Assembly removal procedure.
4. Refer to **Figure 14-73**. Remove the eight screws (1) that attach the fan assembly to the chassis.

**Figure 14-73** Fan Assembly Removal

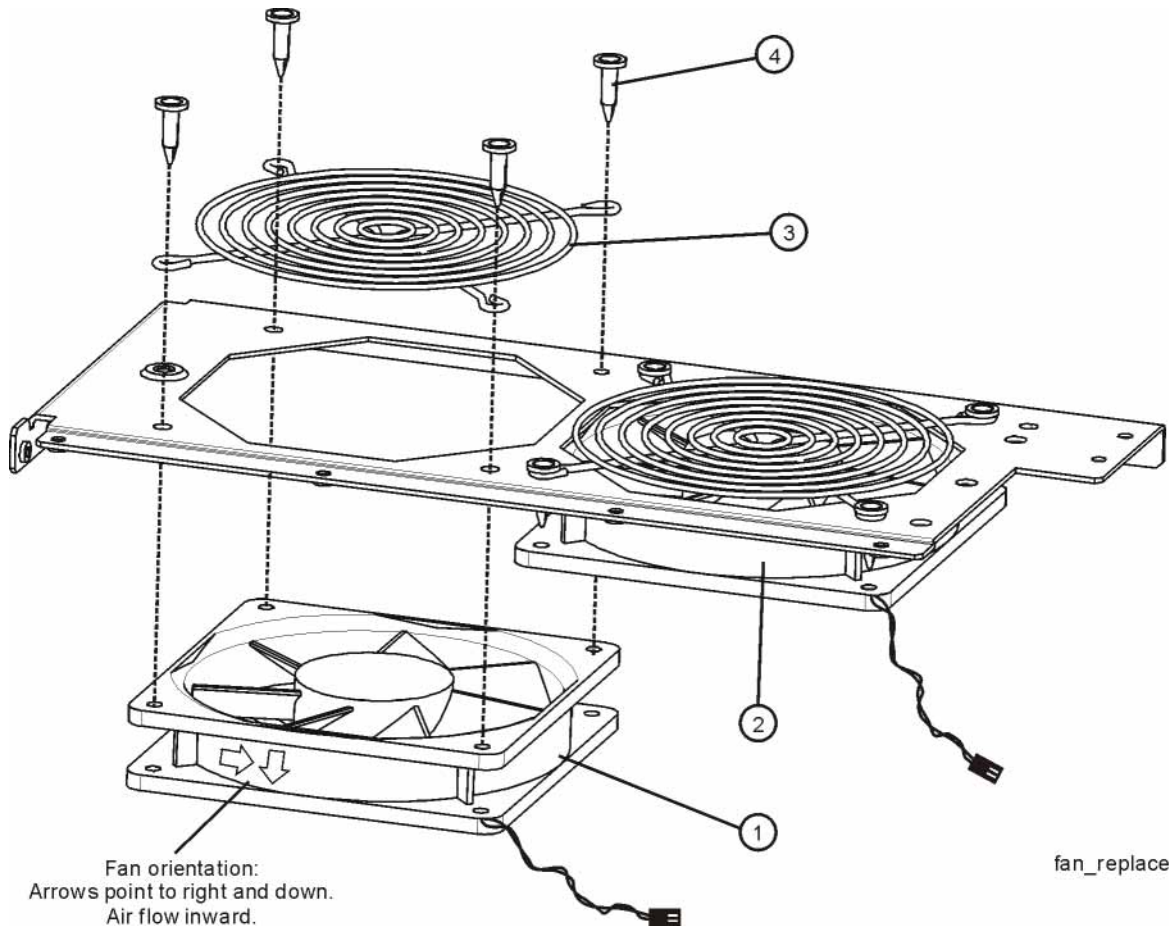


5. Unplug the fan wires from the motherboard. The fan assembly can now be lifted from the chassis.

## Replacing a Fan

1. Refer to **Figure 14-74**. To replace a fan, it is necessary to remove the 4 plastic rivets (**4**) that attach the fan (**1**) and guard (**3**) to the fan bracket. To do this use a small screwdriver to unscrew the rivet and remove it from the bracket.

**Figure 14-74** Fan Replacement



2. Position the new fan on the work surface with the arrows pointing to the right and down.
3. Orient the fan guard so that the rings are on the outside, and that the “V” of the support legs are pointing to the neighboring fan.
4. With the rivets center posts raised, snap the rivets into place through the fan grill and fan bracket and into the fan. Screw the center posts into place.

## Replacement

1. Plug the fan wires into the motherboard.

2. Refer to **Figure 14-73**. Place the fan assembly into position in the chassis. Replace the eight screws **(1)** to attach the fan assembly to the chassis. Torque to 9 inch-pounds.
3. Replace the Front Frame Assembly. Refer to the Front Frame Assembly replacement procedure.
4. Replace the top brace. Refer to the Top Brace and Reference Bracket replacement procedure.
5. Replace the instrument outer case. Refer to the Instrument Outer Casereplacement procedure.

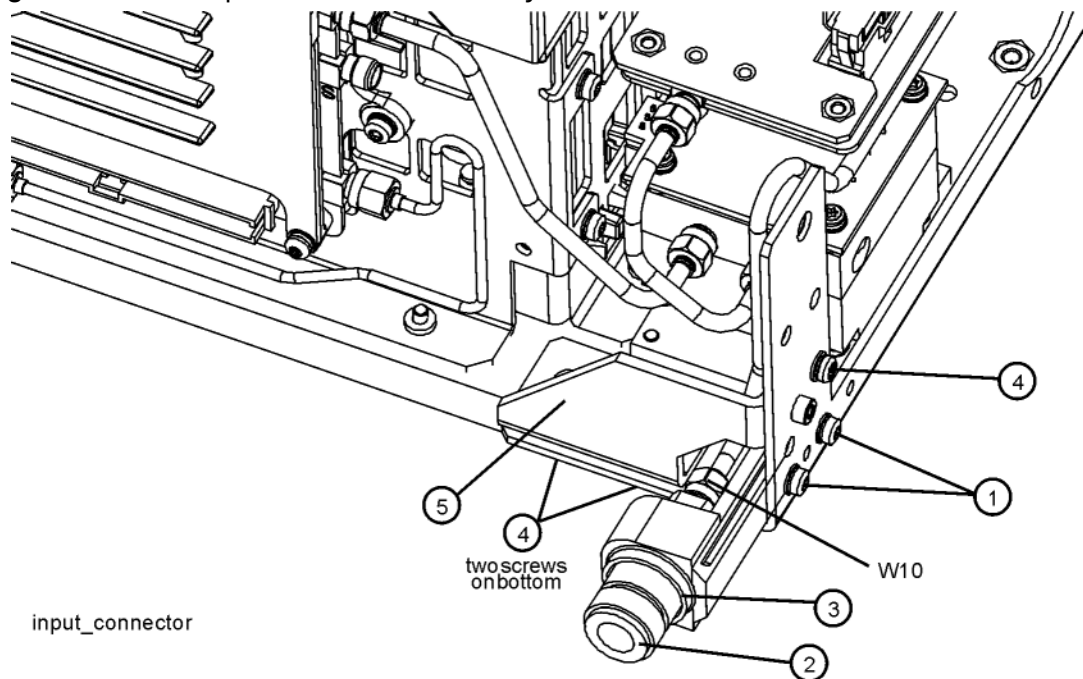


## Input Connector Assembly

### Removal

1. Remove the instrument outer case. Refer to the Instrument Outer Caseremoval procedure.
2. Remove the Front Frame Assembly. Refer to the Front Frame Assembly removal procedure.
3. Refer to **Figure 14-75**. Disconnect the semi-rigid cable W10 from the Input Connector Assembly (2).

**Figure 14-75** Input Connector Assembly Removal



4. Remove the two screws (1) that attach the Input Connector Assembly (2) to the chassis. The connector assembly can now be lifted from the chassis.
5. To remove the gusset (5) remove the three screws (4), one on the side of the chassis and two on the bottom.

### Replacement

1. Refer to **Figure 14-75**. Place the Input Connector Assembly (2) into position in the chassis. Replace the two screws (1) to attach the Input Connector Assembly to the chassis. Torque to 9 inch-pounds.

**NOTE**

Make sure that the O-ring (3) is installed correctly on the input connector.

---

2. Reconnect the semi-rigid cable W10 to the Input Connector Assembly. Torque to 10 inch-pounds.
3. Place the gusset (5) in position and replace the three screws (4) that attach it to the chassis. Torque to 9 inch-pounds.
4. Replace the Front Frame Assembly. Refer to the Front Frame Assembly replacement procedure.
5. Replace the instrument outer case. Refer to the Instrument Outer Casereplacement procedure.

## Front Frame Assembly

### Removal

**NOTE** Make sure any connectors on the front panel are removed.

---

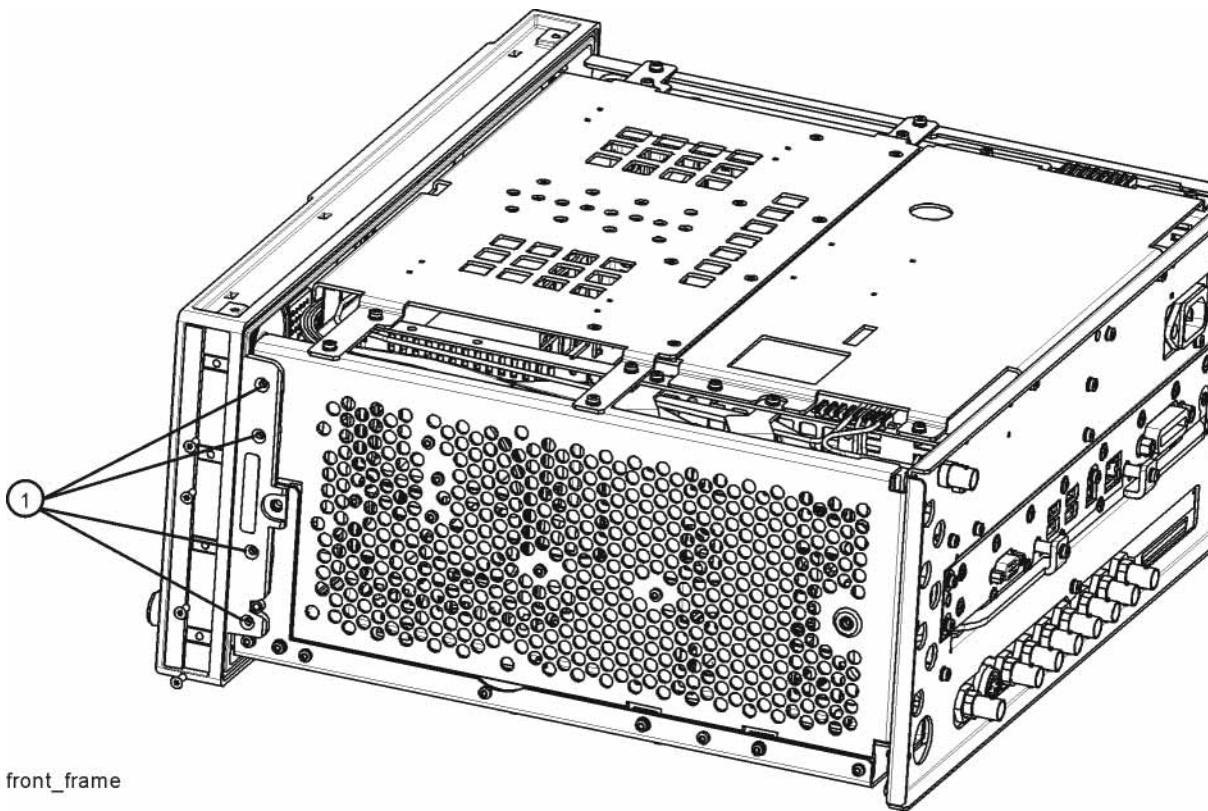
1. Remove the instrument outer case. Refer to the Instrument Outer Case removal procedure.

**NOTE** If the analyzer has Option PRC, Portable Configuration, and you want to remove the bail handle and bumpers from the front frame, refer to the “[Bail Handle Removal \(Option PRC\)](#)” section on [page 533](#).

---

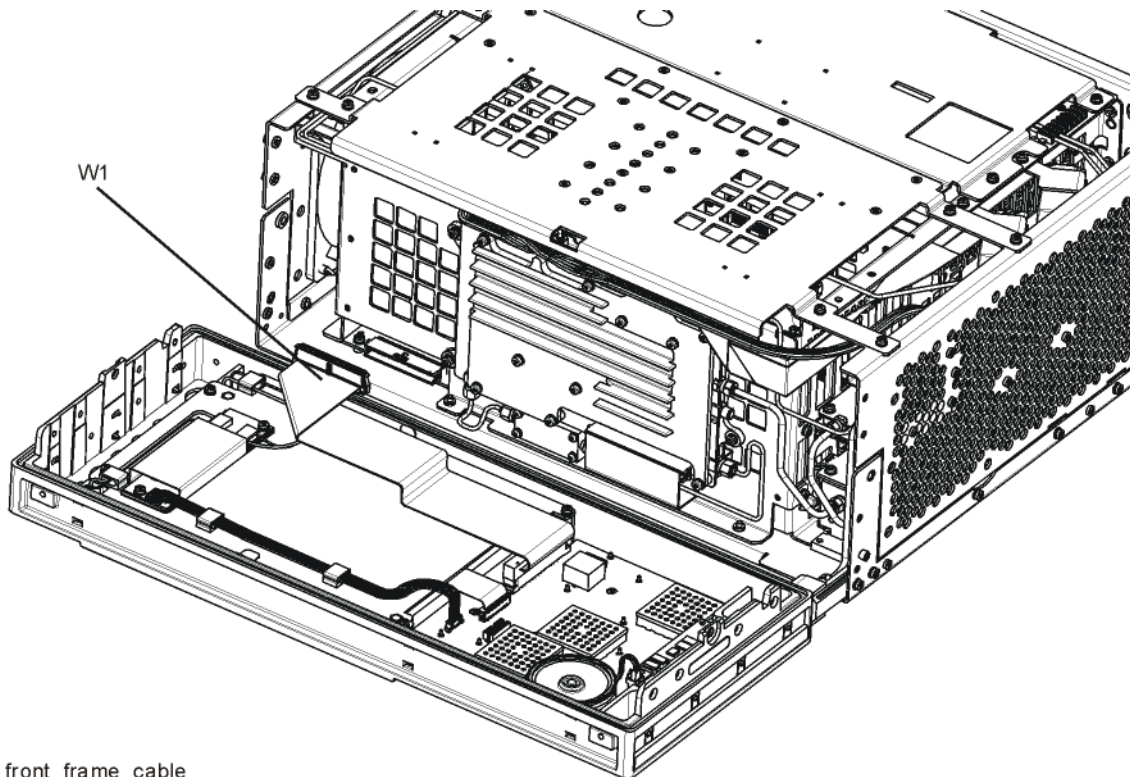
2. Refer to [Figure 14-76](#). Using the T-10 driver, remove the eight screws (1), four on each side, to detach the Front Frame Assembly from the chassis.

**Figure 14-76** Front Frame Assembly Removal



3. Refer to **Figure 14-77**. Pull the Front Frame Assembly carefully away from the chassis. Remove the ribbon cable W1 from the mother board.
4. If the instrument has Option BBA (BBIQ inputs), there will be an additional cable (W24) that will need to be removed. W24 connects to the A18 BBIQ Interface Board. Pull the Front Frame Assembly carefully away from the chassis. Remove the ribbon cable W1 from the mother board.

Figure 14-77 Front Panel Cable



front\_frame\_cable

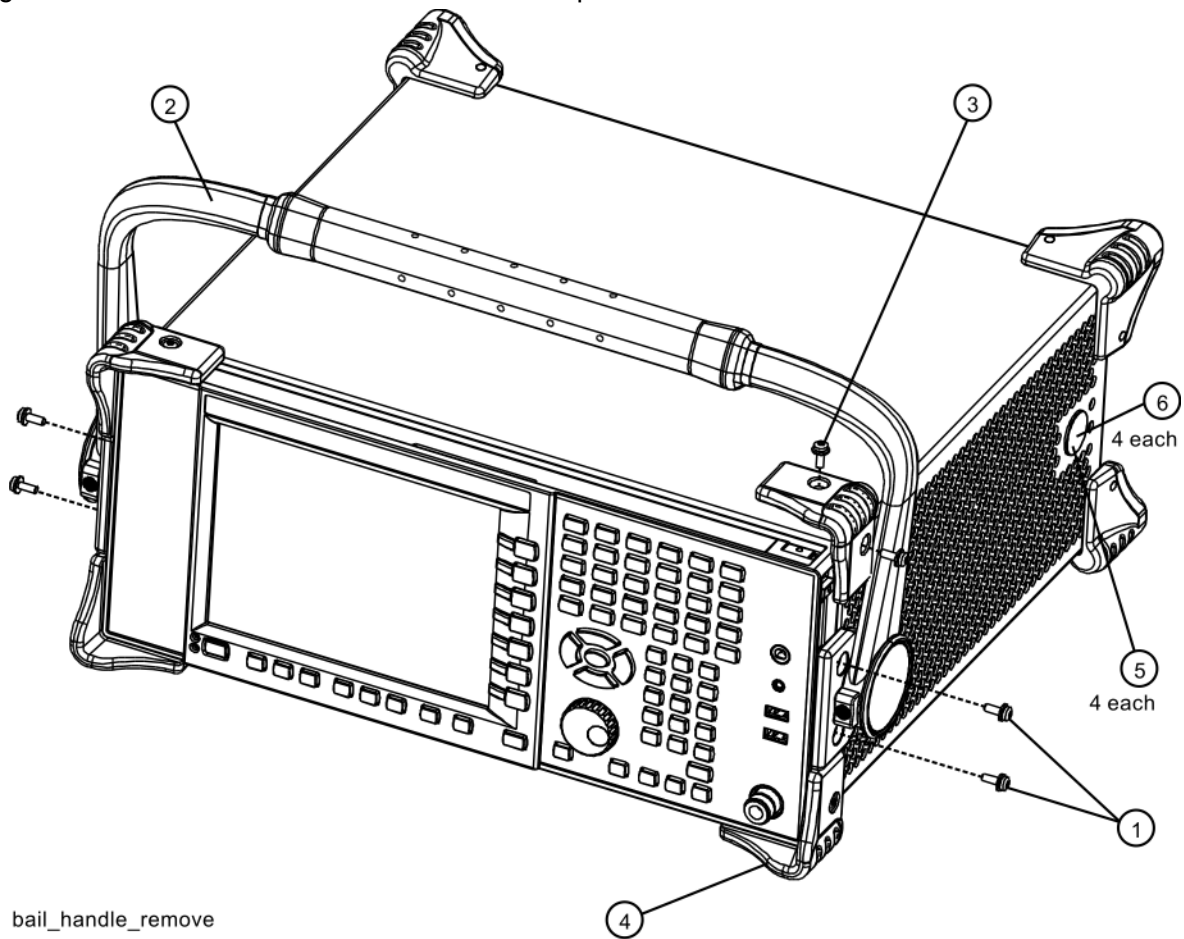
## Replacement

1. Reattach the ribbon cable W1.
2. Reattach the ribbon cable W24 for instruments with Option BBA.
3. Refer to **Figure 14-76**. Carefully position the Front Frame Assembly onto the chassis. Ensure no cables are crushed. Replace the eight screws (1), four on each side of the chassis. Torque to 9 inch pounds.
4. Replace the outer case. Refer to the Instrument Outer Casereplacement procedure.

### Bail Handle Removal (Option PRC)

1. Refer to **Figure 14-78**. Using the T-20 driver, remove the four screws (1), two on each side, to detach the Bail Handle Assembly (2) from the front frame.
2. Using the T-20 driver, remove the two screws (3) on each front bumper (4) and remove from the front frame.
3. When replacing these parts, torque to 21 inch-pounds.

Figure 14-78 Bail Handle and Front Bumpers Removal



bail\_handle\_remove

## Front Frame Assembly Components - LCD

**NOTE** Access to any of the Front Frame assemblies requires removal of the Front Frame Assembly from the chassis.

Figure 14-79 Front Frame Assembly Parts Locator - LCD

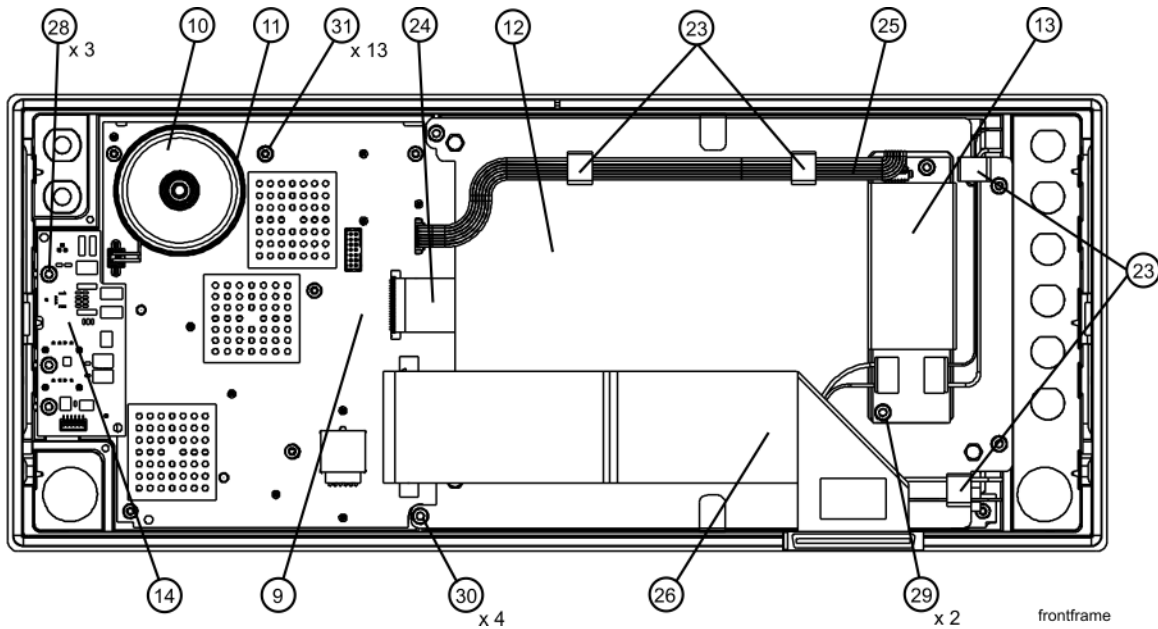
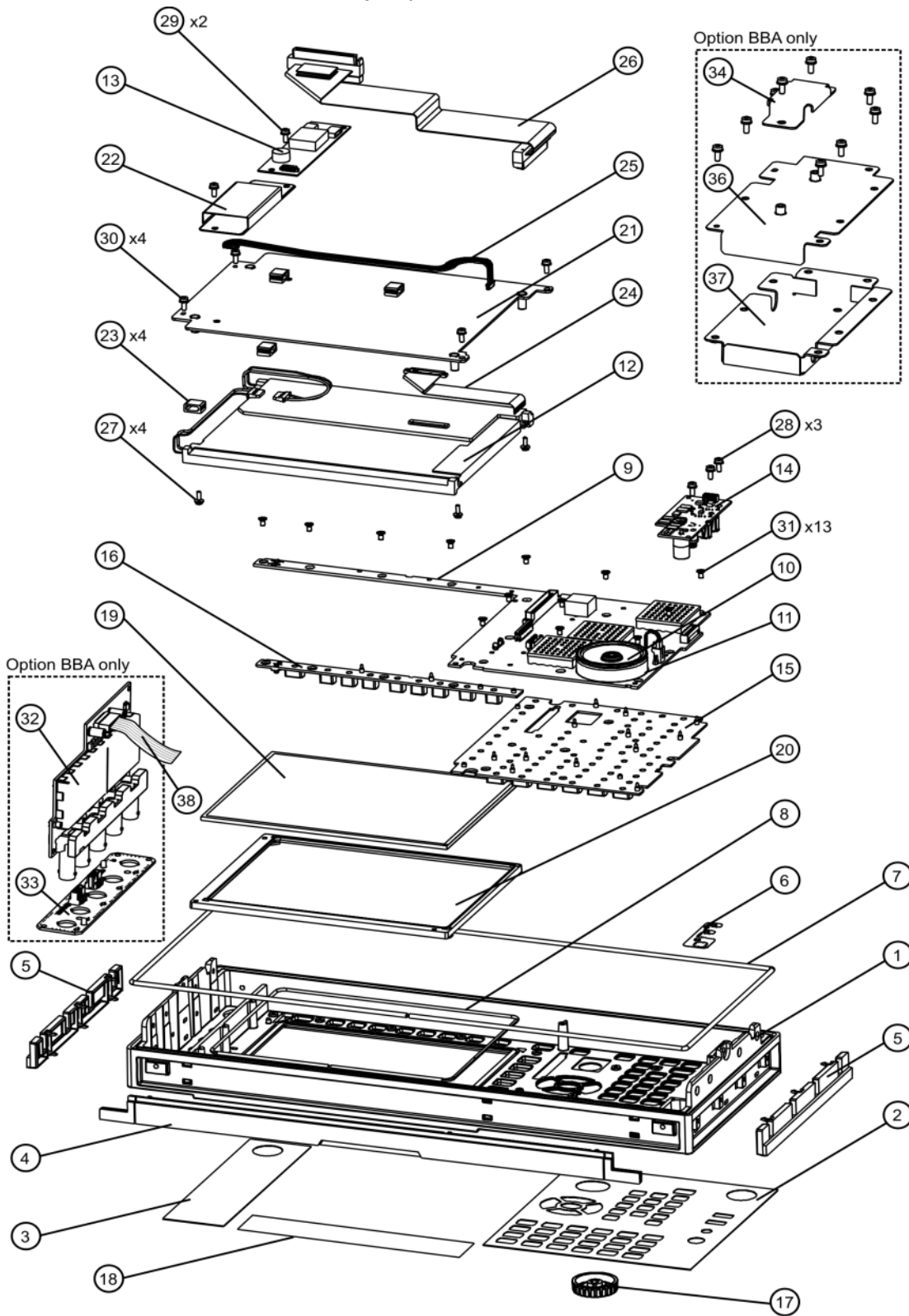


Table 14-3

Item	Reference Designator	Description
9	A1A2	Front Panel Interface Board
10	A1A2MP1	Speaker
11	A1A2MP2	Speaker Foam
12	A1A3	Liquid Crystal Display
13	A1A4	Inverter Board
14	A1A5	Front Panel Daughter Board
23	A1MP10-13	Cable Clamp (Front Panel Cables)
24	A1W1	Flex Circuit, Display to Front Panel Interface Board
25	A1W2	Power Cable, Front Panel Interface Board to Inverter Board
26	W1	Cable, Front Panel Interface Board to Motherboard (ribbon)
28, 29, 30	-	Screw - M3 X 8 mm (TORX Pan Head)
31	-	Screw - M3 X 5 mm (TORX Flat Head)

Figure 14-80

Front Frame Assembly Exploded View - LCD



Assembly Replacement Procedures  
Front Frame Assembly

Table 14-4

Item	Reference Designator	Description
1	A1A1	Front Frame
2	A1A1MP2	Main Keypad Overlay
3	A1A1MP3	Connector Overlay
4	A1A1MP7	Front Frame Top Trim Strip (use with standard Bench analyzer)
5	A1A1MP9-10	Front Frame Side Trim Strip
6	A1A1MP4	Front Frame Ground Spring
7	A1A1MP5	Braided Gasket
8	A1A1MP6	Chromatic Gasket
9	A1A2	Front Panel Interface Board
10	A1A2MP1	Speaker
11	A1A2MP2	Speaker Foam
12	A1A3	Liquid Crystal Display
13	A1A4	Inverter Board
14	A1A5	Front Panel Daughter Board
15	A1MP1	Main Keypad
16	A1MP2	Display Keypad
17	A1MP9	Knob
18	A1MP3 A1MP4 A1MP5 A1MP6	Frequency Label, 3.6 GHz Frequency Label, 8.4 GHz Frequency Label, 13.6 GHz Frequency Label, 26.5 GHz
19	A1MP7	LCD Glass Filter
20	A1MP8	LCD Lens Gasket
21	A1MP14	Display Bracket
22	A1MP15	Inverter Board Shield
23	A1MP10-13	Cable Clamp (Front Panel Cables)
24	A1W1	Flex Circuit, Display to Front Panel Interface Board
25	A1W2	Power Cable, Front Panel Interface Board to Inverter Board
26	W1	Cable, Front Panel Interface Board to Motherboard (ribbon)
27	-	Screw - M2.5 X 8 mm (TORX Pan Head)



Table 14-4

Item	Reference Designator	Description
28	-	Screw - M3 X 8 mm (TORX Pan Head)
29	-	Screw - M3 X 8 mm (TORX Pan Head)
30	-	Screw - M3 X 8 mm (TORX Pan Head)
31	-	Screw - M3 X 5 mm (TORX Flat Head)
32	A18	BBIQ Interface Board (Option BBA)
33	A17	BBIQ LED Board (Option BBA)
34	A1MP18	Core Bracket (Option BBA)
36	A1MP16	Inverter Top Shield (Option BBA)
37	A1MP17	Inverter Bottom Shield (Option BBA)
37	W24	Cable Assembly, A18J1, BBIQ Interface Board to A19J1, BBIQ Main Board (ribbon cable (Option BBA)

## Display Assembly - LCD

### Removal

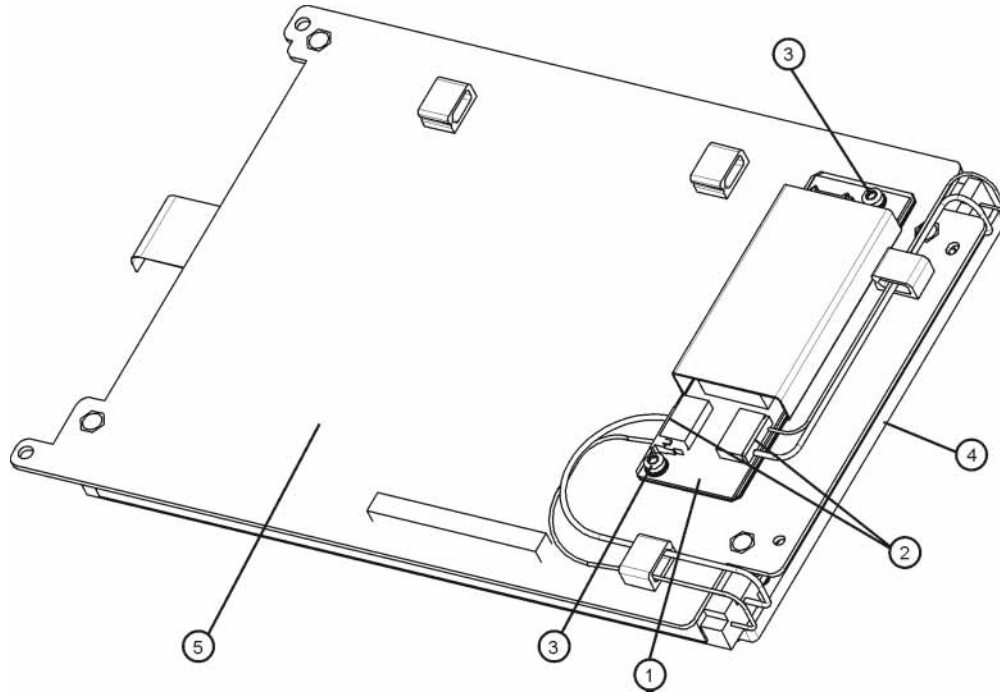
1. Refer to **Figure 14-79**. Ribbon cable W1 (26) must be separated from the display by pulling up to separate the velcro that is used to adhere the cable to the bracket.
2. Refer to **Figure 14-80**. Disconnect W24 (38) from A16 if Option BBA is installed in the instrument.
3. Refer to **Figure 14-79**. Disconnect the cable A1W2 (25) from the LCD Inverter board (13) and unclip the cable from the cable clamps.
4. Disconnect the flex circuit A1W1 (24) from the front panel interface board (9).
5. Remove the four screws (30) securing the display bracket (12) to the Front Frame Assembly. The display can now be removed from the Front Frame Assembly.

### CAUTION

Once the display assembly has been removed from the Front Frame Assembly, the glass filter is no longer secured. DO NOT tip the assembly in such a manner that would cause it to fall out of place, as this may cause injury and/or damage to the glass.

6. Refer to **Figure 14-81**. Disconnect the backlight wires (2) from the inverter board.

**Figure 14-81** Inverter Board Removal



7. To remove the A1A4 LCD Inverter board (1), remove the two screws (3) securing the inverter board to the display bracket (5).
8. To remove the A1A3 LCD (4), flip the assembly over and remove the four screws securing the LCD to the display bracket (5).

## Replacement

1. To replace the A1A3 LCD **(4)**, place it on the display bracket **(5)** and replace the four screws. Torque to 9 inch pounds.
2. To replace the A1A4 Inverter board **(1)**, place it on the display bracket **(5)** and replace the two screws **(3)**. Torque to 9 inch pounds.
3. Reattach the backlight wires **(2)** onto the inverter board.
4. Refer to **Figure 14-79**. Place the display bracket into position in the Front Frame Assembly. Reconnect the flex circuit A1W1 **(24)** to the front panel interface board **(9)**.
5. Replace the four screws **(30)** that secure the display bracket to the Front Frame Assembly. Torque to 9 inch pounds.
6. Reconnect the cable A1W2 **(25)** to the Inverter board **(13)**. Reclip the cable into the cable clamps.
7. Refer to **Figure 14-80**. Reconnect the cable W24 **(38)** of the instrument has Option BBA.
8. Adhere the velcro on ribbon cable W1 to the display.

## Daughter Board, Interface Board and Keypad

### Removal

1. Refer to **Figure 14-80**. Remove the knob **(17)** by carefully pulling it off.
2. Remove the display. Refer to the Display Assembly - LCDremoval procedure.
3. Refer to **Figure 14-79**. Remove the A1A5 Front Panel Daughter board **(14)** by removing the three screws **(28)** and unplugging it from the front panel interface board.
4. Remove the thirteen screws **(31)** securing the A1A2 Front Panel Interface board to the Front Frame Assembly. The Front Panel Interface board with the keypad attached can now be lifted from the Front Frame Assembly.
5. To separate the keypad from the Front Panel Interface board, use a push tool or pliers to carefully separate the pull through tabs.

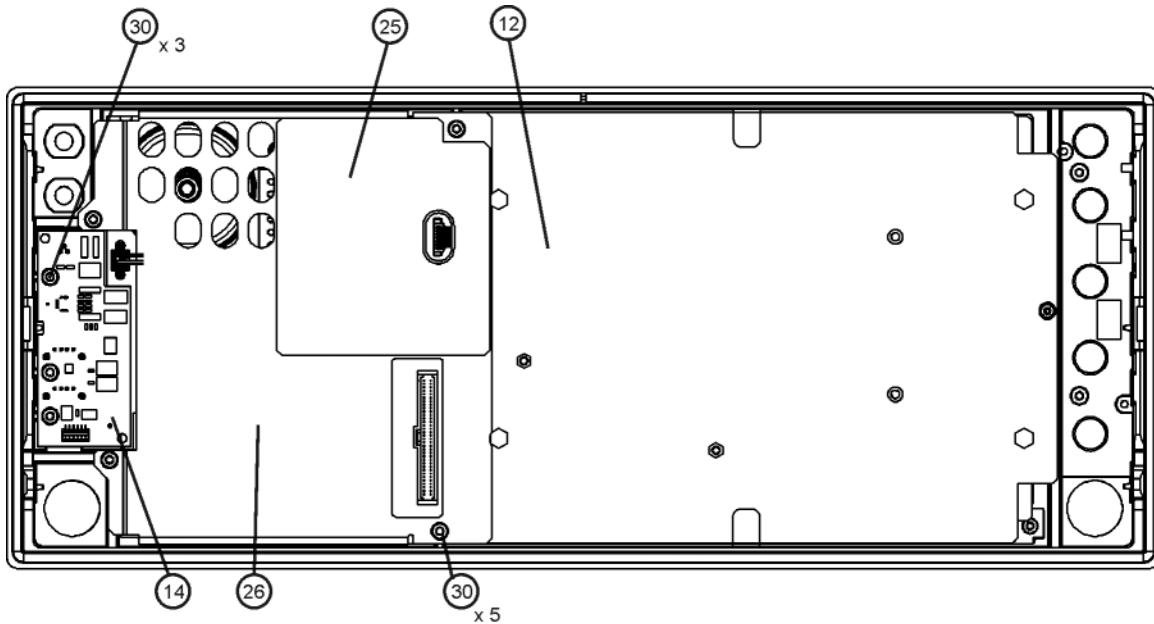
### Replacement

1. Install the keypad onto the Front Panel Interface board using the pull through tabs and alignment holes. Use a push tool or pliers to ensure that all of the pull through tabs are properly captive on the board.
2. Install the A1A2 Front Panel Interface board/keypad assembly into the Front Frame Assembly, and replace the thirteen screws **(31)** to secure. Torque to 9 inch pounds.
3. Replace the A1A5 Front Panel Daughter board **(14)** by plugging it into the Front Panel Interface board using the board to board connectors and secure it with the three screws **(28)**. Torque to 9 inch pounds.
4. Replace the display. Refer to the Display Assembly - LCDreplacement procedure.
5. Replace the knob by firmly pressing it on.

## Front Frame Assembly Components - LED

**NOTE** Access to any of the Front Frame assemblies requires removal of the Front Frame Assembly from the chassis.

Figure 14-82 Front Frame Parts - LED



frontframe\_LED

Table 14-5

Item	Description
12	A1MP14 Display Bracket
14	A1A5 Front Panel Daughter Board
25	A1MP24 Magnetic Shield (Display Bracket to Front Panel Interface/Speaker Bracket)
26	A1MP23 Front Panel Interface/Speaker Bracket
30	Screw, Front Panel Daughter Board()

Figure 14-83 Front Frame Parts (shields off) - LED

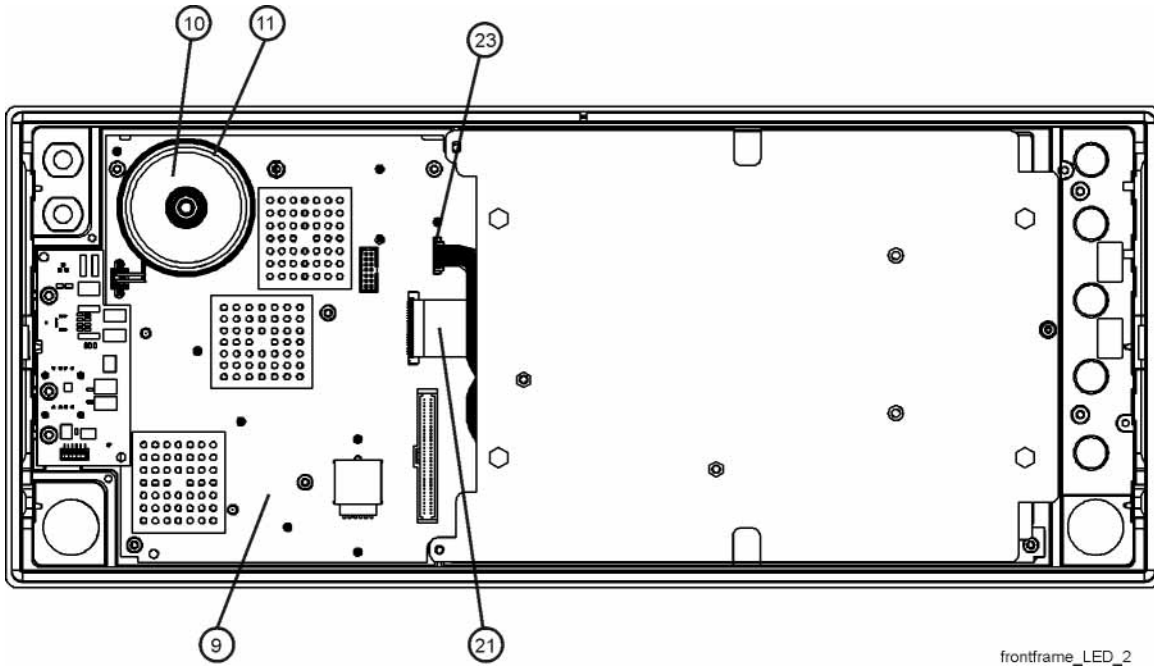
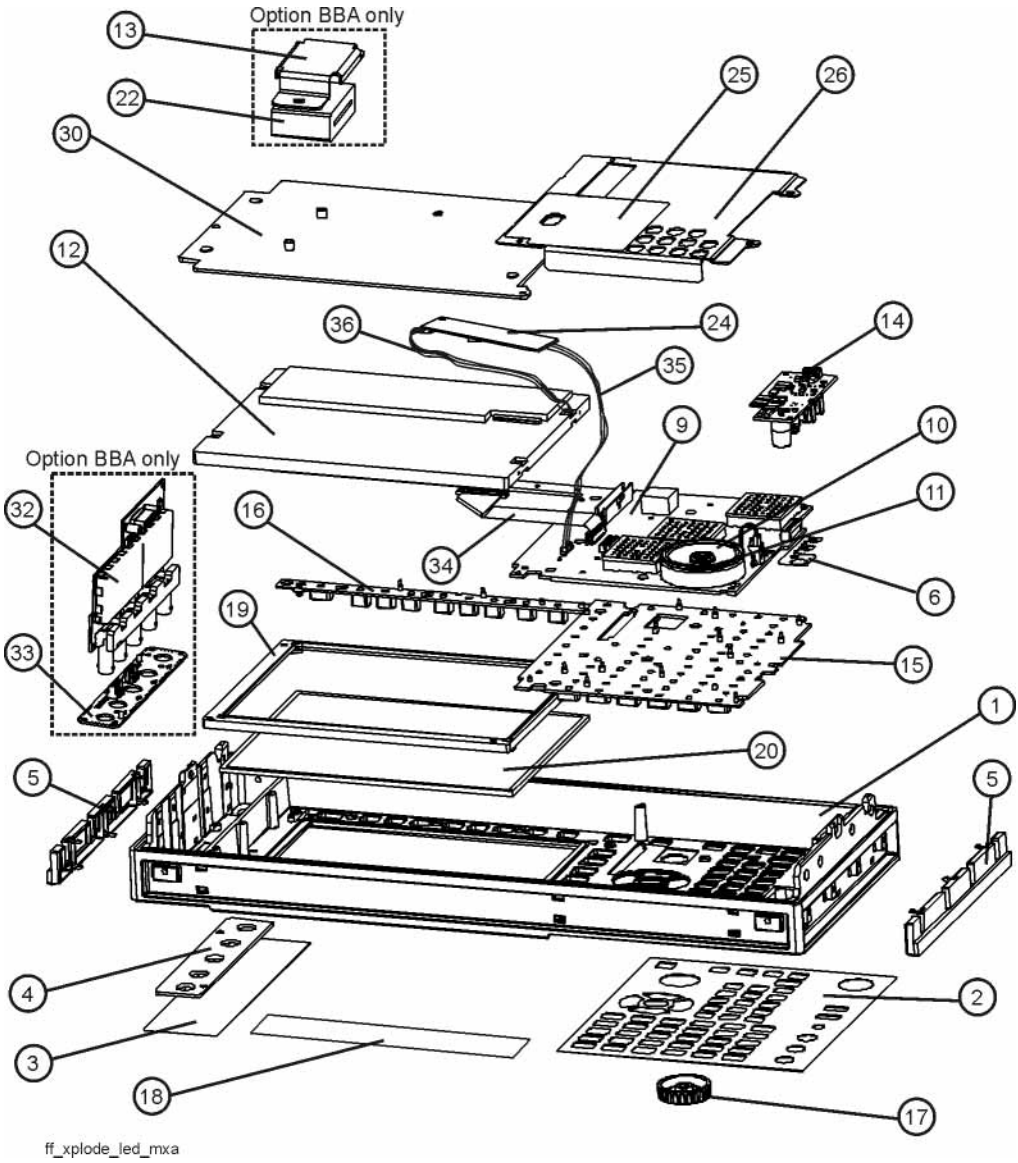


Table 14-6

Item	Description
9	A1A2 Front Panel Interface Board
10	A1A2MP1 Speaker
11	A1A2MP2 Speaker Foam
21	A1W1 Flex Circuit, Display to Front Panel Interface Board
23	A1W3 Power Cable, Front Panel Interface Board to DC-DC Converter

Figure 14-84 Front Frame Exploded View - LED



Assembly Replacement Procedures  
Front Frame Assembly

Table 14-7

Item	Description
1	Front Frame
2	Main Keyboard Overlay
3	Overlay, Left Display
4	Cover Plate
5	Front Frame Side Trim Strip (plastic)
6	Front Frame Ground Spring
9	A1A2 Front Panel Interface Board
10	A1A2MP1 Speaker
11	A1A2MP2 Speaker Foam
12	A1A3 Liquid Crystal Display
13	Vibration Mount
14	A1A5 Front Panel Daughter Board
15	A1MP1 Main Keypad
16	A1MP2 Display Keypad
17	A1MP9 Knob
18	A1MP3-6 Frequency Label
19	A1MP8 LCD Lens Gasket
20	A1MP7 LCD Glass Filter
22	A1MP18 Core Bracket (Option BBA)
24	A1A4 DC-DC Converter (LED display backlight power)
25	A1MP24 Magnetic Shield (Display Bracket to Front Panel Interface/Speaker Bracket)
26	A1MP23 Front Panel Interface/Speaker Bracket
30	A1MP14 Display Bracket
32	A18 BBIQ Interface Board (Option BBA)
33	A17 BBIQ LED Board (Option BBA)
34	A1W1 Flex Circuit, Display to Front Panel Interface Board
35	A1W3 Power Cable, Front Panel Interface Board to DC-DC Converter
36	A1W4 Power Cable, DC-DC Converter to Display



Figure 14-85 Front Frame Assembly Shields - LED

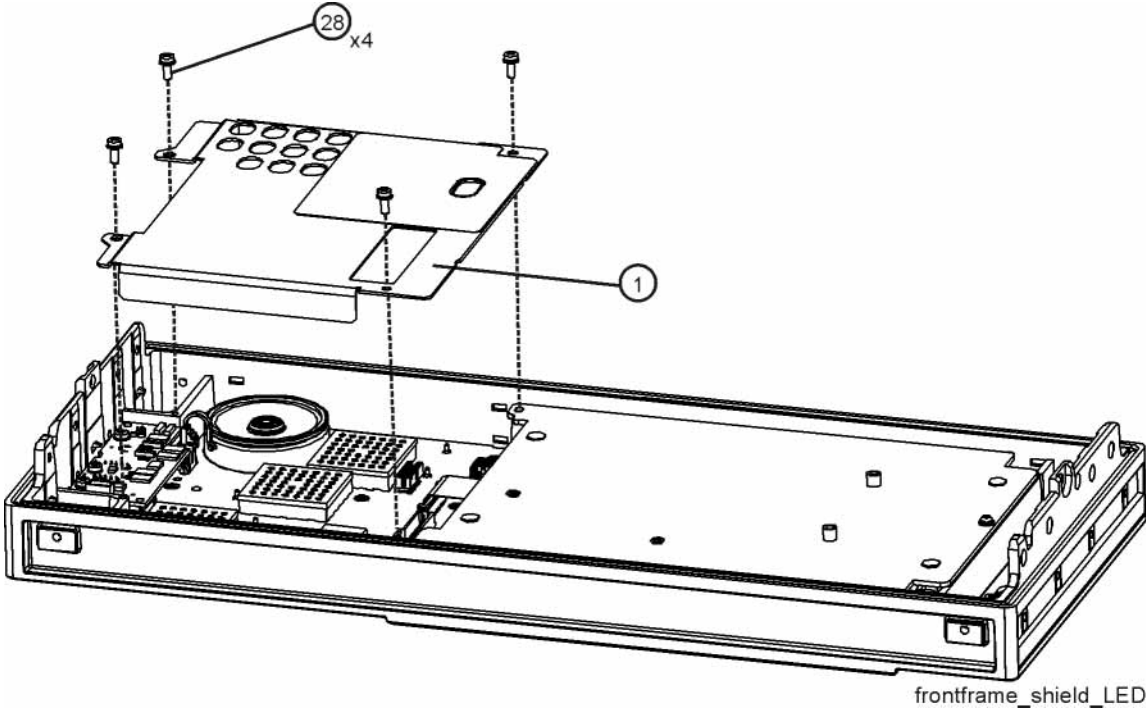


Table 14-8

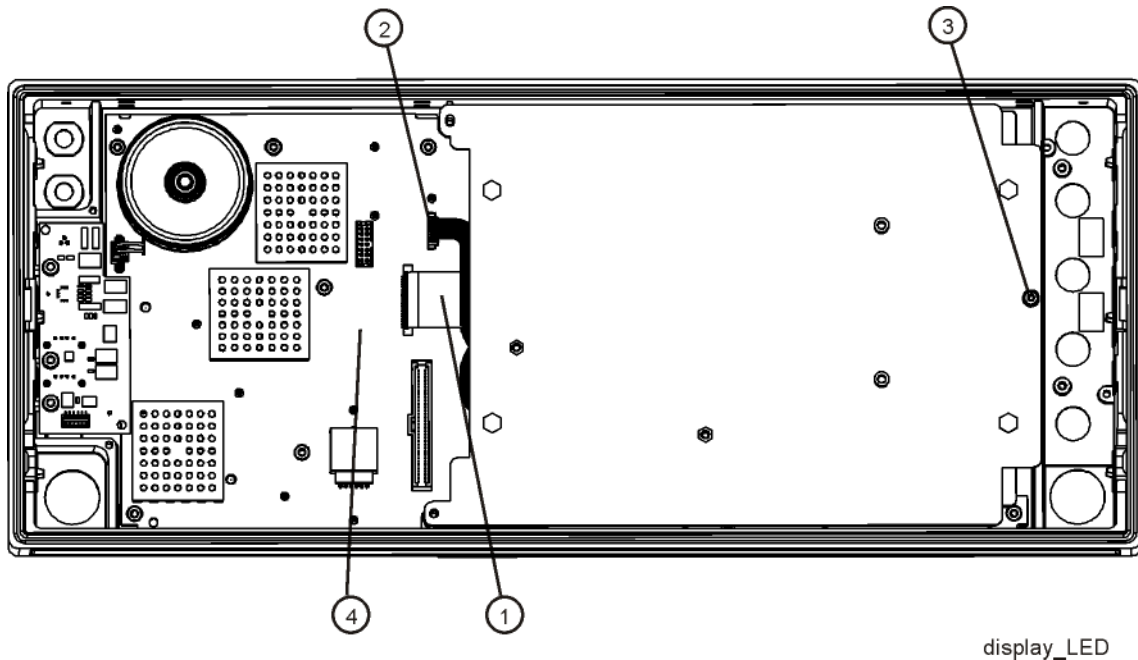
Item	Description
1	A1MP23 Front Panel Interface/Speaker Bracket
28	Screw M3 X 0.5 (5mm long) (0515-0372)

## Display Assembly - LED

### Removal

1. Refer to **Figure 14-85**. Remove the front panel shield by removing the four screws (28).
2. Refer to **Figure 14-86**. Disconnect the flex circuit A1W1 (1) and A1W3 (2) from the front panel interface board (4).

**Figure 14-86** Display Removal - LED



display\_LED

3. Remove the screw (3) securing the display bracket to the Front Frame Assembly. The display can now be removed from the Front Frame Assembly.

### CAUTION

Once the display assembly has been removed from the Front Frame Assembly, the glass filter is no longer secured. DO NOT tip the assembly in such a manner that would cause it to fall out of place, as this may cause injury and/or damage to the glass.

4. Refer to **Figure 14-87**. To separate the LCD (2) from the display bracket (1), remove the four screws (3). When reassembling, torque the four screws to 5 inch-pounds.



## Daughter Board, Interface Board and Keypad

### Removal

1. Refer to **Figure 14-84**. Remove the knob **(17)** by carefully pulling it off.
2. Remove the display. Refer to the Display Assembly - LEDremoval procedure.
3. Refer to **Figure 14-82**. Remove the A1A5 Front Panel Daughter board **(14)** by removing the three screws **(30)** and unplugging it from the front panel interface board.
4. Remove the thirteen screws securing the A1A2 Front Panel Interface board to the Front Frame Assembly. The Front Panel Interface board with the keypad attached can now be lifted from the Front Frame Assembly.
5. To separate the keypad from the Front Panel Interface board, use a push tool or pliers to carefully separate the pull through tabs.

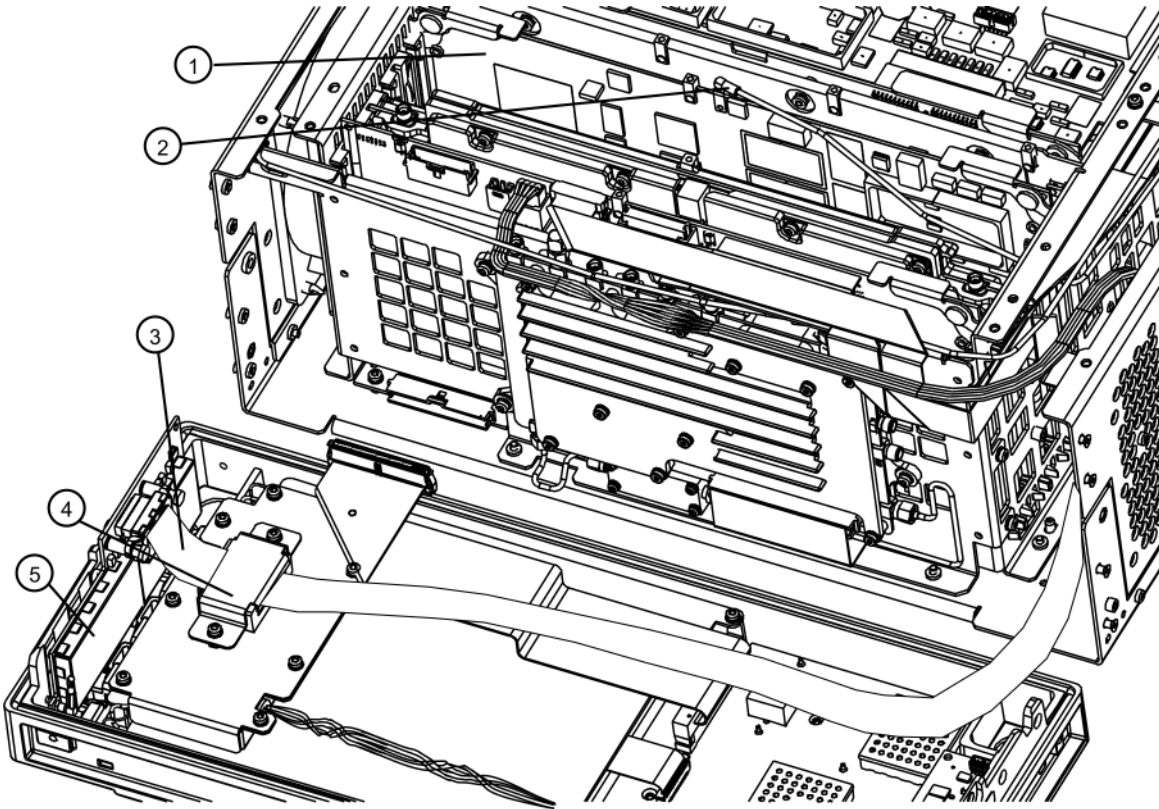
### Replacement

1. Install the keypad onto the Front Panel Interface board using the pull through tabs and alignment holes. Use a push tool or pliers to ensure that all of the pull through tabs are properly captive on the board.
2. Install the A1A2 Front Panel Interface board/keypad assembly into the Front Frame Assembly, and replace the thirteen screws to secure. Torque to 9 inch-pounds.
3. Replace the A1A5 Front Panel Daughter board **(14)** by plugging it into the Front Panel Interface board using the board to board connectors and secure it with the three screws **(30)**. Torque to 9 inch-pounds.
4. Replace the display. Refer to the Display Assembly - LCDreplacement procedure.
5. Replace the knob by firmly pressing it on.

## Option BBA

**NOTE** Access to any of the Option BBA Front Frame assemblies requires removal of the Front Frame Assembly from the chassis.

Figure 14-88 Option BBA Parts Locator



bbiq\_parts1  
Table 14-9

Item	Reference Designator	Description
1	A19	BBIQ Main Board (Option BBA)
2	W25	Cable Assembly, A19J101, BBIQ Main Board to A16J707 Reference Board (Flexible Coax) (Option BBA)
3	W24	Cable Assembly, A18J1, BBIQ Interface Board to A19J1, BBIQ Main Board (Ribbon Cable) (Option BBA)
4	A1MP18	Core Bracket (Option BBA)
5	A18	BBIQ Interface Board (Option BBA)

## Inverter Board

### Removal

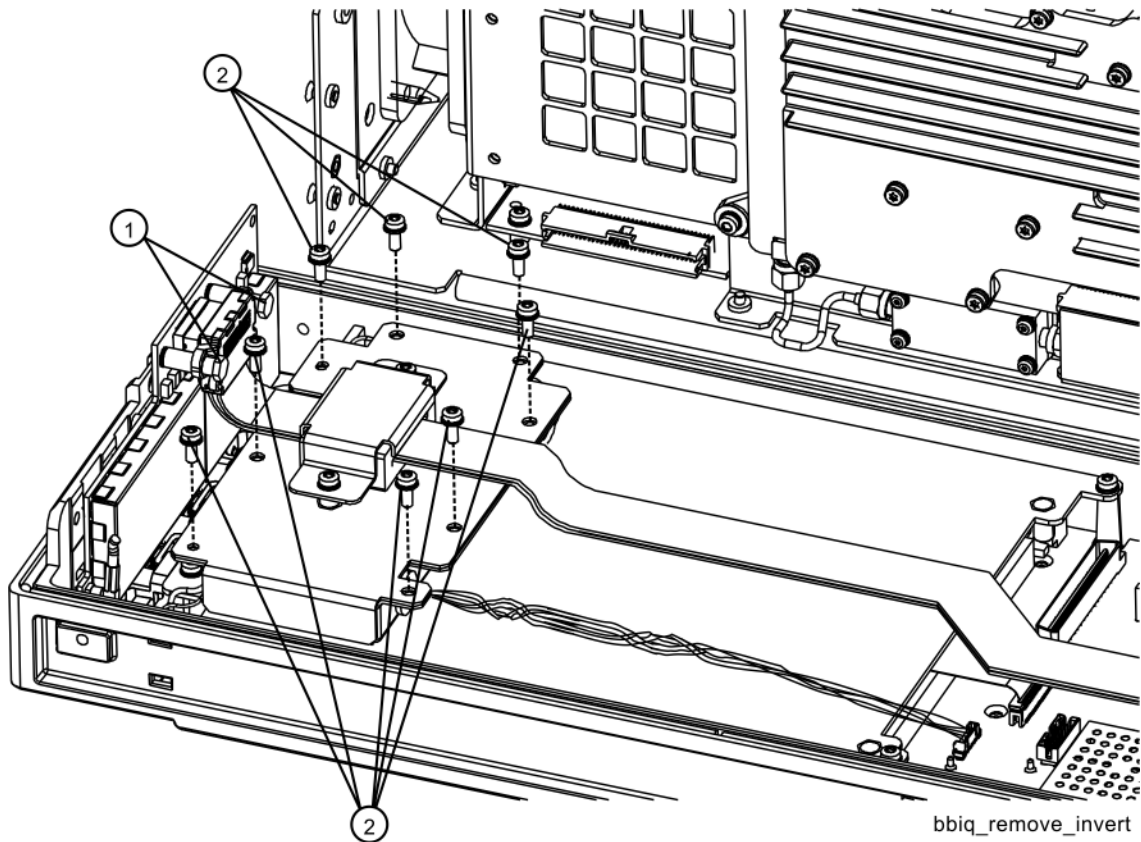
1. Refer to **Figure 14-89**. Using a ¼-inch socket remove the two Hex screws (1) that secure the flex ribbon into the connector.

**NOTE** The flex ribbon cannot have tight radial bends as this will damage the cable.

---

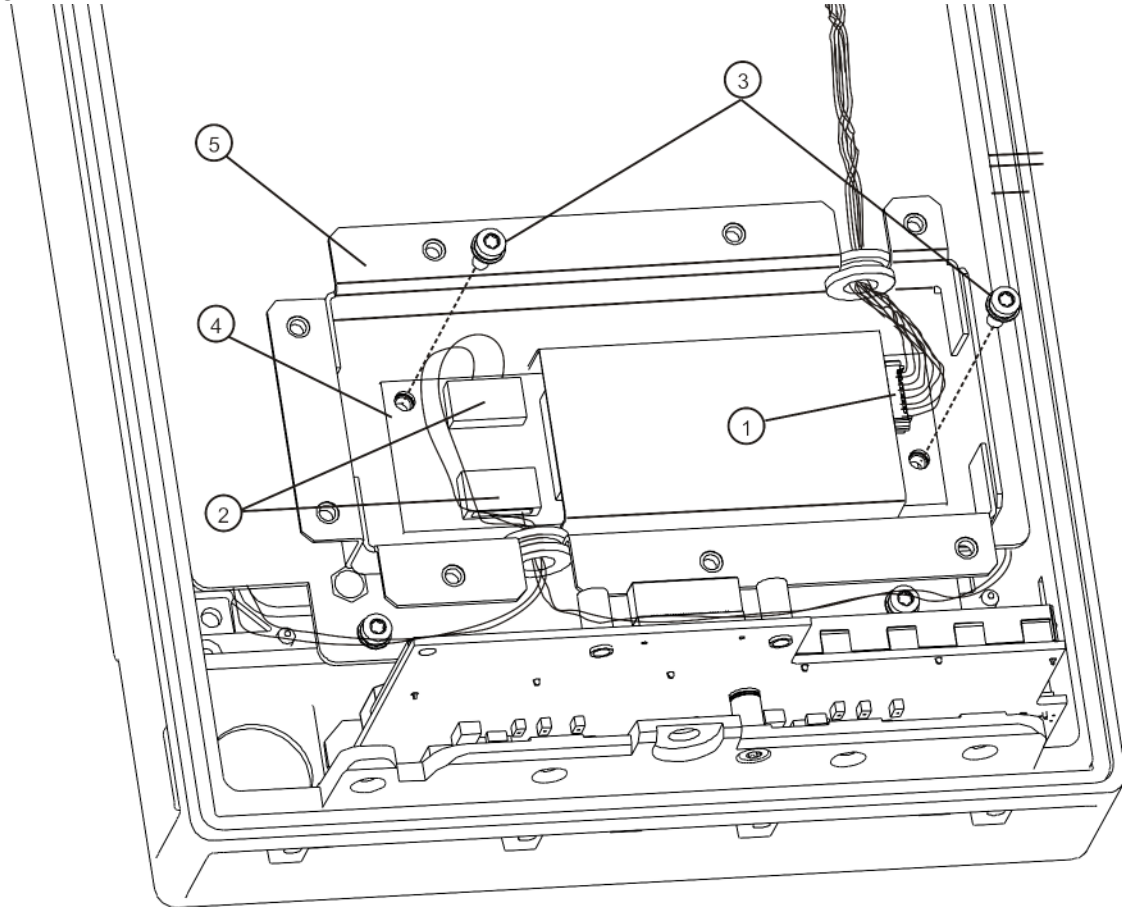
2. Remove the eight screws (2) that secure the inverter top shield to the bottom shield. Carefully remove the top shield with the ribbon cable attached

**Figure 14-89** Inverter Top Shield Removal



3. Refer to **Figure 14-90**. Disconnect the cable (1) and backlight wires (2) from the inverter board. Remove the two screws (3) that secure the inverter board (4) and bottom shield (5) to the display assembly. Carefully remove the inverter board.

**Figure 14-90** Inverter Board and Bottom Shield Removal



bbiq\_remove\_invert2

### Replacement

1. Refer to **Figure 14-90**. To replace the inverter board (4), place it in the bottom shield (5) on the display bracket. Line up the holes in the shield base and PC assembly with front frame assembly. Replace the two screws (3). Torque to 9 inch pounds.
2. Reconnect the cable (1) and backlight wires (2) to the inverter board.
3. Fit grommets inside the wire access slots if they were dislodged.
4. Refer to **Figure 14-89**. Align the top inverter shield (1) with holes in bottom as shown.

5. Inspect to see that the wires are not pinched in both places where the wires go through the holes.
6. Replace the eight screws **(2)** to secure the inverter top shield to the bottom shield. Torque to 9 in-lbs.
7. Carefully reconnect the ribbon to the BBIQ Interface board. Install two Hex screws **(1)** to secure the flex ribbon into the connector. Torque to 4 in-lbs with the ¼-inch socket.

### BBIQ Interface Board, LED Board, and Overlay

#### Removal

1. Refer to **Figure 14-91**. Using a ¼-inch socket remove the two Hex screws **(1)** that secure the flex ribbon into the connector.

---

**NOTE**

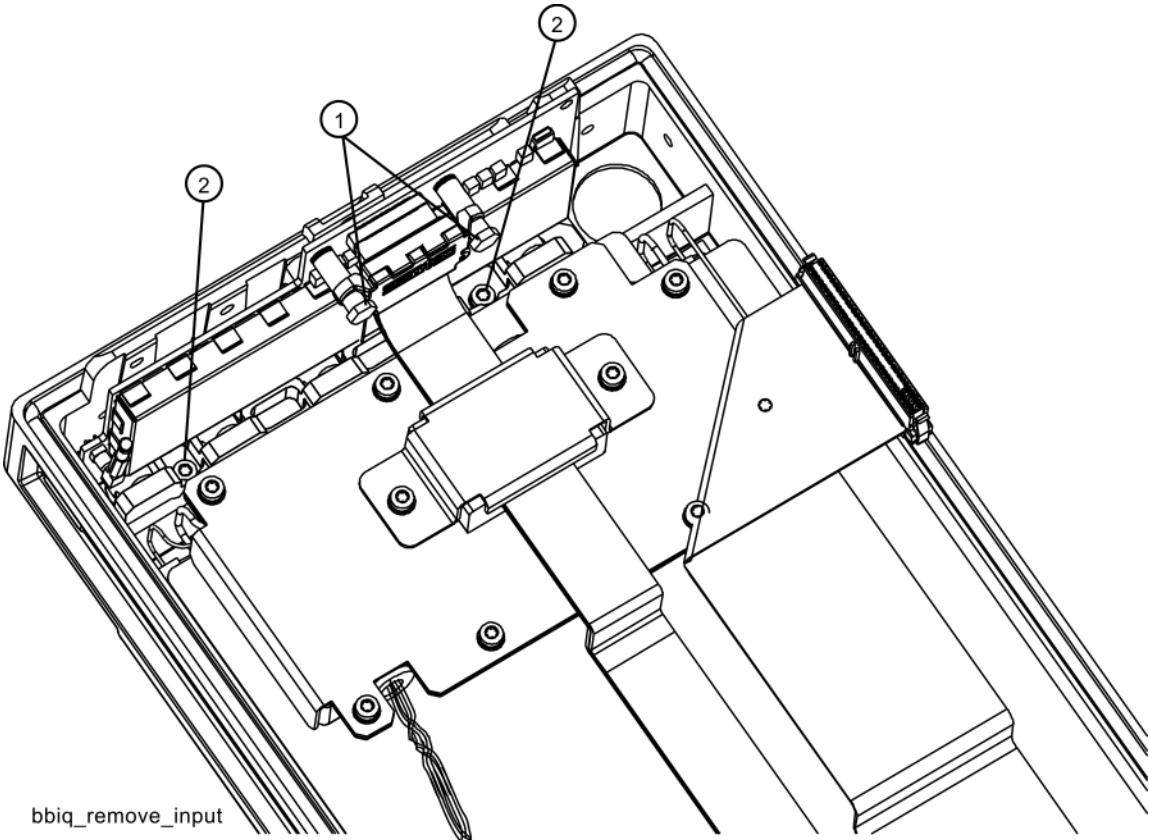
The flex ribbon cannot have tight radial bends as this will damage the cable.

---

2. Remove the two screws **(2)** attaching the BBIQ Interface board to the front frame.

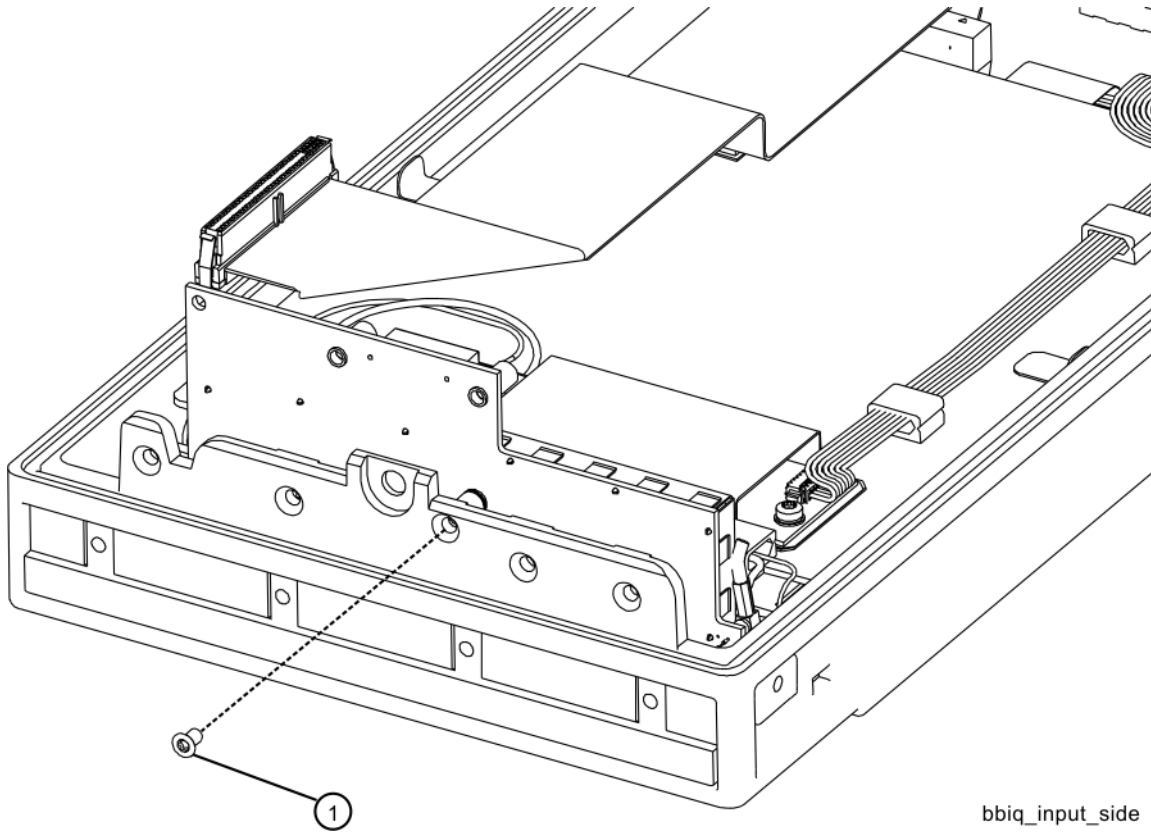


**Figure 14-91** BBIQ Interface Board Removal



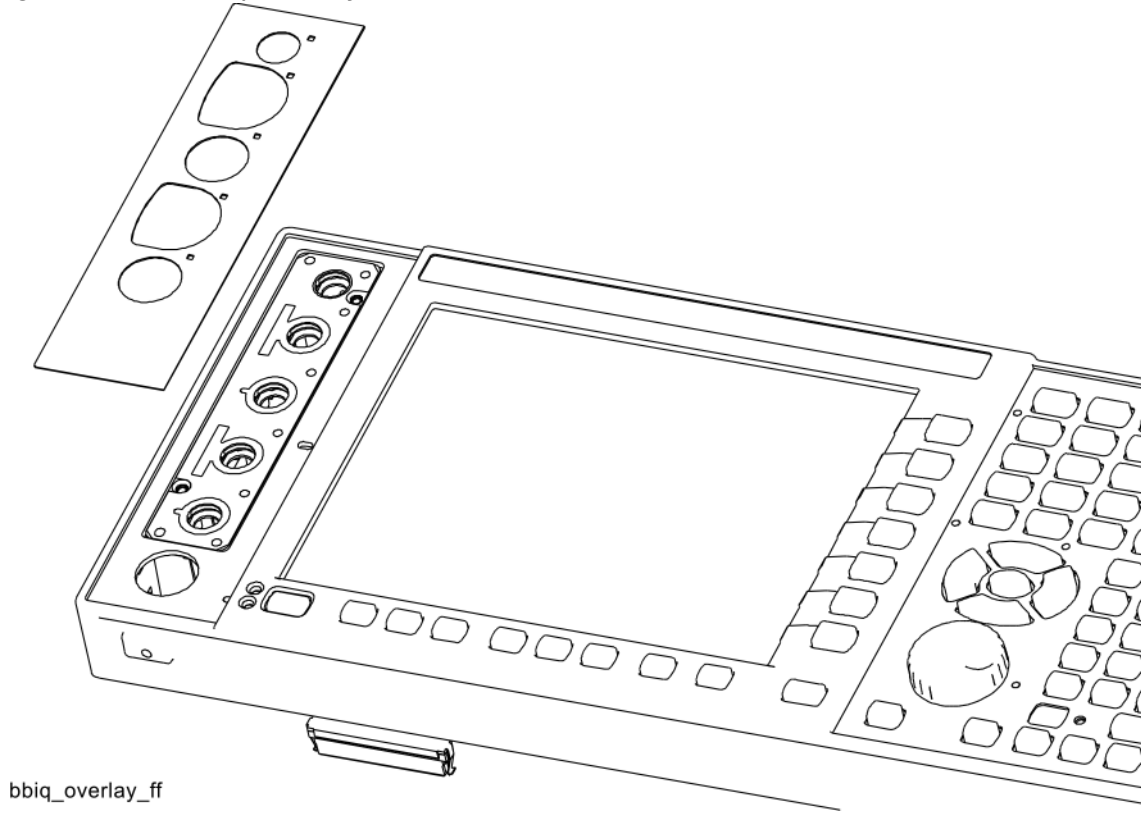
3. Refer to **Figure 14-92**. Remove the side screw (1) attaching the BBIQ Interface board to the front frame.

**Figure 14-92** BBIQ Interface Board Side Screw



4. Refer to **Figure 14-93**. Carefully pry up the top overlay to separate it from the LED board.

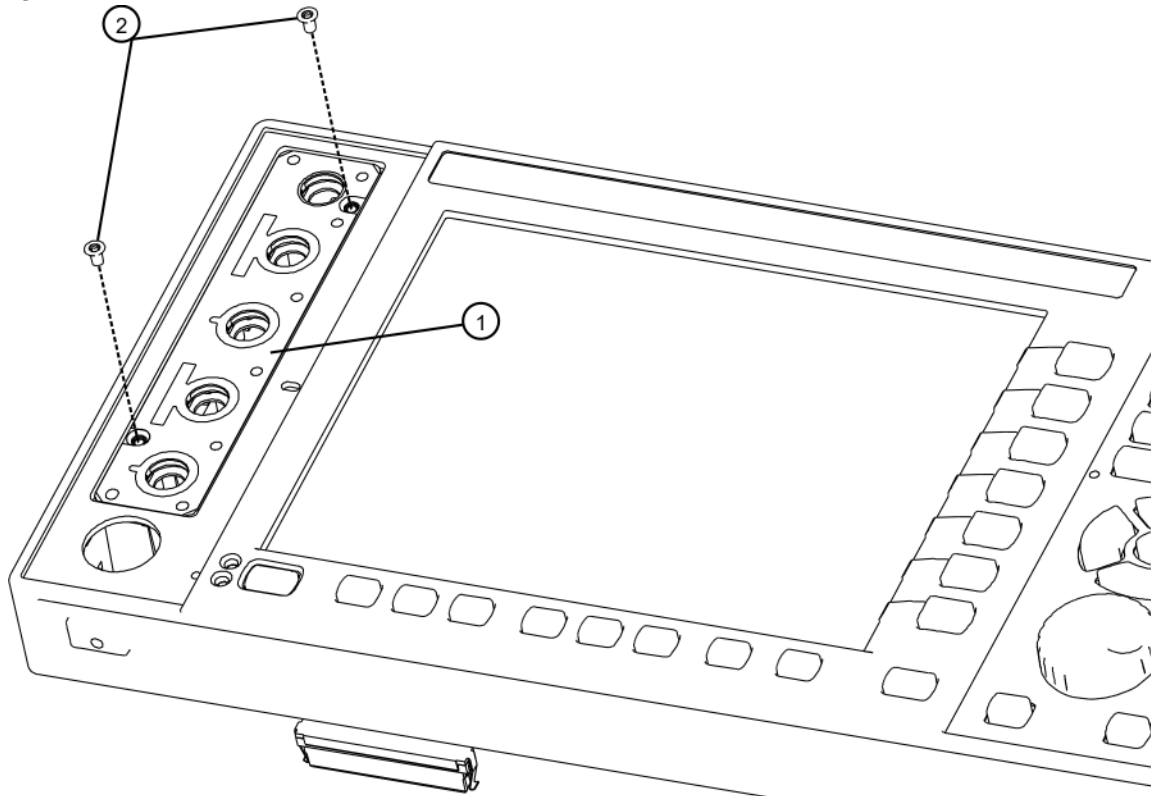
**Figure 14-93** Top Overlay Removal



bbiq\_overlay\_ff

5. Refer to **Figure 14-94**. Remove the two screws (**2**) attaching the LED board and bottom overlay to the front frame assembly.

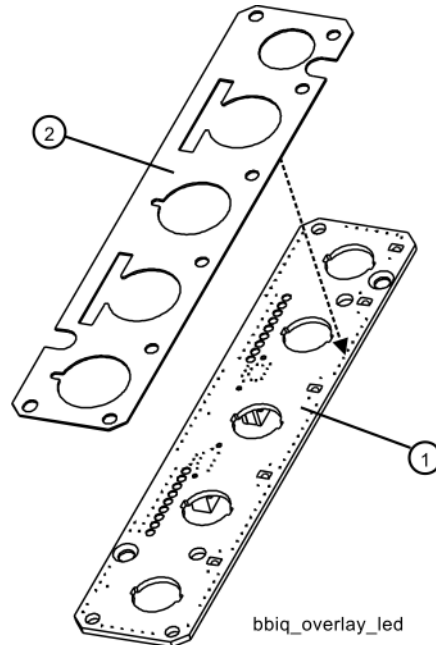
**Figure 14-94** LED Board Installation



bbiq\_led\_ff

6. Refer to **Figure 14-95**. The LED board (1) can now be separated from the LED board overlay (2).

**Figure 14-95** LED Board and Overlay



### Replacement

1. Refer to **Figure 14-95**. Line up the holes and carefully attach the overlay (2) to the LED board (1).
2. Refer to **Figure 14-94**. Install the LED board with overlay attached into the front frame.
3. Secure the LED board with two screws (2). Torque to 9 in-lbs.
4. Refer to **Figure 14-91**. Install the BBIQ Interface board, into the front frame passing the BNC connectors through the holes. Secure the board with two screws (2). Torque to 9 in-lbs.
5. Reconnect the ribbon cable to the connector on the BBIQ Interface board. Using a 1/4-inch socket reinstall the two Hex screws (1) that secure the flex ribbon into the connector. Torque to 4 in-lbs.
6. Refer to **Figure 14-92**. Secure the BBIQ Interface board to the side of the front frame with a single screw (1). Torque to 9 in-lbs.
7. Refer to **Figure 14-93**. Line up and carefully attach the top overlay over the lower overlay.
8. Press firmly down over the entire surface area of the top overlay.

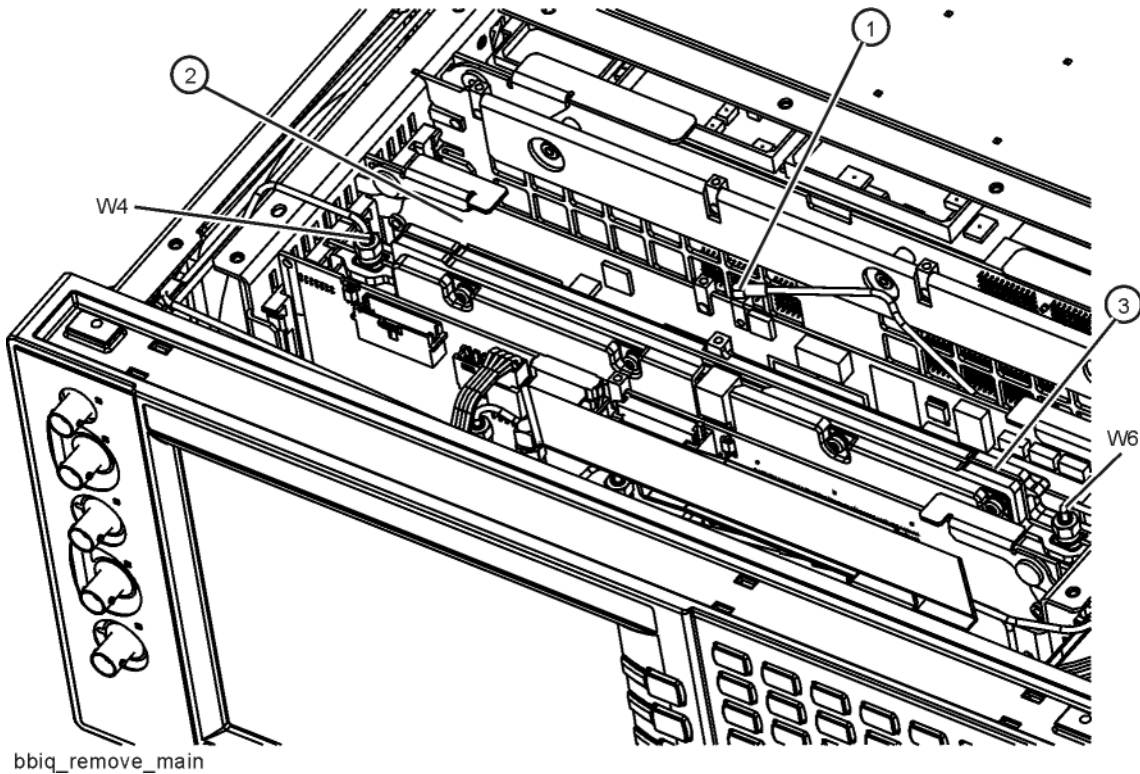
## BBIQ Main Board

### Removal

1. Refer to **Figure 14-96**. Remove W4 and W6 from the A14 L.O. Synthesizer board. Lift and remove the A14 (3) from the instrument. Remove the coax cable (1) and the ribbon cable (along the side of the board) first before lifting the board extractors to remove the A19 BBIQ Main board (2). Otherwise damage to the ribbon cable will occur.

**NOTE** The flex ribbon cannot have tight radial bends as this will damage the cable.

**Figure 14-96** BBIQ Main Board Removal



### Replacement

1. Refer to **Figure 14-96**. Install the A19 BBIQ Main board into slot 4 and use the board extractors to secure the board into the motherboard connectors. Reattach the coax cable (1). Carefully route the ribbon cable through the

chassis side wall and gently press the cable into place until it snaps into the A19J1 connector off the BBIQ Main board. Re-install the A14 L.O. Synthesizer board and re-attach W4 and W6 cables.

Assembly Replacement Procedures  
Front Frame Assembly



## 15 Post-Repair Procedures

### What You Will Find in This Chapter

This chapter provides information that will enable you to return an instrument to full operation following the replacement of any instrument assembly. This information includes a table that shows which adjustments and/or performance tests must be executed after replacing an assembly.

#### Before Starting

There are three things you should do before starting any of the procedures listed or described in this chapter:

- Familiarize yourself with the safety symbols, and read the general safety considerations and the safety note definitions in the front of this guide, **before** you begin the procedures in this chapter.
- Check that the analyzer has been turned on and allowed to warm up.
- Ensure that the analyzer is operating within a temperature range of 20 °C to 30 °C.

#### Test equipment you will need

Refer to [Table 1-1 on page 26](#), for a list of recommended equipment and critical test equipment specifications for the performance verification and adjustments.

## Post-Repair Procedures

**Table 15-1** lists the adjustments and performance verification tests needed after an assembly replacement.

After an assembly is replaced, find the assembly that has been replaced in the left-hand column, and then perform the recommended adjustment and/or performance verification test. Making the recommended adjustments and/or performance verification tests doesn't guarantee all published specifications are being met. Only a full instrument calibration will do this.

### NOTE

Refer to the analyzer user's guide for information on instrument warm-up before performing any of the procedures listed in this chapter.

---

The following procedures are also included in the **"Additional Tasks" on page 567**.

- **"Calibration Data Backup and Restore"**
- **"BIOS Settings Verification"**
- **"End User License Agreement (EULA) Acceptance (Software versions  $\leq$  A.06.08)"**
- **"End User License Agreement (EULA) Acceptance (Software versions  $\geq$  A.07.00)"**
- **"FPGA Synchronization"**
- **"Programming Model and Serial Numbers"**

Table 15-1 Post-Repair Testing Requirements

Assembly	Adjustments to Perform (in the order listed) <sup>a</sup>	Performance Verifications to Perform After Adjustments <sup>a</sup>
<b>A1A2</b> Front Panel Interface	None	Residual Responses Displayed Average Noise Level
<b>A1A3</b> Liquid Crystal Display	None	Residual Responses Displayed Average Noise Level
<b>A2</b> Analog I.F. Assembly	IF Frequency Response <sup>b</sup>	Power Bandwidth Accuracy Resolution Bandwidth Switching Uncertainty Residual Responses Displayed Average Noise Level I.F. Frequency Response Absolute Amplitude Accuracy Display Scale Fidelity
<b>A3</b> Digital I.F. Assembly	FPGA Synchronization <sup>c</sup>	Power Bandwidth Accuracy Resolution Bandwidth Switching Uncertainty Residual Responses Displayed Average Noise Level I.F. Frequency Response Absolute Amplitude Accuracy Display Scale Fidelity
<b>A4</b> CPU Assembly	BIOS Settings Verification <sup>c</sup> Set Instrument Time and Date <sup>d</sup>	Residual Responses Displayed Average Noise Level
<b>A4BT1</b> Battery	BIOS Settings Verification <sup>c</sup> Set Instrument Time and Date <sup>d</sup>	Residual Responses Displayed Average Noise Level
<b>A5</b> Disk Drive <sup>e</sup>	Accept End User License Agreement (EULA) <sup>c</sup> Instrument Software Update <sup>f</sup> All Adjustments <sup>e</sup>	Residual Responses Displayed Average Noise Level Frequency Response (All Tests)
<b>A6</b> Power Supply	None	Residual Responses Displayed Average Noise Level Spurious Responses
<b>A7</b> Midplane board	None	Residual Responses Displayed Average Noise Level
<b>A8</b> Motherboard	None	Residual Responses Displayed Average Noise Level

Table 15-1 Post-Repair Testing Requirements (Continued)

Assembly	Adjustments to Perform (in the order listed) <sup>a</sup>	Performance Verifications to Perform After Adjustments <sup>a</sup>
<b>A9 &amp; A10</b> RF Attenuators	Hardware Statistical Reset Utility 50 MHz Calibrator Adjustment Frequency Response (All Adjustments) Attenuator Slope	Residual Responses Displayed Average Noise Level Spurious Responses Third Order Intermodulation Absolute Amplitude Accuracy Input Attenuation Switching Uncertainty Frequency Response (All Tests)
<b>A11</b> Low Band Switch	Frequency Response (All Tests) Attenuator Slope	Residual Responses Displayed Average Noise Level Spurious Responses Third Order Intermodulation Second Harmonic Distortion Absolute Amplitude Accuracy Frequency Response (All Tests)
<b>A12</b> YTF Preselector	YTF Alignment (Press <b>System, Alignments, Advanced, Characterize Preselector</b> ) Frequency Response (All Adjustments) Attenuator Slope	Residual Responses Displayed Average Noise Level Spurious Responses Third Order Intermodulation Second Harmonic Distortion Absolute Amplitude Accuracy Frequency Response (All Tests)
<b>A13</b> Front End Assembly	Frequency Response (All Tests) Attenuator Slope	Residual Responses Displayed Average Noise Level Spurious Responses Third Order Intermodulation Second Harmonic Distortion Absolute Amplitude Accuracy Frequency Response (All Tests)
<b>A14</b> L.O. Synthesizer Assembly	FPGA Synchronization <sup>c</sup>	Residual Responses Displayed Average Noise Level Spurious Responses Phase Noise (All Tests) Frequency Response (All Tests)
<b>A15</b> Front End Control Assembly	FPGA Synchronization <sup>c</sup> YTF Alignment (Press <b>System, Alignments, Advanced, Characterize Preselector</b> ) Front End Controller Attenuator Adjustment (Option CR3 or CRP)	Residual Responses Displayed Average Noise Level Absolute Amplitude Accuracy Frequency Response (All Tests)

Table 15-1 Post-Repair Testing Requirements (Continued)

Assembly	Adjustments to Perform (in the order listed) <sup>a</sup>	Performance Verifications to Perform After Adjustments <sup>a</sup>
<b>A16</b> Reference Assembly	FPGA Synchronization <sup>c</sup> 10 MHz Frequency Reference Adjust 50 MHz Calibrator Amplitude Adjust 4800 MHz Calibrator Amplitude Adjustment (Option MPB)	Frequency Reference Accuracy Residual Responses Displayed Average Noise Level Frequency Readout Accuracy Count Accuracy Absolute Amplitude Accuracy Phase Noise (All Tests)
<b>A17</b> LED Board (Option BBA)	None	Residual Responses Displayed Average Noise Level
<b>A18</b> BNC Interface Board (Option BBA)	Press <b>Input/Output, I/Q, I/Q Cable Calibrate</b> Absolute Amplitude (Option BBA) Adjust	Residual Responses Displayed Average Noise Level Absolute Amplitude Accuracy at 250 kHz Frequency Response Below 250 kHz Frequency Response Above 250 kHz Channel Match
<b>A19</b> BBIQ Main Board (Option BBA)	FPGA Synchronization <sup>c</sup> Press <b>Input/Output, I/Q, I/Q Cable Calibrate</b> Absolute Amplitude (Option BBA) Adjust	Residual Responses Displayed Average Noise Level Absolute Amplitude Accuracy at 250 kHz Frequency Response Below 250 kHz Frequency Response Above 250 kHz Channel Match
<b>A25</b> Wide Band Analog IF (Option B85, B1A, B1X)	IF Frequency Response	Noise Density
<b>A26</b> Wide Band Digital IF (Option B85, B1A, B1X)	FPGA Synchronization <sup>c</sup>	
<b>SW1</b> Preselector Bypass Switch (Opt MPB)	Frequency Response (all tests) Attenuator Slope Hardware Statistical Reset	Frequency Response (all)
<b>SW2</b> Preselector Bypass Switch (Opt MPB)	Frequency Response (all tests) Attenuator Slope Hardware Statistical Reset	Frequency Response (all)

Table 15-1 Post-Repair Testing Requirements (Continued)

Assembly	Adjustments to Perform (in the order listed) <sup>a</sup>	Performance Verifications to Perform After Adjustments <sup>a</sup>
<b>W24</b> BBIQ Cable Assembly (Option BBA)	Press <b>Input/Output, I/Q, I/Q Cable Calibrate</b> Absolute Amplitude (Option BBA) Adjust	Residual Responses Displayed Average Noise Level Absolute Amplitude Accuracy at 250 kHz Frequency Response Below 250 kHz Frequency Response Above 250 kHz Channel Match

- a. Calibration Application Software is required for all performance tests and most adjustments. For details go to <http://www.keysight.com/find/calibrationsoftware>
- b. IF Frequency Response adjustment only performed if Option B25 and/or B40 are present and analyzer is equipped with Option MPB.
- c. See the Additional Tasks section in this chapter for detailed instructions on this task.
- d. To set the instrument time and date press **Start, Control Panel, Date Time Language and Regional Options, Date and Time**
- e. Before replacing the A5 Disk Drive, see the “Calibration Data Backup and Rest360re” section in this chapter for details.
- f. See Chapter 17, “Instrument Software” for instructions on updating the instrument software to the latest version.

**NOTE**

Some Adjustment tests may be found in the Utility portion of the Test Plan.

## Additional Tasks

### Calibration Data Backup and Restore

#### Data Backup

In order for the instrument being repaired to not need all of the instrument adjustments and performance verification tests to be run after the A5 Disk Drive is replaced the calibration data will need to be backed up onto an external drive prior to removing the existing disk drive.

#### NOTE

While the backing up and restoring of the calibration data to the new disk drive will return the instrument performance to the state that it was prior to a repair this does not guarantee that all instrument performance parameters meet their specified values. A full instrument calibration would be required to verify this.

---

There are two different types of calibration file databases that the instrument being repaired could be using, and three different backup procedures that might need to be followed. Which backup procedure to be run will depend on the software version that currently exists in the instrument being repaired.

To determine which calibration data backup procedure needs to be run determine the current instrument software version by pressing **System, Show, System** on the instrument and follow the steps outlined below for that version.

#### S/W Revision Less Than A.01.55

1. Close the instrument application software by pressing **File, Exit, Enter** using the front panel keys.
2. Connect a USB mouse to one of the instrument front panel USB ports.
3. Connect a USB FLASH drive to the other front panel USB port.
4. Using the mouse double-click on the Windows Explorer link on the desktop and navigate to the following folder:

E:\AlignDataStorage

5. Copy the following file onto the USB FLASH drive:

CurrentDataSet.xml

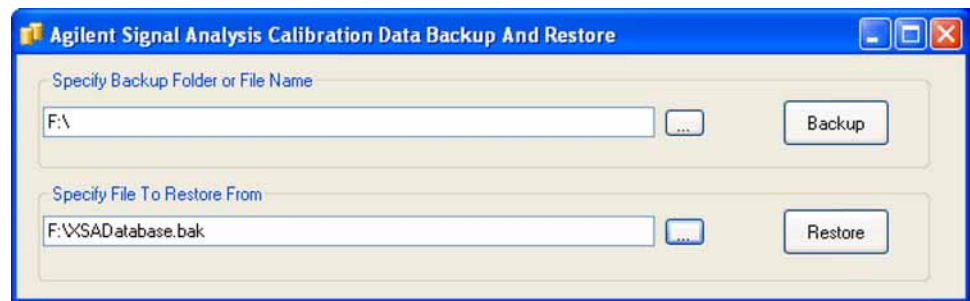
S/W Revision Greater Than or Equal To A.01.55 and Less Than A.02.00

1. Close the instrument application software by pressing **File, Exit, Enter** using the front panel keys.
2. Connect a USB mouse to one of the instrument front panel USB ports.
3. Connect a USB FLASH drive to the other front panel USB port.
4. Using the mouse double-click on the Windows Explorer link on the desktop and navigate to the following folder:

C:\Program Files\Agilent\SignalAnalysis\Physics

5. Double-click on BackupAndRestore.exe and the window shown in **Figure 15-1** will appear.

**Figure 15-1** Calibration Data Backup



6. Under the “Specify Backup Folder or File Name” use the mouse to select the “...” button to open the “Browse For Folder” dialog box.
7. Select the USB FLASH drive and press **OK**.

**NOTE**

While you can use the “Make New Folder” button in the “Browse For Folder” dialog box to create a sub-folder on the USB FLASH drive, and you can specify a filename in the “Specify Backup Folder or File Name” window, you can also just use the root directory on the drive and let the instrument select a default filename for you.

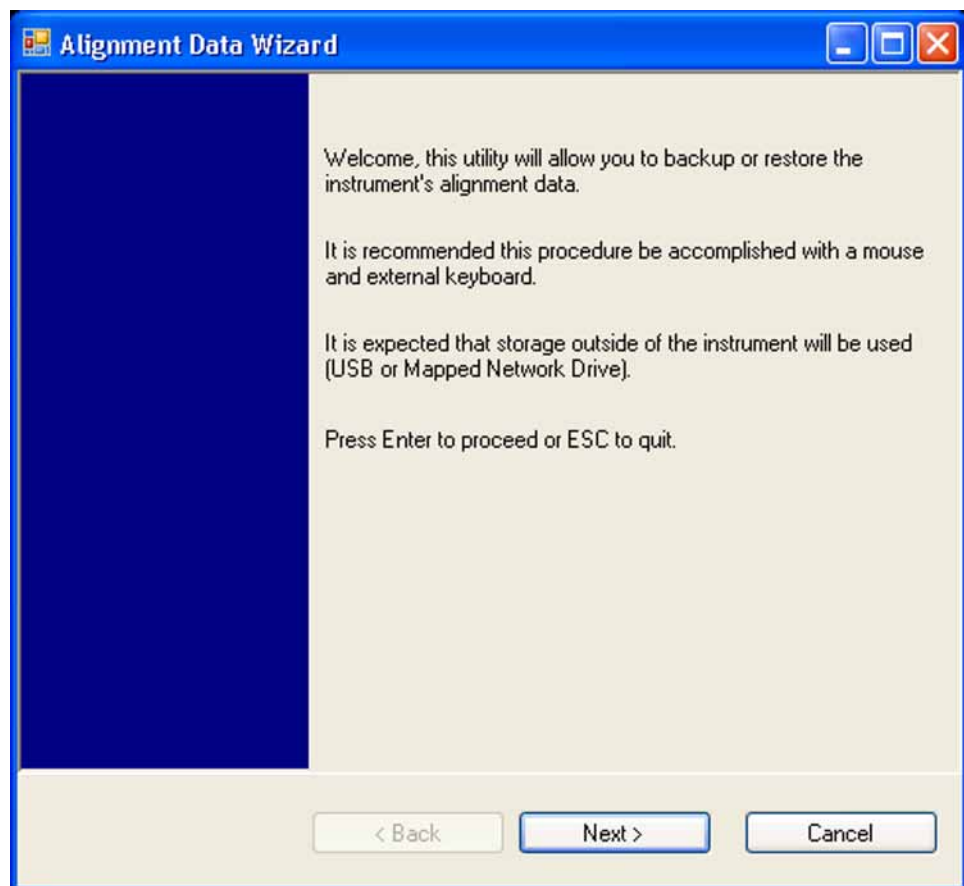
8. Select “Backup” and wait for the calibration database to be backed up.
9. When the backup has completed close the Calibration Data Backup And Restore window.



### S/W Revision Greater Than or Equal To A.02.00

1. Connect a USB keyboard and mouse to two of the instrument rear panel USB ports
2. Connect a USB FLASH drive to one of the front panel USB ports.
3. Press **System, Alignments, Backup or Restore Align Data**.
4. The Alignment Data Wizard window as shown in **Figure 15-2** will appear.

**Figure 15-2** Alignment Data Wizard



5. Follow the on-screen instruction to backup the calibration data to the USB FLASH drive.

## Data Restore (.xml File)

If the instrument being repaired was using a software version prior to A.01.55 it would have been using an .xml database file for its calibration data, and this data will need to be restored using the following process.

1. Close the instrument application software by pressing **File, Exit, Enter** using the front panel keys.
2. Connect a USB mouse to one of the instrument front panel USB ports.
3. Locate the USB FLASH drive that was earlier used to backup the instrument calibration file and insert it into one of the instrument front panel USB ports.
4. Using the mouse double-click on the Windows Explorer link on the desktop and navigate to the folder on the USB FLASH drive where you previously saved the calibration data file.
5. Locate the following file, which was previously saved to the USB FLASH drive:

CurrentDataSet.xml

6. Highlight the calibration data file and copy the file to the instrument clipboard by selecting **Edit, Copy** from the Windows Explorer pull-down menu.
7. Navigate to the folder below and paste the file by selecting **Edit, Paste** from the Windows Explorer pull-down menu:

E:\AlignDataStorage

8. Verify that the CurrentDataSet.xml file was copied to the new disk drive
9. Cycle the instrument power.

When the instrument application software starts up it will see this older format data file and convert it to the new SQL database. Any further backing up of the data will now be done through the instrument Alignment Data Wizard application which can be found in the instrument application software under **System, Alignments, Backup or Restore Align Data...**

## Data Restore (SQL Database)

If the instrument being repaired was using instrument software version A.01.55 or newer prior to this repair it was already using an SQL database file for its calibration data, so it can be easily restored with the instrument Alignment Data Wizard using the following procedure.

1. Connect a USB mouse to one of the instrument front panel USB ports.
2. Locate the USB FLASH drive that was earlier used to backup the instrument calibration file and insert it into one of the instrument front panel USB ports.
3. Restore the instrument calibration data by pressing: **System, Alignments, Backup or Restore Align Data...** The Alignment Data Wizard window as shown in **Figure 15-2** will appear.
4. Follow the on-screen instruction to restore the previously saved calibration data from the USB FLASH drive.
5. Cycle the power.

## BIOS Settings Verification

Whenever either the A4 CPU assembly or the A4BT1 CPU Battery is changed there are certain BIOS settings that need to be verified. If these are not set correctly the instrument may not boot up or operate correctly.

The BIOS settings that need to be verified, as well as the BIOS configuration screens used, will vary depending on the A4 CPU assembly.

### Selection of BIOS Settings Procedure

**The MXA has had three standard CPUs:**

- Single-Core Processor (standard on MXAs with serial numbers prior to MY/SG/US49100000; identifies as Option N9020A-PC1 with instrument software A.02.00 or later)
- Dual-Core Processor (standard on MXAs with serial numbers  $\geq$  MY/SG/US49100000 to  $<$  MY/SG/US52090000; identifies as N9020A-PC2; available as an upgrade for older MXAs)
- High-Performance Dual-Core Processor (standard on MXAs with serial numbers  $\geq$  MY/SG/US52090000; identifies as N9012A-PC4; available as an upgrade for older MXAs.)

**Each of these CPUs uses a unique BIOS.**

The steps below will help you identify which BIOS settings procedure to perform.

- 1. Connect an external USB keyboard to one of the front panel USB ports.**
- 2. Turn on the analyzer power.**
- 3. Confirm Agilent Technologies splash screen comes up within a few seconds. “Agilent Technologies” will appear in white letters on a black background.**
- 4. Press “F2” and then “Delete” on the external keyboard when at the Agilent Technologies splash screen to enter the CPU BIOS Setup Utility. The older CPUs (N9020A-PC1 and N9020A-PC2) respond to “F2” while the newer CPU (N9020A-PC4) responds to the “Delete” key.**
- 5. If the CPU BIOS Setup Utility main screen appears as in [Figure 15-3](#), follow the procedure for the Single-Core Processor.**
- 6. If the CPU BIOS Setup Utility main screen appears as in [Figure 15-4](#), follow the procedure for the Older Dual-Core Processor**
- 7. If the CPU BIOS Setup Utility main screen appears as in [Figure 15-5](#), follow the procedure for the newer Dual-Core processor**
- 8. If the CPU BIOS Setup Utility main screen appears as in [Figure 15-6](#), follow the procedure for the High-Performance Dual-Core Processor.**

Figure 15-3 Single-Core Processor BIOS Setup Utility Main Screen

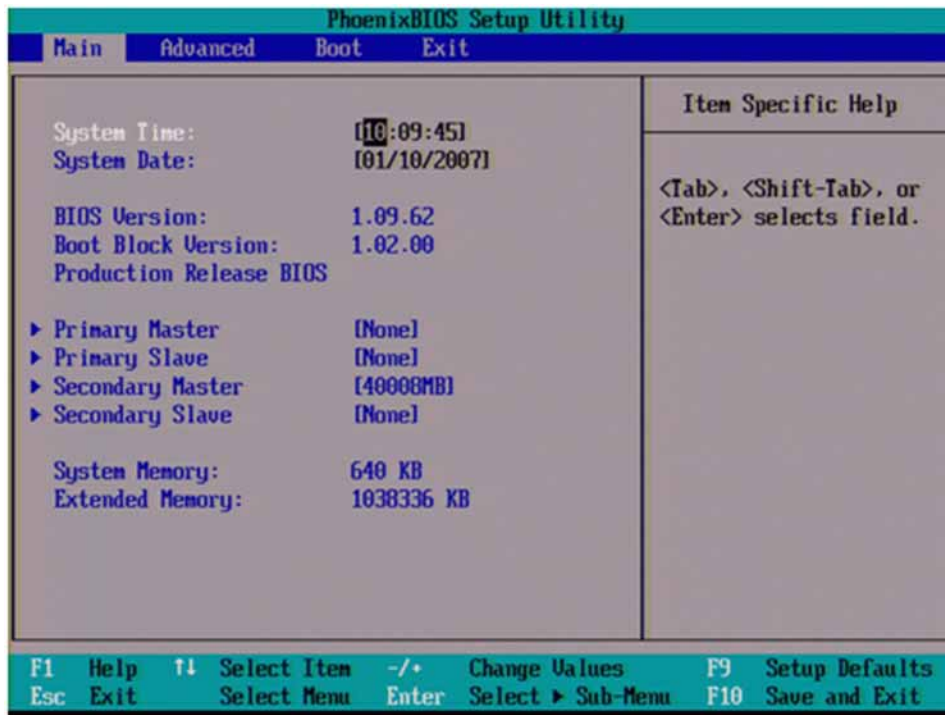


Figure 15-4 Older Dual-Core Processor BIOS Setup Utility Main Screen

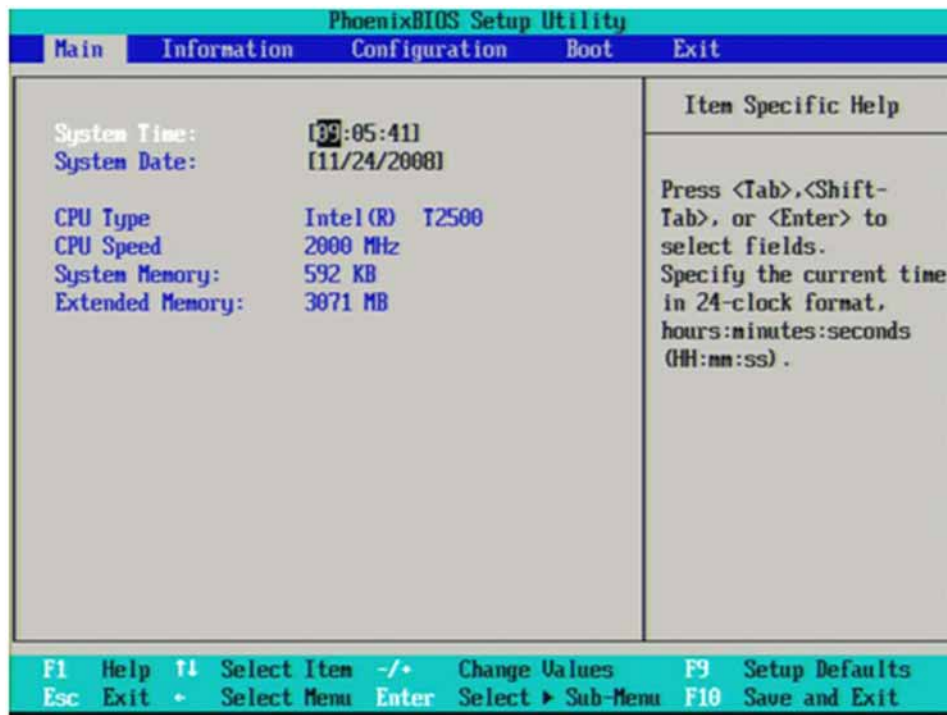
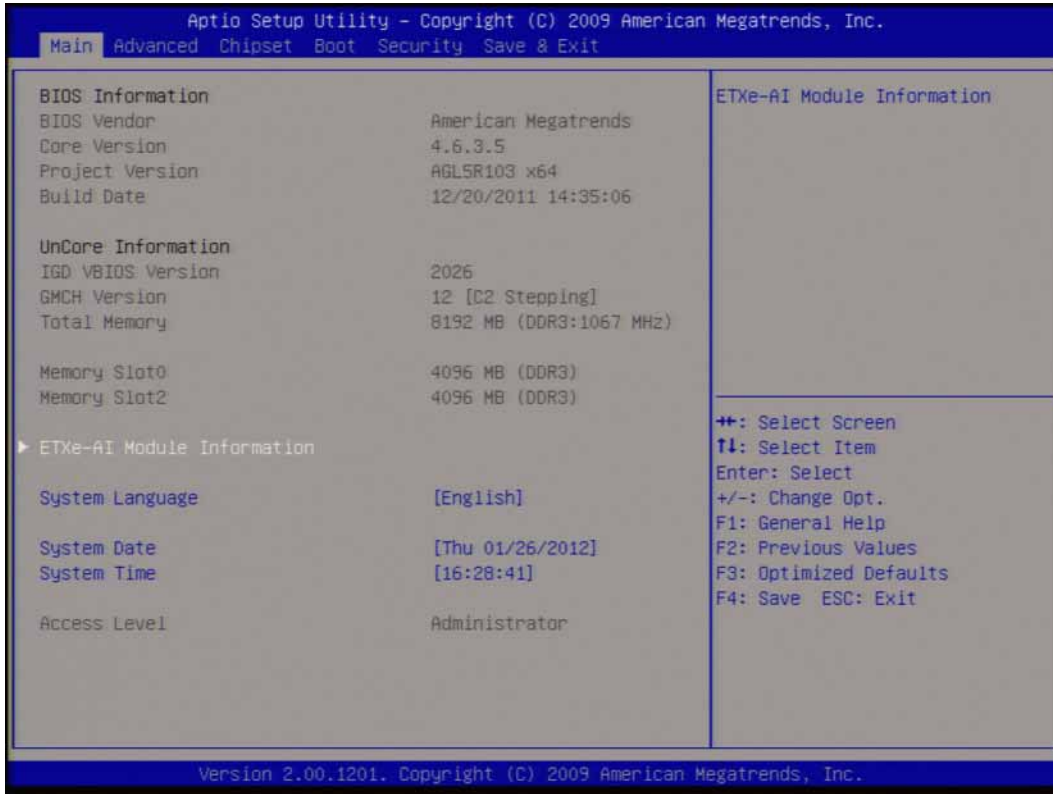


Figure 15-5

Newer Dual-Core Processor BIOS Setup Utility Main Screen



Figure 15-6 High Performance Dual-Core Processor BIOS Setup Utility Main Screen



## Single-Core Processor

There are two settings in the CPU BIOS that must be verified and may require changing when the A4 CPU assembly or A4BT1 CPU battery is replaced. These settings need to be correct in order for the analyzer to boot up and operate correctly.

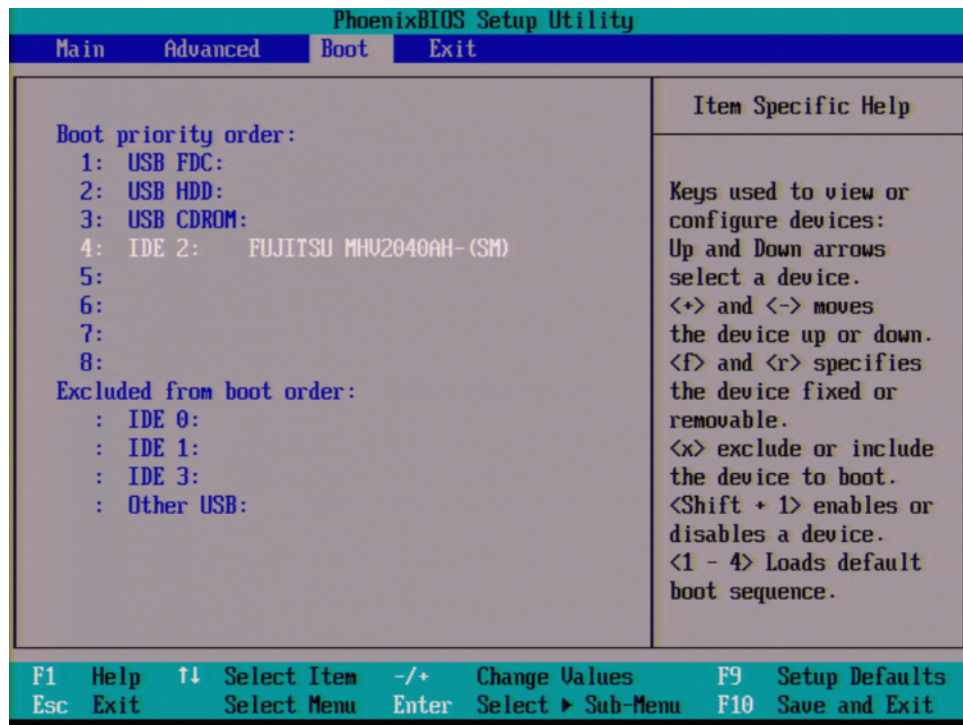
- “IDE 2” must be set to #1 in the “Boot priority order”
- “CK-408 Spread Spectrum” must be set to “Enabled”

Changing and saving these BIOS settings requires a USB external keyboard. Changes to the BIOS are fairly straightforward and should take ~30 seconds.

### Verifying Boot Priority

1. Press the Right Arrow on the external keyboard twice to highlight the Boot tab as shown in [Figure 15-7](#).

**Figure 15-7** Boot Tab Highlighted

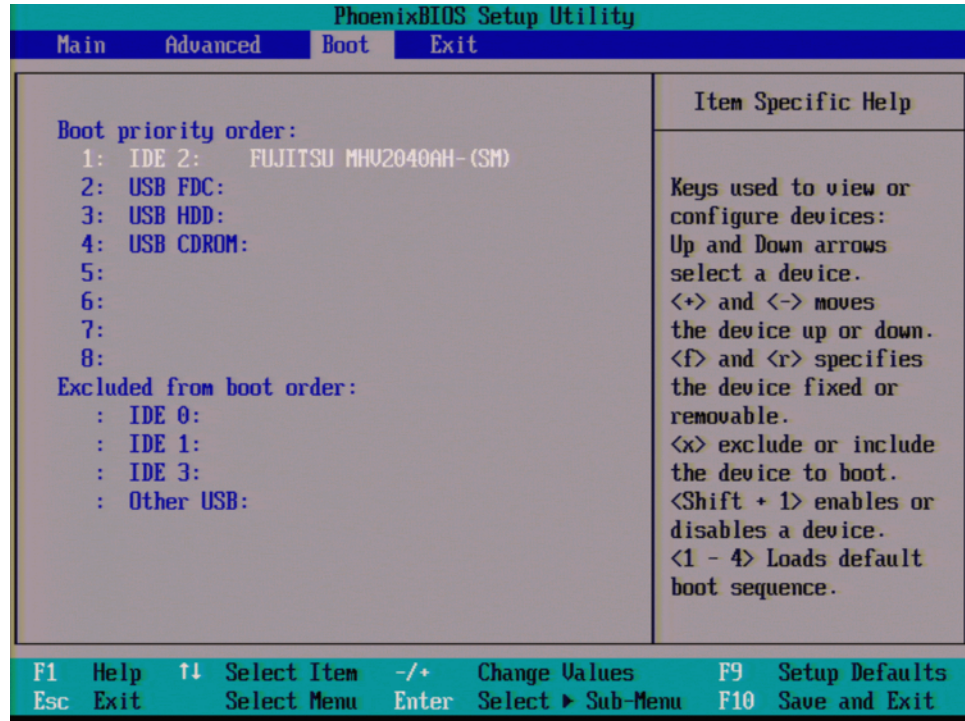


2. If IDE 2 is not listed 1st in the boot priority, press the Down Arrow on the external keyboard to highlight IDE 2 as shown in [Figure 15-7](#).



3. Press the “+” key on the external keyboard to bring IDE 2 to the top of the list as shown in [Figure 15-8](#).

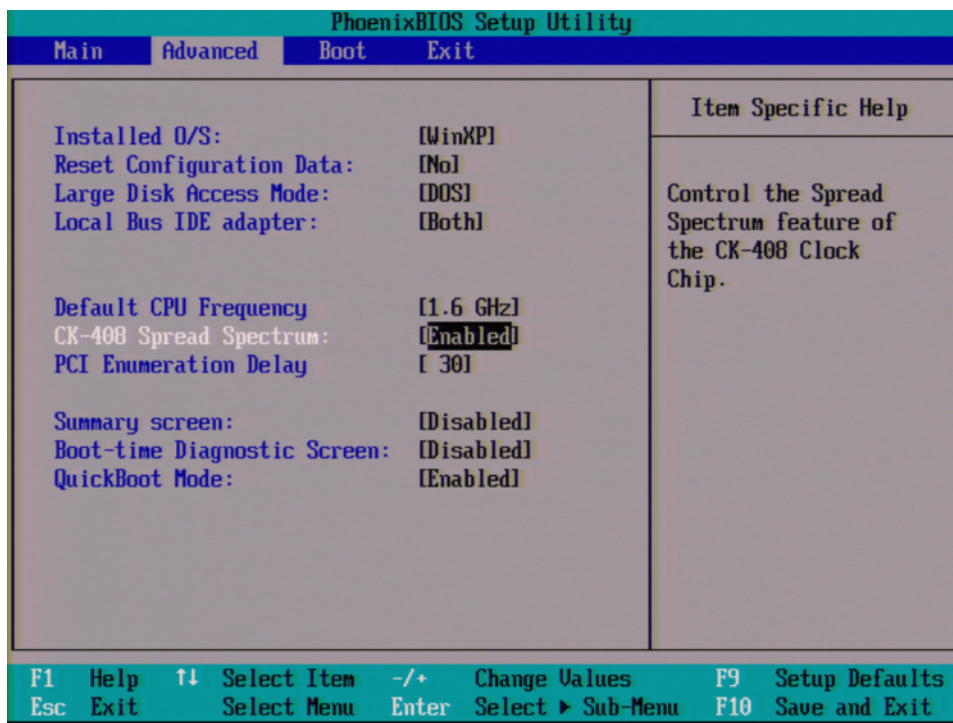
**Figure 15-8** IDE 2 at Top of List



## Enabling Spread Spectrum

1. Press the Left Arrow on the external keyboard to highlight the Advanced tab as shown in [Figure 15-9](#).

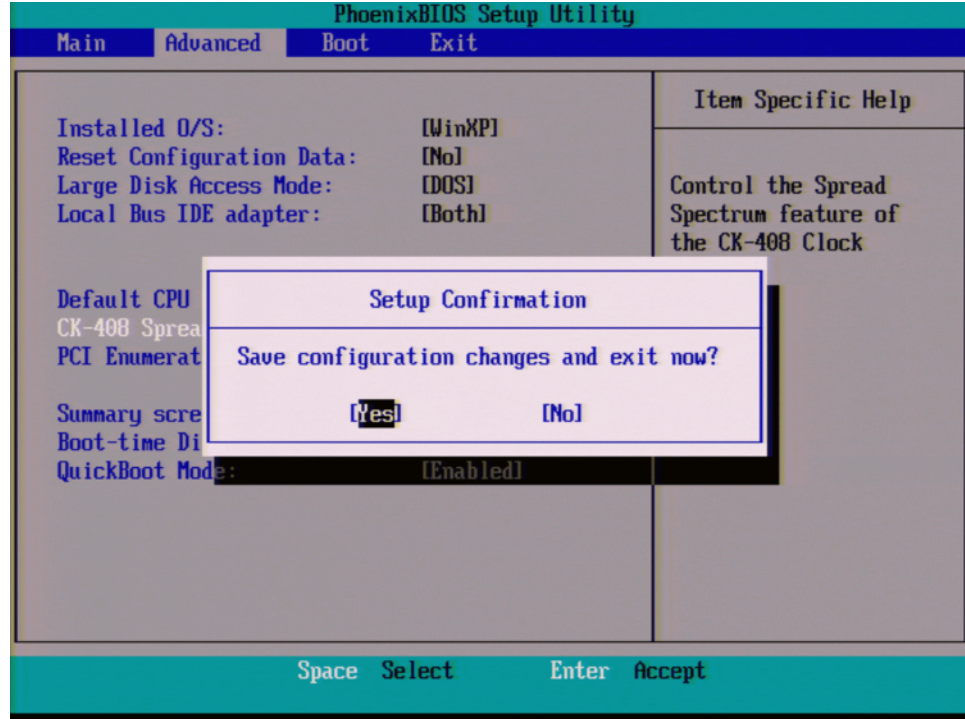
**Figure 15-9** Advanced Tab Highlighted



2. Press the Down Arrow on the external keyboard to highlight CK-408 Spread Spectrum
3. Use the “+” key on the external keyboard to change the setting from [Disabled] to [Enabled]
4. Press “F10” on the keyboard to save changes and exit.

5. Press the Enter key on the external keyboard to confirm the BIOS configuration changes as per [Figure 15-10](#).

**Figure 15-10** Confirm BIOS Configuration



6. Perform the remaining adjustments and performance tests as per [Table 15-1](#) for the assembly that was changed.

## Older Dual-Core Processor

There is one setting in the CPU BIOS that must be verified and may require changing when the A4 CPU assembly or A4BT1 CPU battery is replaced. This setting needs to be correct in order for the analyzer to always boot up correctly.

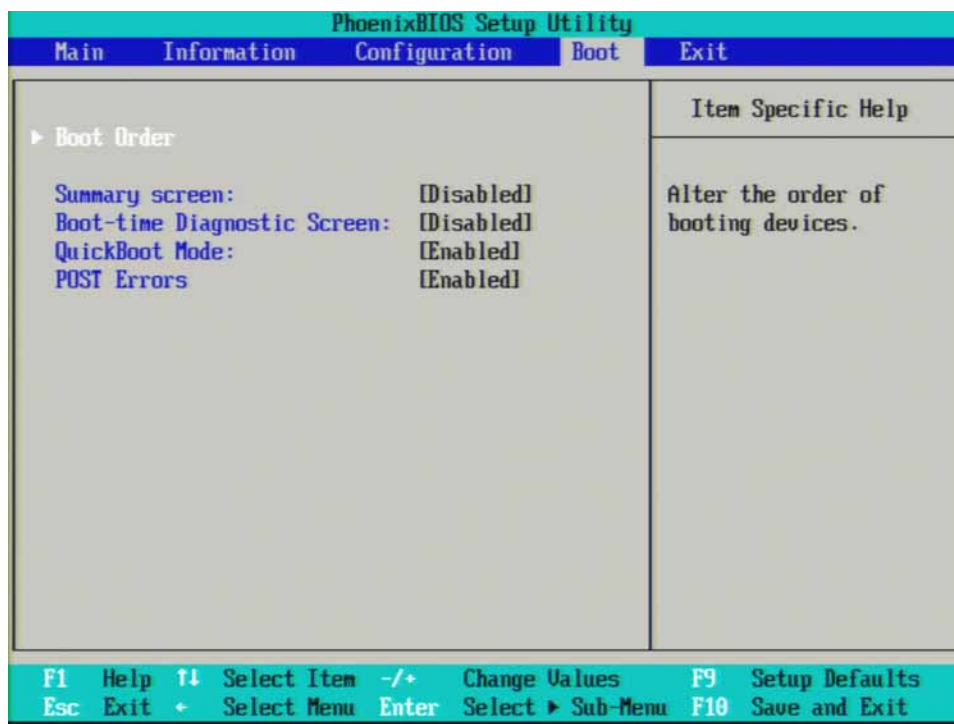
- “IDE HDD” must be set to #1 in the “Boot priority order”

Changing and saving these BIOS settings requires a USB external keyboard. Changes to the BIOS are fairly straightforward and should take ~30 seconds.

### Verifying Boot Priority

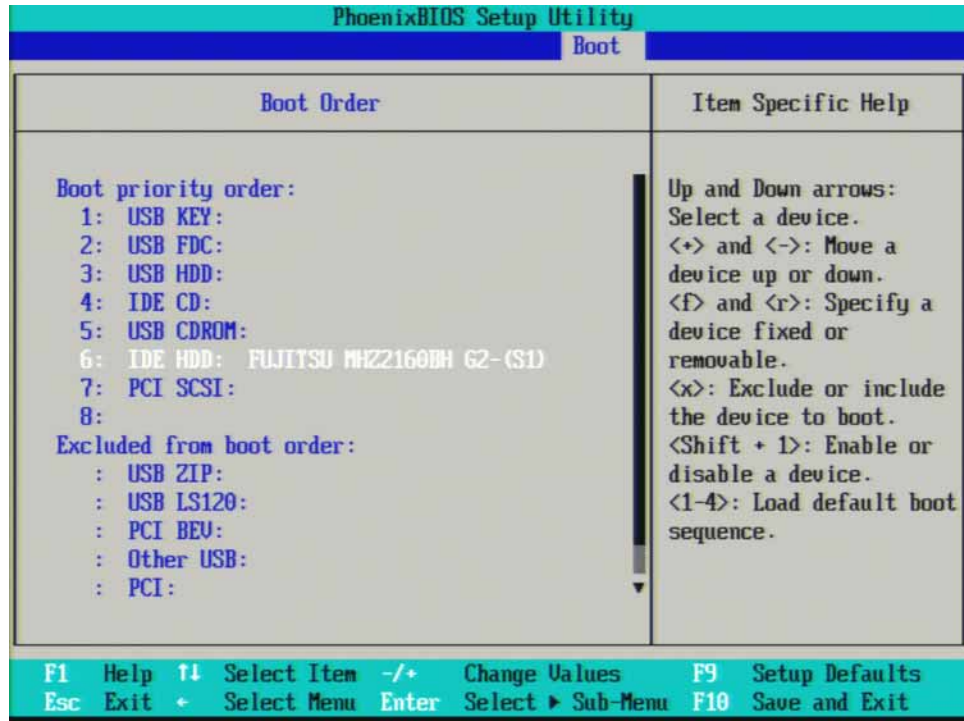
1. Press the Right Arrow on the external keyboard three times to highlight the Boot tab as shown in [Figure 15-11](#).

**Figure 15-11** Boot Tab Highlighted



2. With Boot Order highlighted as shown in [Figure 15-11](#) press Enter on the external keyboard to enter the Boot Order Configuration screen.

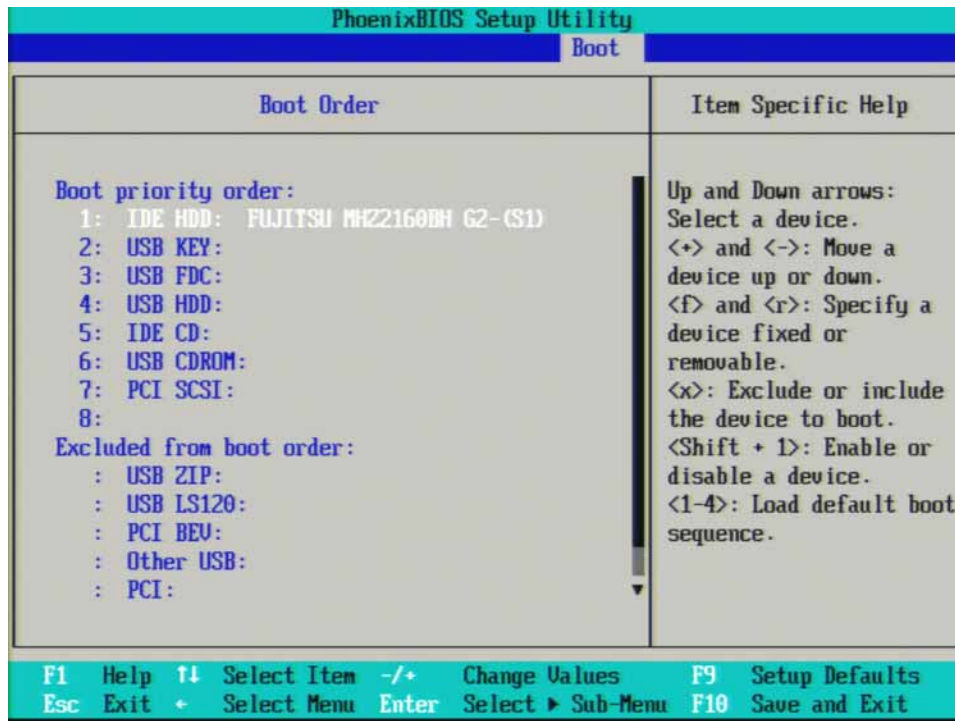
Figure 15-12 IDE HDD Selected



3. If IDE HDD is not listed first in the boot priority, press the Down Arrow on the external keyboard to highlight IDE HDD as shown in [Figure 15-12](#).

4. Press the “+” key on the external keyboard to bring IDE HDD to the top of the list as shown in [Figure 15-13](#).

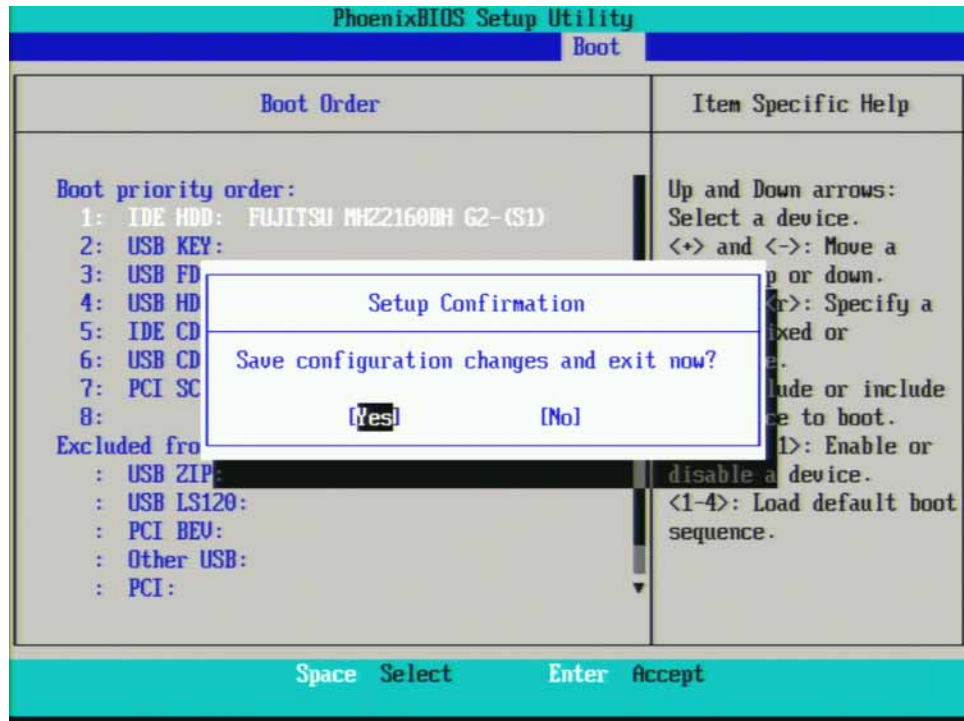
**Figure 15-13** IDE HDD at Top of List



## Save Changes

1. Press “F10” on the keyboard to save changes.
2. Press the Enter key on the external keyboard to confirm the BIOS configuration changes as per [Figure 15-14](#).

**Figure 15-14** Confirm BIOS Configuration



## Newer Dual-Core Processor

There is one setting in the CPU BIOS that must be verified and may require changing when the A4 CPU assembly or A4BT1 CPU battery is replaced. This setting needs to be correct in order for the analyzer to always boot up correctly.

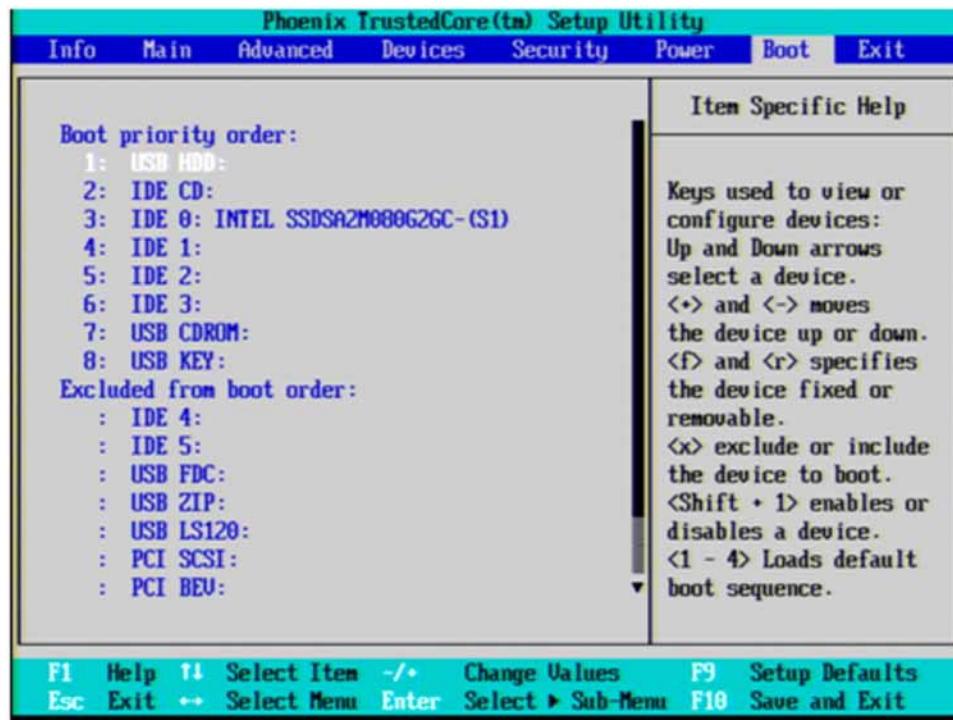
- “IDE HDD” must be set to #1 in the “Boot priority order”

Changing and saving these BIOS settings requires a USB external keyboard. Changes to the BIOS are fairly straightforward and should take ~30 seconds.

### Verifying Boot Priority

1. Press the Right Arrow on the external keyboard five times to highlight the Boot tab as shown in [Figure 15-15](#).

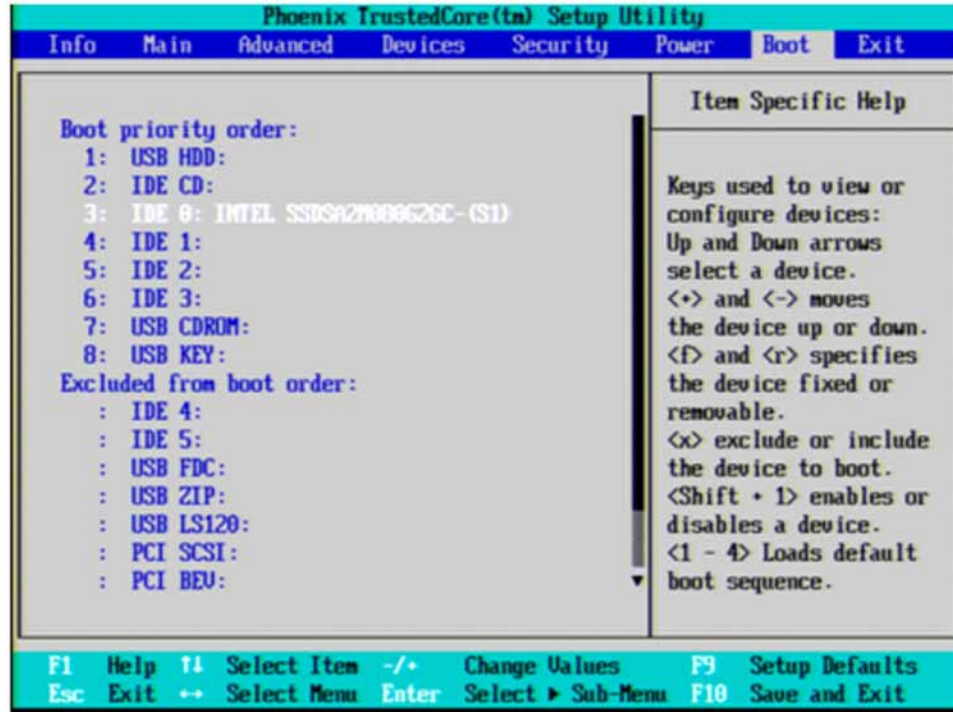
**Figure 15-15** Boot Tab Highlighted





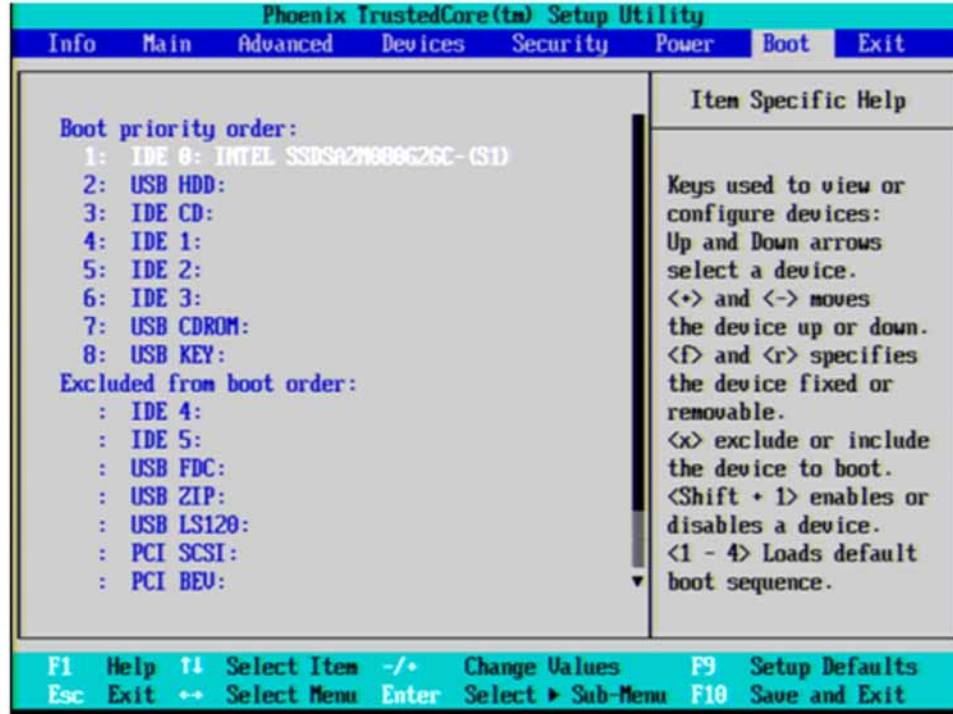
2. If "IDE 0" is not listed first in the boot priority, press the Down Arrow on the external keyboard to highlight "IDE 0" as shown in [Figure 15-16](#).

**Figure 15-16** IDE 0 Selected



3. Press the “+” key on the external keyboard to bring IDE 0 to the top of the list as shown in [Figure 15-17](#).

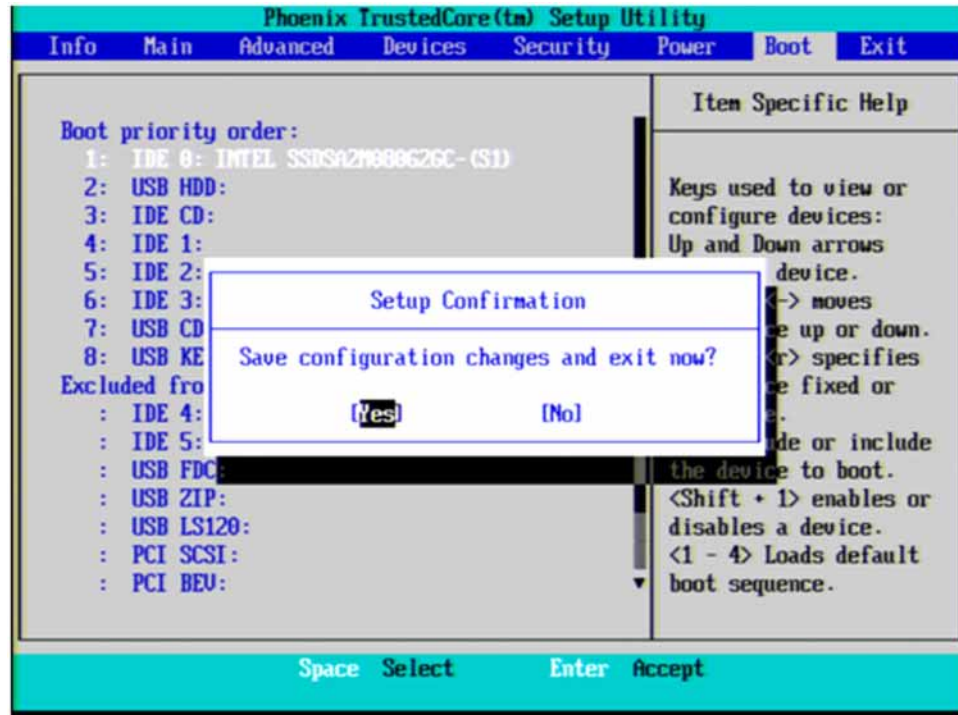
**Figure 15-17** IDE 0 at the Top of List



## Save Changes

1. Press “F10” on the keyboard to save changes.
2. Press the Enter key on the external keyboard to confirm the BIOS configuration changes as per [Figure 15-18](#).

**Figure 15-18** Confirm BIOS Configuration

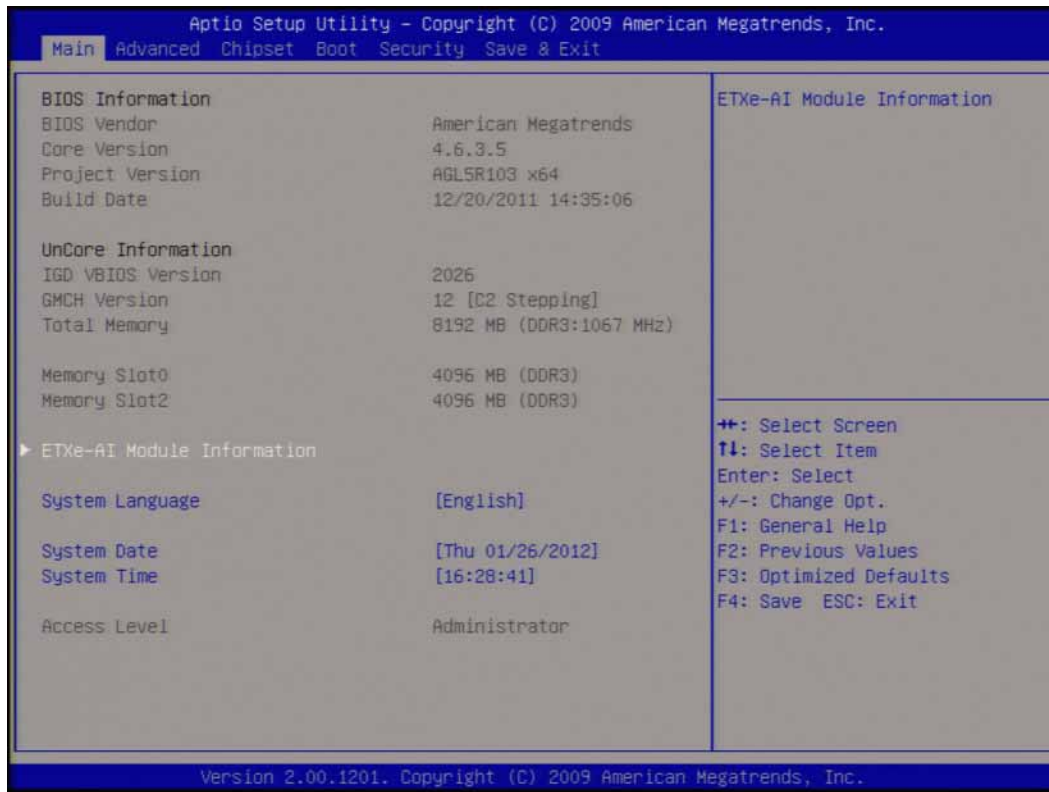


## High-Performance Dual-Core Processor

### Save Changes

1. Press “F3” on the external keyboard to select Optimized Defaults. A dialog box will appear asking you to confirm your selection. Select “Yes” and press the Enter key on the external keyboard.

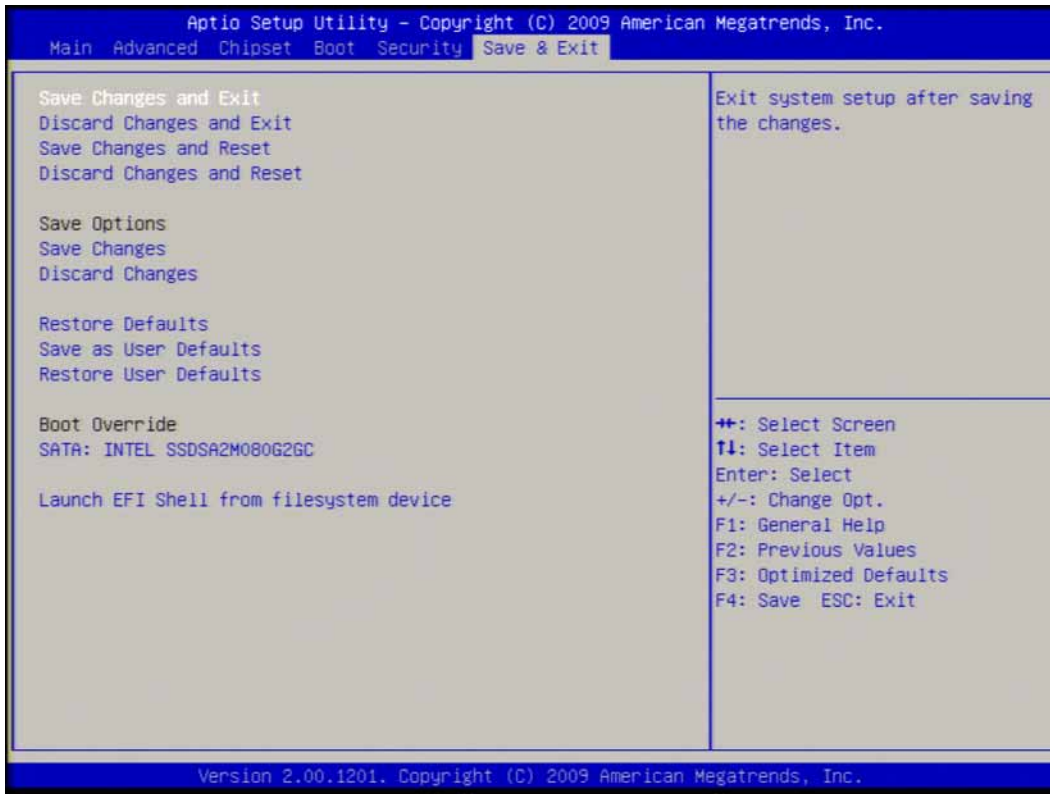
**Figure 15-19** Selecting Optimized Defaults



### Save Changes

1. Press the right arrow on the external keyboard to select the “Save and Exit” tab.
2. Press the down arrow key to select “Save Changes and Exit” as shown in **Save Changes**. Press the Enter key.
3. Press the Enter key again to confirm.

Figure 15-20 Save Changes



## End User License Agreement (EULA) Acceptance (Software versions $\leq$ A.06.08)

**NOTE** The Microsoft End-User License agreement will be displayed whenever the A5 Disk Drive has been replaced, and this must be accepted.

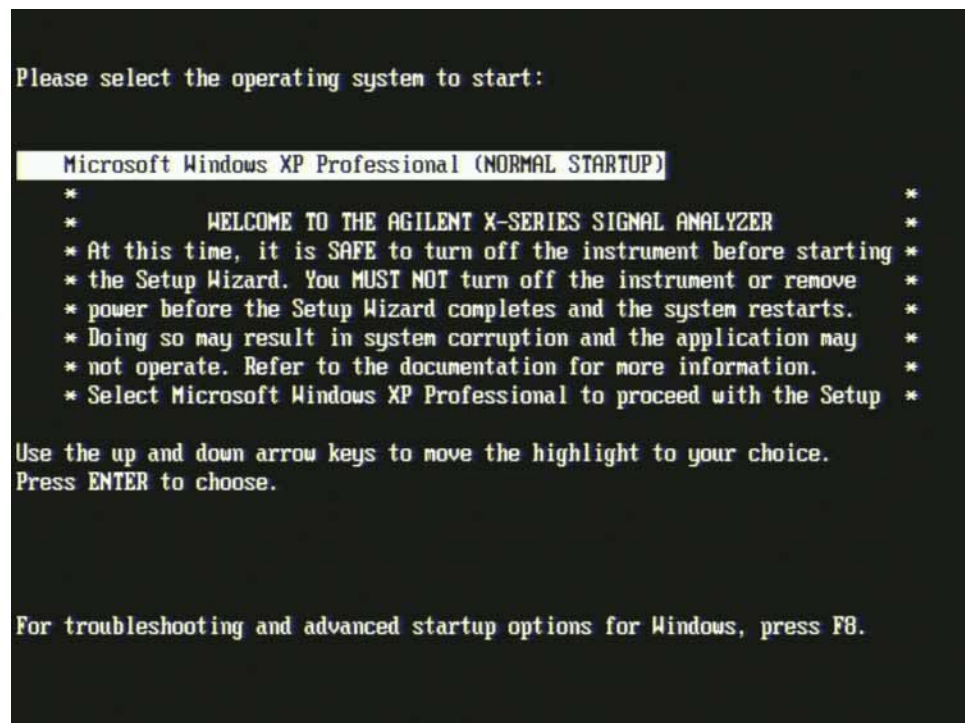
---

The License Agreement screen asks you to accept the terms of the End-User License Agreement for Windows XP. You must accept this agreement to continue the Windows XP installation and configuration. If you do not accept this agreement, the instrument shuts down and the next time you turn it on the Windows XP Setup Wizard starts from the beginning again.

### Accepting the End-User License Agreement (EULA) Screen

The instrument will display the Agilent Welcome Screen shown in [Figure 15-21](#) and wait for **Enter** to be pressed to continue.

Figure 15-21 Agilent Welcome Screen (Software versions  $\leq$  A.06.08)



1. Press **Enter** to proceed with the Windows XP setup.
2. When you see the Windows XP Setup Wizard screen as seen in **Figure 15-22**, press **Enter** to move to the License Agreement screen.

**Figure 15-22** Windows XP Setup Wizard



3. When the Windows XP License Agreement window comes up, select "I accept this agreement" and press **Next**.
4. The Date and Time Settings screen is used to set the appropriate date, time and time zone. These settings will be configured later by the end user.  
Select **Next** to continue the Windows XP Setup Wizard.
5. Wait for the Windows XP Setup Wizard to complete. The instrument will restart itself a few times.
6. Once the Windows XP Setup Wizard has completed the instrument is ready for the next step of configuration.

### End User License Agreement (EULA) Acceptance (Software versions $\geq$ A.07.00)

Beginning with instrument software version A.07.00 and later, it is no longer necessary to actively accept the end-user license agreement (EULA) when replacing the A5 Disk Drive. However, a Welcome screen, as in [Figure 15-23](#) below, will give you information about the EULA.

#### Accepting the End-User License Agreement (EULA) Screen

The instrument will display the Agilent Welcome Screen shown in [Figure 15-23](#) and wait for **Enter** to be pressed to continue.

Figure 15-23

#### Agilent Welcome Screen (Software versions $\geq$ A.07.00)





1. Press **Enter** to proceed with the Windows XP setup. See **Figure 15-24**.

**Figure 15-24** Windows XP Setup Wizard



2. The Date and Time Settings screen is used to set the appropriate date, time and time zone. These settings may be configured later by the end user.  
Select **Next** to continue the Windows XP Setup Wizard.
3. Wait for the Windows XP Setup Wizard to complete. The instrument will restart itself a few times.
4. Once the Windows XP Setup Wizard has completed the instrument is ready for the next step of configuration.

## FPGA Synchronization

There is FPGA (Field-Programmable Gate Array) program code on many different assemblies inside of the instrument, and all of these must be of a compatible version with the instrument software revision. In order to ensure that this requirement is met when either an assembly is replaced that contains FPGA code on it, or if the A5 Disk Drive is replaced with a drive that has a different version of software than the previous drive, you will need to take certain steps to ensure that the instrument operates properly.

### NOTE

Even if an instrument appears to work properly when an assembly with FPGA code is replaced, that does not mean that the FPGA code is completely compatible with the software version installed in the instrument. There could be incompatibilities that will only be seen under certain measurement conditions.

---

Depending on the revision of the instrument software there are two possible ways to synchronize the FPGA codes with the instrument software revision. To determine which synchronization process will need to be run perform the following:

1. Check the current instrument software revision. To determine the software revision press **System, Show, System** on the instrument.
2. If the instrument software revision is prior to A.02.00 the instrument software will need to be updated. See Chapter 17, "Instrument Software" for instructions.

When the instrument software update is run all of the instrument FPGA code will be updated to the revision required for the installed software.

Once the software update has been installed the FPGA code synchronization procedure will be completed.

3. If the instrument software revision is A.02.00 or newer the FPGA code for all of the different assemblies can be updated following the procedure below titled "Updating the Instrument FPGA Code".

## Updating the Instrument FPGA Code

Instruments that have software revision A.02.00 or newer have a utility included in them that will update the FPGA code on all of the different assemblies in the instrument that have it. When this utility is run it will detect the assemblies that need to be updated and will update them to the correct revision.

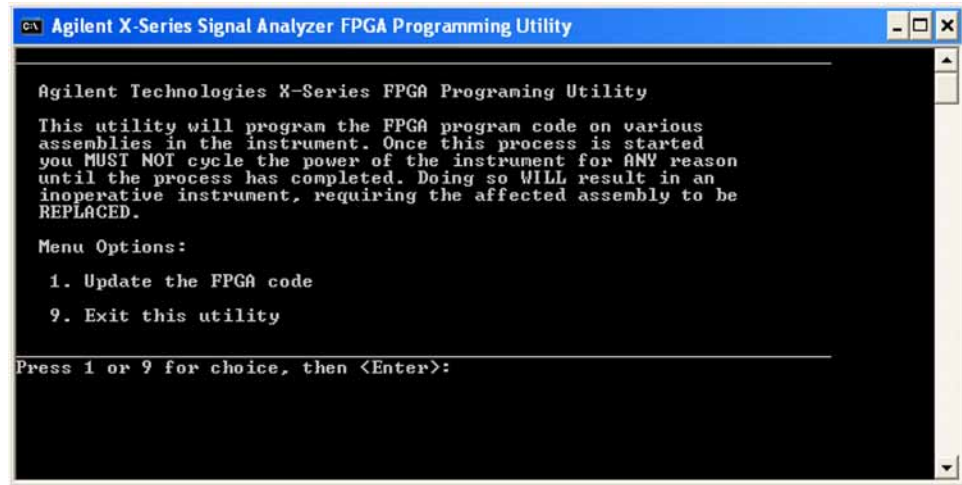
### NOTE

Once you start the FPGA programming process you **MUST NOT** interrupt the process for any reason. This would include turning the instrument off or unplugging the power cord to the instrument. Doing so will result in an inoperative instrument, requiring the affected assembly to be replaced.

---

1. Close the instrument application software by pressing **File, Exit, Enter** using the front panel keys.
2. Connect a USB mouse and keyboard to one of the instrument front panel USB ports.
3. Using the mouse, click **Start, Log Off, Log Off**.
4. Re-login as “administrator”. The default password is “agilent4u”. Click **OK**.
5. Using the mouse double-click on the Windows Explorer link on the desktop and navigate to the following folder:  
  
C:\Program Files\Agilent\SignalAnalysis\Physics
6. In this folder find and execute the file named:  
  
FPGA\_Prog.bat
7. The FPGA Programming Utility will start and a window as shown in **Figure 15-25** will appear.

Figure 15-25 FPGA Programming Utility



- 8.** To program the FPGA code enter **1** and press **Enter**. You will need to confirm this selection by pressing **1** and **Enter** one more time.
- 9.** The programming of the FPGA code could take a few minutes to complete. Once it has finished the instrument will reboot itself to use the new code and this process will then be completed.

## Programming Model and Serial Numbers

Since the instrument model and serial numbers are stored only on the A7 Midplane board assembly, this information will be lost when this board assembly is replaced. Until the instrument model and serial numbers are restored the instrument application software will not allow any user measurements to be made, due to the fact that all previously installed license keys will not be accepted. However, the license files will not be automatically deleted. Once the model and serial numbers are restored the license files will then be recognized and accepted, returning the instrument to the capability that was available prior to the A7 Midplane board assembly replacement.

To program the model and serial numbers into a replacement A7 Midplane board assembly the N7814A Keysight X-Series Signal Analyzer Calibration Application Software will be required.

Information regarding N7814A Keysight X-Series Signal Analyzer Calibration Application Software can be found at:

<http://www.keysight.com/find/calibrationsoftware>

When the calibration software first detects the instrument it will recognize that it does not have a valid model and serial number and will prompt the user to enter the correct values.

### NOTE

**Be very careful when entering the instrument serial number into the software, because once it has been written it can no longer be changed.**

---

Since the instrument model and serial numbers are stored on the A7 Midplane board assembly, this should only be required when this assembly has been replaced with a new one.

## 16 Functional Tests

### Functional Test Versus Performance Verification

Functional tests are tests of various instrument parameters that give a high degree of confidence that the analyzer is operating correctly. They are recommended as a check of analyzer operation for incoming inspection or after a repair. Measurement uncertainty analysis is not available for functional tests, and the analyzer is checked against limits that are wider than the published specifications. The functional tests are designed to test an analyzer operating within the temperature range defined by the analyzer specifications using a minimum set of test equipment. If a test does not pass, performance verification tests must be run to determine whether a problem exists.

Functional tests use a minimum set of test equipment to check a much smaller range of parameters (and a limited number of data points for each parameter) than do performance verification tests. Functional tests use limits that are wider than the published specifications; measurement uncertainty analysis is **not** available for functional tests.

#### NOTE

If a functional test does not pass, you must run performance verification tests to determine whether a problem exists.

---

Performance verification tests span a wide range of instrument parameters and provide the highest level of confidence that the instrument conforms to published specifications. These tests can be time consuming and require extensive test equipment.

## Before Performing a Functional Test

1. Ensure that you have the proper test equipment.
2. Switch on the unit under test (UUT) and let it warm up (in accordance with warm-up requirements in the instrument specifications).
3. Allow sufficient warm-up time for the required test equipment (refer to individual instrument documentation for warm-up specifications).
4. Ensure that the analyzer's frequency reference is set to Internal:
  - a. Press the **Input/Output**, **More**, **Freq Ref In** keys.
  - b. If the **Freq Ref In** softkey does **not** show Internal, press the **Freq Ref In** softkey and select Internal.
5. Following instrument warm-up, perform the auto align routine:  
Press **System**, **Alignments**, **Align Now**, **All**.

### NOTE

Functional test accuracy depends on the precision of the test equipment used. Ensure that all of the test equipment is calibrated before running a functional test.

---



## Test Equipment

The table below summarizes the test equipment needed to perform all of the functional tests. Alternate equipment model numbers are given in case the recommended equipment is not available. If neither the recommended nor the alternative test equipment are available, substitute equipment that meets or exceeds the critical specifications listed.

Table 16-1

Analyzer Option	Item	Critical Specifications	Recommended Keysight Model	Alternate Keysight Model
<b>Adapters</b>				
All	3.5 mm (f) to 3.5 mm (f) (connector saver for source)	Frequency: 10 MHz to 26.5 GHz VSWR: < 1.1:1	83059B	1250-1749
All	BNC (f) to SMA (m)	Frequency: 40 MHz	1250-1200	
All	Type N (f) to Type N (f)	Frequency: 10 MHz to 18 GHz VSWR: < 1.05:1	1250-1472	1250-0777
All	Type N (m) to 3.5 mm (m)	Frequency: 10 MHz to 18 GHz VSWR: < 1.1:1	1250-1743	
All	Type N (m) to 3.5 mm (f)	Frequency: 10 MHz to 18 GHz VSWR: < 1.1:1	1250-1744	
All	Type N (f) to 3.5 mm (f)	Frequency: 10 MHz to 18 GHz VSWR: < 1.1:1	1250-1745	
All	Type N (m) to BNC (f)	Frequency: 10 MHz to 1 GHz VSWR: < 1.05:1	1250-1476	
<b>Attenuators</b>				
All	10 dB Step Attenuator	Frequency: 50 MHz <b>Range:</b> 0 to 70 dB	8495A	8496A
All	10 dB Fixed Attenuator (2 required)	Frequency: 50 MHz VSWR: < 1.2:1	8493C Option 010	8493A Option 010 or 8493B Option 010
Preamp Options (Pxx)	30 dB Fixed Attenuator	<b>Accuracy:</b> < 0.05 dB @ 50 MHz	11708A	

Functional Tests  
Test Equipment

Table 16-1

Analyzer Option	Item	Critical Specifications	Recommended Keysight Model	Alternate Keysight Model
<b>Cables</b>				
All	3.5 mm (1 meter)	Frequency: 10 MHz to 26.5 GHz VSWR: < 1.4:1 Loss: < 2.0 dB	11500E	8120-4921
All	Cable, BNC (3 required)	120 cm (48 in.) BNC cable	10503A	
BBA	Cable, BNC	120 cm (48 in.) BNC cable Flatness (250 kHz to 40 MHz) < 0.5 dB	10503A	
BBA	Cable, BNC	BNC male 23 cm (9 in) max	10502A	
<b>Signal Source</b>				
All	Synthesized Sweeper	<b>Frequency:</b> 10 MHz to 26.5 GHz <b>Harmonic level:</b> < - 40 dBc <b>Amplitude range:</b> 10 to - 20 dBm <b>Frequency Accuracy:</b> 0.02%	PSG <sup>a</sup>	83630B, 83640B, 83650B
BBA	Signal Generator	<b>Frequency:</b> 250 kHz to 40 MHz Amplitude: ~-10 dBm Flatness: < ±0.75 dB	E4438C	33250A
<b>Power Meter</b>				
All	Power Meter	<b>Power Reference Accuracy:</b> ±1.2% Compatible with power sensor	E4418B	E4419B
All	Power Sensor	<b>Frequency Range:</b> 50 MHz to 3.66 GHz <b>Amplitude Range:</b> -70 to -10 dBm	8481D	8487D 8485D
P03	Low Power Sensor	<b>Frequency Range:</b> 50 MHz to 3.6 GHz Amplitude Range: -70 to -10 dBm	8481D	8485D 8487D
Pxx other than P03	Low Power Sensor	<b>Frequency Range:</b> 50 MHz to 26.5 GHz Amplitude Range: -70 to -10 dBm	8485D	8487D
<b>Oscilloscope</b>				
All	Keysight Infiniium Oscilloscope	<b>Cutoff Frequency:</b> 50 MHz <b>Rejection at 65 MHz:</b> > 40 dB <b>Rejection at 75 MHz:</b> > 60 dB <b>Rejection at 80 MHz:</b> > 60 dB <b>Frequency:</b> 10 MHz to 26.5 GHz	54800B	

Functional Tests  
Test Equipment

Table 16-1

Analyzer Option	Item	Critical Specifications	Recommended Keysight Model	Alternate Keysight Model
<b>Miscellaneous Equipment</b>				
All	Filter, 50 MHz Low Pass	<b>Cutoff Frequency:</b> 50 MHz <b>Rejection at 65 MHz:</b> > 40 dB <b>Rejection at 75 MHz:</b> > 60 dB <b>Rejection at 80 MHz:</b> > 60 dB <b>Frequency:</b> 10 MHz to 26.5 GHz	0955-0306	
526	Power Splitter, 3.5 mm	<b>Nominal Insertion Loss:</b> 6 dB <b>Tracking Between Ports:</b> < 0.25 dB	11667B	
503, 508, 513	Power Splitter	<b>Nominal Insertion Loss:</b> 6 dB <b>Tracking Between Ports:</b> < 0.25 dB	11667A	11667B
All	Termination, 50W	Type N (m) Connector <b>Frequency:</b> 30 Hz to 26.5 GHz	909A Option 012	
BBA	Termination, 50W	BNC male <b>Frequency:</b> 250 kHz to 40 MHz	11593A	

- a. PSG model numbers: E8244A, E8254A, E8247C Option 520, E8247C Option H31 or 540, E8257D Option 520, E8257D Option 550, E8257D Option 567, E8267D Option 544.

## Displayed Average Noise Level (DANL)

### Test Limits (with 0 dB input attenuation)

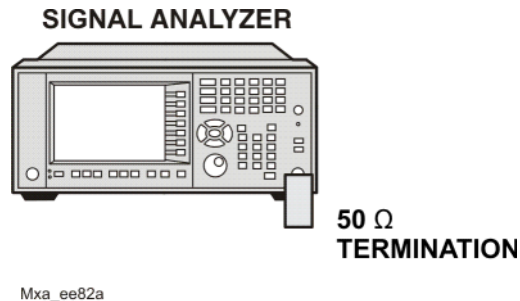
See [Table 16-2](#) for values.

The Displayed Average Noise Level (DANL) of the signal analyzer is measured across a 10 kHz frequency span at several center frequencies. The analyzer input is terminated into a 50Ω load. A test is performed to assure the measurement is not performed in the presence of a residual response. The measurement is then averaged, and the result is normalized to a 1 Hz bandwidth.

Table 16-2 DANL Measurement Requirements

Item	Critical Specifications (for this test)	Recommended Keysight Model
Termination, 50Ω Type-N (m)	Frequency: DC to 18 GHz	909A Option 012

Figure 16-1 DANL Test Setup



### Procedure

1. Configure the equipment as shown in [Figure 16-1](#)
2. Press **Mode, Spectrum Analyzer, Mode Preset** on the analyzer.
3. Set up the signal analyzer by pressing:

**FREQ Channel, Center Freq, 10, MHz**  
**Input/Output, RF Input, RF Coupling, select DC**  
**SPAN X Scale, Span, 10, kHz**  
**AMPTD Y Scale, -70, dBm**  
**AMPTD Y Scale, Attenuation, Mech Atten, 0, dB**  
**BW, Res BW, 1, kHz**  
**BW, Video BW, 100, Hz**  
**Meas Setup, Average/Hold, Number, 20, Enter**  
**Trace/Detector, Trace Average**

### Single

4. Press **Restart**, then wait for Average/Hold to display 20/20.
5. Press **View/Display, Display**, then press **Display Line, On**.
6. Rotate the knob and set the display line at the average amplitude of the displayed noise floor by visual inspection.
7. Confirm that the measurement is performed on the analyzer noise floor and not on a residual response within the displayed 10 kHz span.

**NOTE** Ignore the residual response if one appears when taking the measurement.

---

8. Enter the value of the display line as the Measured Average Noise Level at 10 MHz column in [Table 16-2 on page 604](#).
9. Normalize the measured value to a 1 Hz BW by adding -30 dB to the measured value.

**NOTE** The -30 dB value is added because the formula used to calculate the value of the noise power in a 1 Hz BW when measured with a 1 kHz BW is:

Normalized Noise = 10 Log (BW 2/BW 1) where BW 2 is the 1 kHz BW we measure and BW 1 is 1 Hz BW to which we want to normalize.

Therefore, 10 Log (1000) = 30 dB, so the noise floor will be 30 dB lower in a 1 Hz BW.

---

10. Enter the normalized value of the displayed average noise level in [Table 16-2 on page 604](#).
11. The value of the normalized displayed average noise should be less than the specification value.
12. Change the analyzer center frequency to the next value listed in [Table 16-2 on page 604](#). Press: **FREQ Channel, Center Freq**, [Table 2-1 Value], **GHz**
13. Repeat [step 7](#) through [step 12](#) to fill in the remainder of [Table 16-2 on page 604](#) for your analyzer frequency range.

Functional Tests  
Displayed Average Noise Level (DANL)

<b>Center Frequency</b>	<b>Measured Average Noise Level (dBm)</b>	<b>Normalized Average Noise Level/(1 Hz BW) (dBm)</b>	<b>Test Limits (dBm)</b>
10 MHz			-150
2 GHz			-150
6 GHz			-148
13 GHz			-147
20 GHz			-142
26.5 GHz			-135

## Frequency Readout Accuracy

### Test Limits

Frequency Readout Accuracy is equivalent to the following equation:

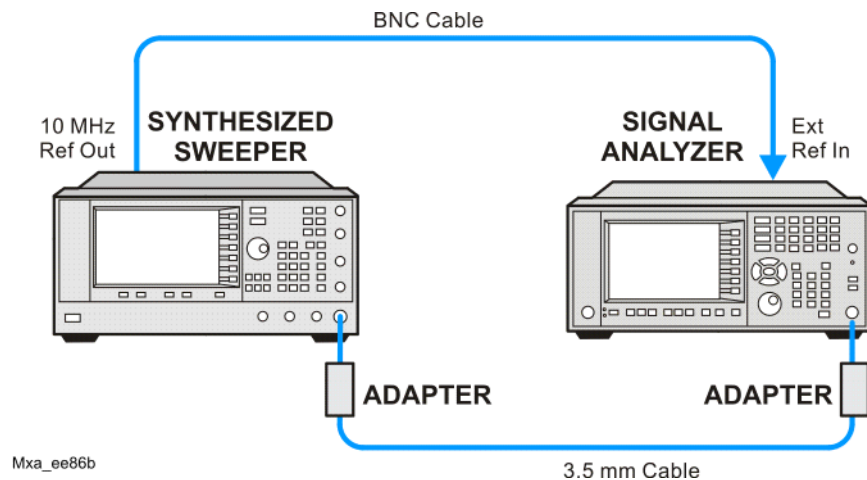
$$\pm(0.25\% \times \text{span} + 5\% \times \text{RBW} + 2 \text{ Hz} + 0.5 \times \text{horizontal resolution})$$

See results table for actual values.

The frequency readout accuracy is measured in several spans and center frequencies that allow both internal analyzer synthesizer modes and prefilter bandwidths to be tested. Frequency reference error is eliminated by using the same frequency standard for the analyzer and signal source.

Item	Critical Specification (for this test)	Recommended Keysight Model
Adapter, Type-N (m), to 3.5 mm (f)	Frequency: 10 MHz to 1.51 GHz VSWR: < 1.1:1	1250-1744
Adapter, 3.5 mm (f) to 3.5 mm (f)	Frequency: 10 MHz to 1.51 GHz VSWR: < 1.1:1	83059B
Cable, 3.5 mm, 1 meter	Frequency: 10 MHz to 1.51 GHz VSWR: < 1.4:1	11500E
Cable, BNC, 120 cm	Frequency: 10 MHz	10503A
Synthesized Sweeper	<b>Frequency:</b> 10 MHz to 1.51 GHz	PSG

Figure 16-2 Frequency Readout Accuracy Test Setup



### Procedure

1. Configure the equipment as shown in Figure 16-2. Confirm the analyzer's built-in auto alignment has been performed within the past 24 hours.

- On the synthesized sweeper, press **PRESET**, then set the controls as follows:

**FREQUENCY, 1505, MHz**  
**POWER LEVEL, -10, dBm**

- Set up the signal analyzer by pressing:

**Mode, Spectrum Analyzer**  
**Mode Preset**  
**Input/Output, More, Freq Ref In, External**  
**FREQ Channel, Center Freq, 1505, MHz**  
**SPAN X Scale, Span, 2990, MHz**  
**Trace/Detector, More, Detector, Sample**  
**Single**

- Press **Restart**.

Press **Peak Search** on the analyzer. If the instrument is functioning correctly, the marker reading in the active function block will be between the values listed in **Table 16-3**. Record the marker value in the Marker Frequency Readout column in **Table 16-3**.

- On the signal analyzer, change the span and center frequency as listed in **Table 16-3**.
- Change the synthesized sweeper frequency to match the center frequency of the analyzer.
- Repeat **step 4** through **step 6** until the Marker Frequency Readout column of **Table 16-3** is complete.

Table 16-3 Frequency Readout Accuracy Results

Span (MHz)	Center Frequency (MHz)	Minimum	Marker Frequency Readout	Maximum
2990	1505	1495.9 MHz		1514.1 MHz
127.2	1505	1504.56 MHz		1505.44 MHz
54.1	1505	1504.8122 MHz		1505.1878 MHz
7.95	1505	1504.97240 MHz		1505.0276 MHz
0.106	1505	1504.999630 MHz		1505.000370 MHz
1.98	517.59	517.58316 MHz		517.59684 MHz
1.98	832.50	832.49316 MHz		832.50684 MHz



## Second Harmonic Distortion (SHD)

### Test Limits

Applied Frequency	Mixer Level	Distortion
40 MHz	-10 dBm	< -55 dBc

This test checks the second harmonic distortion of the signal analyzer by tuning to twice the input frequency and examining the level of the distortion product. A low pass filter is inserted between the source and the signal analyzer to prevent the source second harmonic from artificially raising the second harmonic product displayed on the analyzer.

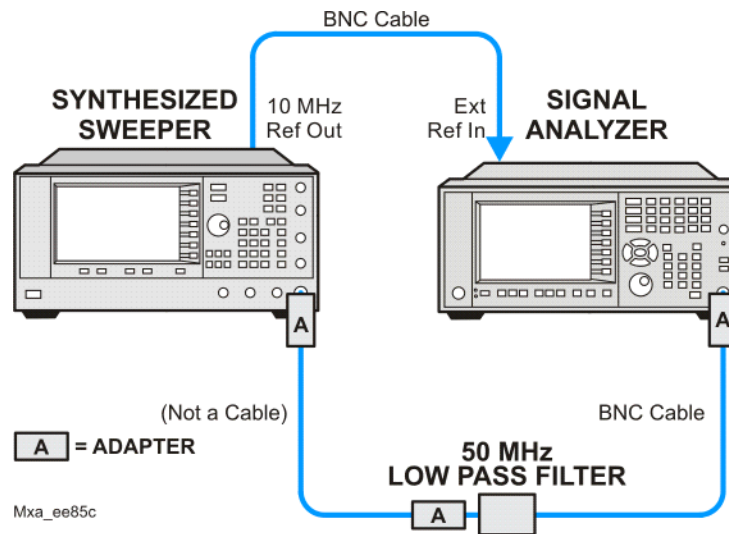
The power level at the input mixer is 20 dB higher than specified to allow the distortion product to be seen. For example, the instrument specification may state that with a -15 dBm signal at the input mixer, the distortion product should be suppressed by > -60 dBc.

The equivalent Second Harmonic Intercept (SHI) is 45 dBm (-15 dBm + 60 dBc). This test is performed with -10 dBm at the mixer and verifies the distortion product is suppressed by -55 dBc. This ensures the SHI is also 45 dBm (-10 dBm + 55 dBc).

Item	Critical Specifications (for this test)	Recommended Keysight Model
Adapter, Type-N(m) to BNC(f)	Frequency: 10 MHz to 80 MHz VSWR: < 1.05:1	1250-1476
Adapter, BNC(f) to SMA(m)	Frequency: 40 to 80 MHz	1250-1200
Adapter, 3.5 mm(f) to 3.5 mm(f)	Frequency: 10 MHz to 80 MHz VSWR: < 1.1:1	83059B
Cable, BNC 120 cm (2 required)	Frequency: 10 to 40 MHz	10503A
Filter, 50 MHz Low Pass	<b>Cutoff Frequency:</b> 50 MHz <b>Rejection at 65 MHz:</b> > 40 dB <b>Rejection at 75 MHz:</b> > 60 dB	0955-0306
Synthesized Sweeper	<b>Frequency:</b> 50 MHz <b>Spectral Purity:</b> Better than -30 dBc	PSG

Figure 16-3

Second Harmonic Distortion Test Setup



### Procedure

1. Configure the equipment as shown in [Figure 16-3](#).
2. Press **Mode, Spectrum Analyzer, Mode Preset** on the signal analyzer and Preset the synthesized sweeper.
3. Set up the synthesized sweeper by pressing:  
**Frequency, 40, MHz**  
**Amplitude, -10, dBm**
4. Set up the signal analyzer by pressing:  
**Input/Output, More, Freq Ref In, External**  
**FREQ Channel, Center Freq, 40, MHz**  
**SPAN X Scale, Span, 1, MHz**
5. On the analyzer, press **Peak Search**.
6. Adjust the synthesized sweeper amplitude for a signal analyzer display of  $-10 \text{ dBm} \pm 0.1 \text{ dB}$ .
7. On the analyzer, activate the marker delta function by pressing the **Marker** and **Delta** keys.
8. On the signal analyzer, press:  
**FREQ Channel, Center Freq, 80, MHz**  
**Meas Setup, Average/Hold Number, 20, Enter**  
**Trace/Detector, Trace Average**  
**Single**
9. Press **Peak Search**. Enter the displayed value under the Measured Second Harmonic Distortion (dBc) heading in [Table 16-4](#).

Functional Tests  
Second Harmonic Distortion (SHD)

Table 16-4 Second Harmonic Distortion Results

Applied Frequency (MHz)	Measured Second Harmonic Distortion (dBc)	Mixer Level (dBm)	Specification (dBc)
40		-10	-55

## Amplitude Accuracy at 50 MHz

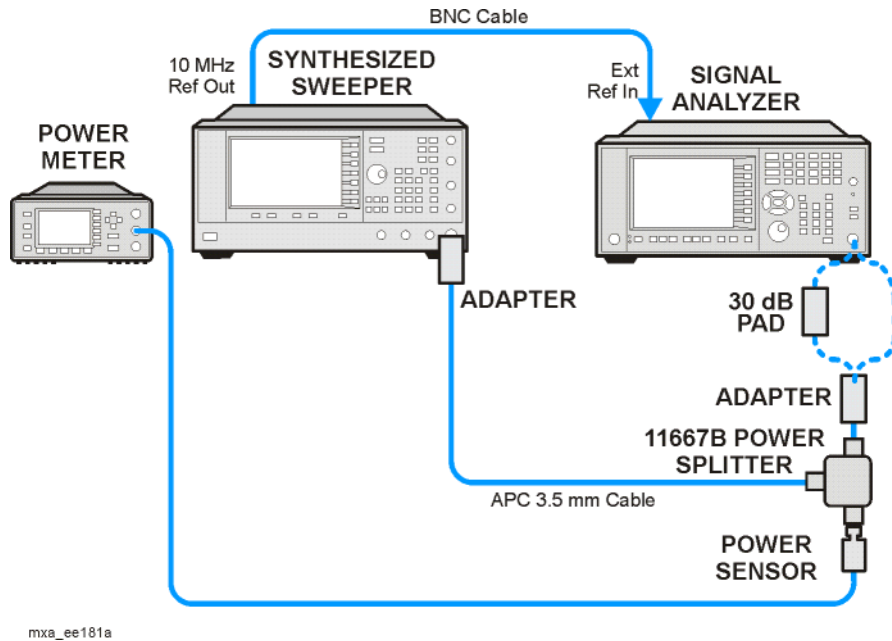
### Test Limits

Amplitude Accuracy should remain within 1.13 dB of the measured source value across the range of source levels and changes in resolution bandwidth. The Preamp (option P03, P08, P13, P26) should remain within  $\pm 1.3$  dB of measured values.

A synthesized sweeper is used as the signal source for the test. The source amplitude is varied using the signal source amplitude control. The attenuation and resolution bandwidth are varied on the signal analyzer. The source amplitude is measured by the power meter and signal analyzer at each setting, and the values compared. The difference between each pair of measurements indicates the amplitude accuracy.

Item	Critical Specifications	Recommended Keysight Model
Adapter	Type-N (m), to 3.5 mm (m)	1250-1743
Adapter	3.5 mm (f) to 3.5 mm (f)	83059B
Attenuator, 30 dB	<b>Accuracy:</b> < 0.5 dB at 50 MHz	11708A
Cable	3.5 mm, 1 meter	11500E
Cable	BNC, 120 cm	10503A
Power Meter	Compatible with power sensor	E4418B
Power Sensor	<b>Amplitude Range:</b> -25 dBm to 10 dBm	8485A
Power Splitter	3.5 mm (f) connectors 6 dB loss	11667B
Synthesized Sweeper	<b>Typical Temperature Stability:</b> 0.01 dBc/°C	PSG

Figure 16-4 Amplitude Accuracy Test Setup



## Procedure

1. Zero and calibrate the power meter.
2. Configure equipment as shown in [Figure 16-4](#), with the power splitter connected directly to the signal analyzer input through the adapter.

### CAUTION

To minimize stress on the test equipment connections, support the power sensor.

3. If the auto alignment for the analyzer has not been performed within the past 24 hours, press **System, Alignments, Align Now, All** to perform the auto alignment routine.
4. Press **Mode, Spectrum Analyzer, Mode Preset** on the analyzer.
5. Set up the synthesized sweeper by pressing:
  - CW, 50, MHz**
  - Power Level, -4, dBm**
  - RF (On)**
6. Set up the signal analyzer by pressing:
  - Input/Output, More, Freq Ref In, External**
  - FREQ Channel, Center Freq, 50, MHz**
  - SPAN X Scale, 2, MHz**
  - AMPTD Y Scale, Attenuation, Mech Atten, 10, dB**

**Input/Output, RF Input, RF Coupling, select DC Sweep/Control, Sweep Setup, Swp Time Rules, SA - Accuracy Meas Setup, Average/Hold Number, 20, Enter Trace/Detector, Trace Average Single**

7. Perform the following steps for each row listed in **Table 16-5**:
  - a. Set the synthesized sweeper amplitude to the value listed in the Nominal Source Amplitude column in **Table 16-5**
  - b. Set the Mech Atten as indicated in the Attenuation column in **Table 16-5**
  - c. Set the Span as listed in the Span column of **Table 16-5**
  - d. Record the source amplitude, as measured by the power meter, in the Power Meter Amplitude column of **Table 16-5**
  - e. On the signal analyzer, press **Restart**.
  - f. Wait for the signal analyzer to finish averaging.
  - g. Press Peak Search.
  - h. Record the signal amplitude, as measured by the analyzer in the Measured Amplitude column of **Table 16-5**
  - i. Calculate the signal amplitude accuracy error using the following equation, and record the results under the Amplitude Accuracy Error column:

$$\text{Amplitude Accuracy Error} = \text{Meas\_amp} - \text{Power\_meter}$$

Table 16-5 Amplitude Accuracy Results

Nominal Source Amplitude (dBm)	Attenuation (dB)	Span (MHz)	Measured Amplitude Meas_amp (dBm)	Power Meter Amplitude Power_meter (dBm)	Amplitude Accuracy Error (dB)	Test Limit (dB)
-4	10	2				±1.13 dB
-9	10	1				±1.13 dB
-14	10	0.5				±1.13 dB
-4	20	0.1				±1.13 dB
-14	20	0.1				±1.13 dB
-4	30	0.1				±1.13 dB
-14	30	0.1				±1.13 dB

## Testing Preamp Option (P03, P08, P13, P26)

Instruments containing Options P03, P08, P13, P26 must have the preamp function turned on and tested.

### Procedure

1. On the analyzer, press **AMPTD Y Scale, More, Internal Preamp, Low Band**.
2. Connect the equipment as shown in **Figure 16-4 on page 613**, using a 30 dB Pad between the adaptor and the signal analyzer input.
3. Set the synthesized sweeper amplitude to the value listed in the Nominal Source Amplitude column in **Table 16-6**.
4. Set the signal analyzer input attenuation to 0 dB.
5. Set the Span as listed in **Table 16-6**.
6. Record the source amplitude, as measured by the power meter, in the Power Meter Amplitude column of **Table 16-6**.
7. On the signal analyzer, press **Restart**.
8. Wait for the analyzer to finish averaging.
9. Press **Peak Search**.
10. Record the signal amplitude as measured by the analyzer in the measured amplitude column of **Table 16-6**.
11. Calculate the signal amplitude accuracy using the following equation:  

$$\text{Amplitude Accuracy Error} = \text{Meas\_amp} + 30 \text{ dB} - \text{Power\_meter}$$
12. Record the results under the Amplitude Accuracy Error column of **Table 16-6**

Table 16-6 Amplitude Accuracy Results (Option P03, P08, P13, P26)

Nominal Source Amplitude (dBm)	Low- band Preamp	Res BW (kHz)	Span (kHz)	Measured Amplitude Meas_amp (dBm)	Power Meter Amplitude Power_meter (dBm)	Amplitude Accuracy Error (dB)	Test Limit (dB)
-13	ON	1	106				±1.30 dB

## Frequency Response (Flatness)

### Test Limits

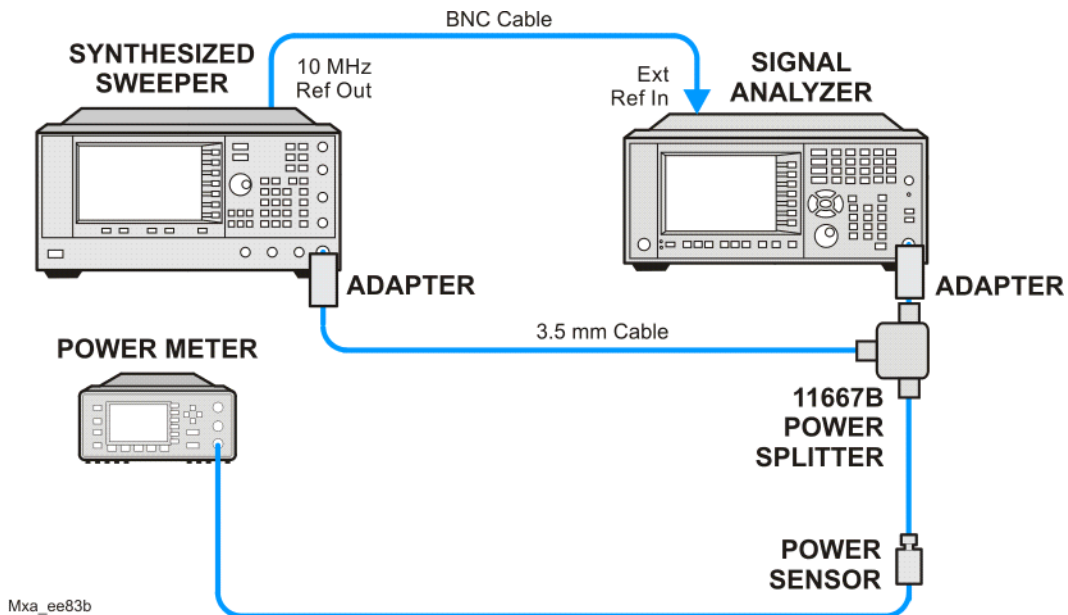
Frequency Range	Limit Relative to 50 MHz
20 Hz to 3.6 GHz	±1.5 dB
> 3.6 GHz to 8.4 GHz	±2.5 dB
> 8.4 GHz to 13.6 GHz	±3.0 dB
> 13.6 GHz to 26.5 GHz	±3.5 dB

The frequency response test measures the signal analyzer's amplitude error as a function of the tuned frequency. Measurements are made ranging from 50 MHz to the maximum frequency range of your analyzer. The signal source amplitude is measured with a power meter to eliminate error due to source flatness. The measured value is normalized to 50 MHz.

Item	Critical Specifications (for this test)	Recommended Keysight Model
Adapter, Type N (m) to 3.5 mm (m)	<b>Frequency:</b> 10 MHz to 18 GHz VSWR: < 1.1:1	1250-1743
Adapter, 3.5 mm (f) to 3.5 mm (f)	Frequency: 10 MHz to 26.5 GHz VSWR: < 1.1:1	83059B
Cable, 3.5 mm, 1 meter	Frequency: 10 MHz to 26.5 GHz VSWR: < 1.4:1	11500E
Cables, BNC 120 cm	Frequency: 10 MHz	10503A
Power Meter	Compatible with power sensor	E4418B
Power Sensor	<b>Frequency Range:</b> 50 MHz to 26.5 GHz	8485A
Power Splitter	<b>Frequency Range:</b> 50 MHz to 26.5 GHz <b>Tracking between ports:</b> < 0.25 dB	11667B
Synthesized Sweeper	<b>Frequency Range:</b> 50 MHz to 26 GHz	PSG



Figure 16-5 Frequency Response Test Setup



## Procedure

1. Zero and calibrate the power meter and power sensor as described in the power meter operation manual.
2. Configure the equipment as shown in [Figure 16-5](#).

**NOTE** Connect the power splitter to the signal analyzer input using the appropriate adapter. Do not use a cable.

3. Assure the signal analyzer's built-in auto alignment has been performed within the last 24 hours.
4. Press **Mode, Spectrum Analyzer, Mode Preset** on the signal analyzer, and press **Preset** on the synthesized sweeper.
5. Set up the synthesized sweeper by pressing:  
**CW, 50, MHz**  
**Power level, -4, dBm**
6. Set up the signal analyzer by pressing:  
**Input/Output, More, Freq Ref In, External**  
**FREQ Channel, Center Freq, 50, MHz**  
**SPAN X Scale, Span, 50, kHz**  
**AMPTD Y Scale, Ref Level, 0, dBm**

Functional Tests  
Frequency Response (Flatness)

7. Adjust the synthesized sweeper output power for a power meter reading of  $-10 \text{ dBm} \pm 0.1 \text{ dB}$ .
8. On the signal analyzer, press **Single**.
9. Press the **Peak Search** key on the signal analyzer to position the marker on the peak of the signal.
10. Refer to **Table 16-7, "Frequency Response (Flatness) Results."** Enter the amplitude of the signal displayed on the signal analyzer into the  $\text{Meas}_{\text{Amp}}$  column of **Table 16-7**.
11. Enter the power meter reading into the  $\text{Power}_{\text{Meter}}$  column of **Table 16-7**.
12. Tune the synthesized sweeper and signal analyzer to the next frequency listed in **Table 16-7**.
13. Enter the power sensor calibration factor into the power meter.
14. For frequencies 3.6 GHz and above, press **AMPTD Y Scale**, then **Presel Center** to center the preselector filter for an optimum amplitude measurement.
15. Repeat **step 7** through **step 14** and complete the remainder of **Table 16-7** for the frequency range of your analyzer.
16. Compute the measurement error ( $\text{Meas}_{\text{Error}} = \text{Meas}_{\text{Amp}} - \text{Power}_{\text{Meter}}$ ).
17. Compute the flatness error normalized to 50 MHz:  
( $\text{Meas}_{\text{Error}} - \text{Meas}_{\text{Error}} @ 50 \text{ MHz}$ )
18. Enter the computed flatness error value into the  $\text{Flat}_{\text{Norm}}$  column of **Table 16-7**.
19. Compare the value of  $\text{Flat}_{\text{Norm}}$  to the test limit.

Functional Tests  
 Frequency Response (Flatness)

Table 16-7 Frequency Response (Flatness) Results

Center Frequency	Analyzer Amplitude $Meas_{amp}$	Power Meter Measurement $Power_{meter}$	Meas Error $Meas_{error}$	Flatness Normalized to 50 MHz $Flat_{Norm}$	Flatness Error Test Limits (dB)
50 MHz				0	Ref
1 GHz					$\pm 1.5$ dB
2 GHz					1.5 dB
3 GHz					$\pm 1.5$ dB
3.5 GHz					$\pm 1.5$ dB
4 GHz					$\pm 2.5$ dB
6 GHz					$\pm 2.5$ dB
8 GHz					$\pm 2.5$ dB
9 GHz					$\pm 3.0$ dB
11 GHz					$\pm 3.0$ dB
13 GHz					$\pm 3.0$ dB
14 GHz					$\pm 3.5$ dB
17 GHz					$\pm 3.5$ dB
20 GHz					$\pm 3.5$ dB
23 GHz					$\pm 3.5$ dB
26 GHz					$\pm 3.5$ dB

## Frequency Response (Flatness), Preamp On

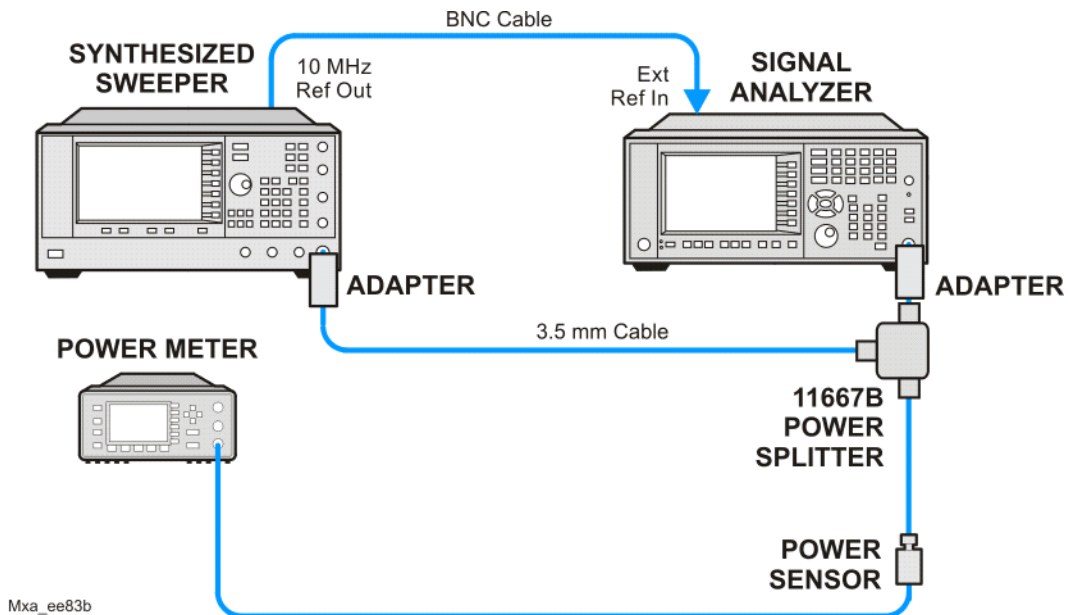
### Test Limits

Frequency Range	Limit Relative to 50 MHz
100 kHz to 3.6 GHz	±2.0 dB
> 3.6 GHz to 8.4 GHz	±3.0 dB
> 8.4 GHz to 13.6 GHz	±3.5 dB
> 13.6 GHz to 26.5 GHz	±4.0 dB

The frequency response test, with preamplifier on, measures the signal analyzer's amplitude error as a function of the tuned frequency. Measurements are made ranging from 50 MHz to the maximum frequency range of the preamp. The signal source amplitude is measured with a power meter to eliminate error due to source flatness. The measured value is normalized to 50 MHz.

Item	Critical Specifications (for this test)	Recommended Keysight Model
Adapter, Type N(m) to 3.5 mm(m)	Frequency: 10 MHz to 18 GHz VSWR: < 1.1:1	1250-1743
Adapter, 3.5 mm(f) to 3.5 mm(f)	Frequency: 10 MHz to 26.5 GHz VSWR: < 1.1:1	83059B
Cable, 3.5 mm, 1 meter	Frequency: 10 MHz to 26.5 GHz VSWR: < 1.4:1	11500E
Cables, BNC 120 cm	Frequency: 10 MHz	10503A
Power Meter	Compatible with power sensor	E4418B
Attenuator, 30 dB Fixed	Frequency: 50 MHz Accuracy: ±0.05 dB	11708A
Power Sensor	<b>Frequency Range:</b> 50 MHz to 26.5 GHz <b>Amplitude Range:</b> -65 dBm to -55 dBm	8485D
Power Splitter	<b>Frequency Range:</b> 50 MHz to 26.5 GHz <b>Tracking between ports:</b> < 0.25 dB	11667B
Synthesized Sweeper	<b>Frequency Range:</b> 50 MHz to 26.5 GHz	PSG

Figure 16-6 Frequency Response Test Setup



## Procedure

1. Zero and calibrate the power meter and power sensor as described in the power meter operation manual.
2. Configure the equipment as shown in [Figure 16-6](#).

**NOTE** Connect the power splitter to the signal analyzer input using the appropriate adapter. Do not use a cable.

3. Assure the signal analyzer's built-in auto alignment has been performed within the last 24 hours.
4. Press **Mode, Spectrum Analyzer, Mode Preset** on the signal analyzer, and press **Preset** on the synthesized sweeper.
5. Set up the synthesized sweeper by pressing:  
**CW, 50, MHz**  
**Power level, -54, dBm**
6. Set up the signal analyzer by pressing:  
**Input/Output, More, Freq Ref In, External**  
**FREQ Channel, Center Freq, 50, MHz**  
**SPAN X Scale, Span, 50, kHz**  
**AMPTD Y Scale, More, Internal Preamp, Full Range**  
**AMPTD Y Scale, Attenuation, Mech Atten, 0, dB**

**AMPTD Y Scale, Ref Level, -55, dBm**

7. Adjust the synthesized sweeper output power for a power meter reading of  $-60 \text{ dBm} \pm 0.1 \text{ dB}$ .
8. On the signal analyzer, press **Single**.
9. Press the **Peak Search** key on the signal analyzer to position the marker on the peak of the signal.
10. Refer to **Table 16-7, "Frequency Response (Flatness) Results."** Enter the amplitude of the signal displayed on the signal analyzer into the  $\text{Meas}_{\text{Amp}}$  column of **Table 16-7**.
11. Enter the power meter reading into the  $\text{Power}_{\text{Meter}}$  column of **Table 16-7**.
12. Tune the synthesized sweeper and signal analyzer to the next frequency listed in **Table 16-7**.
13. Enter the power sensor calibration factor into the power meter.
14. For frequencies 3.6 GHz and above, press **AMPTD Y Scale**, then **Presel Center** to center the preselector filter for an optimum amplitude measurement.
15. Repeat **step 7** through **step 14** and complete the remainder of **Table 16-7** for the frequency range of your preamp.
16. Compute the measurement error ( $\text{Meas}_{\text{Error}} = \text{Meas}_{\text{Amp}} - \text{Power}_{\text{Meter}}$ ).
17. Compute the flatness error normalized to 50 MHz:  
( $\text{Meas}_{\text{Error}} - \text{Meas}_{\text{Error}} @ 50 \text{ MHz}$ )
18. Enter the computed flatness error value into the  $\text{Flat}_{\text{Norm}}$  column of **Table 16-7**.
19. Compare the value of  $\text{Flat}_{\text{Norm}}$  to the test limit.

Functional Tests  
 Frequency Response (Flatness), Preamp On

Table 16-8 Frequency Response (Flatness) Results

Center Frequency	Analyzer Amplitude $Meas_{amp}$	Power Meter Measurement $Power_{meter}$	Meas Error $Meas_{error}$	Flatness Normalized to 50 MHz $Flat_{Norm}$	Flatness Error Test Limits (dB)
50 MHz				0	Ref
1 GHz					$\pm 2.0$ dB
2 GHz					$\pm 2.0$ dB
3 GHz					$\pm 2.0$ dB
3.5 GHz					$\pm 2.0$ dB
4 GHz					$\pm 3.0$ dB
6 GHz					$\pm 3.0$ dB
8 GHz					$\pm 3.0$ dB
9 GHz					$\pm 3.5$ dB
11 GHz					$\pm 3.5$ dB
13 GHz					$\pm 3.5$ dB
14 GHz					$\pm 4.0$ dB
17 GHz					$\pm 4.0$ dB
20 GHz					$\pm 4.0$ dB
23 GHz					$\pm 4.0$ dB
26 GHz					$\pm 4.0$ dB

## Scale Fidelity

### Test Limits

The scale fidelity error will be  $\pm 1.0$  dB with  $-10$  dBm at the mixer.

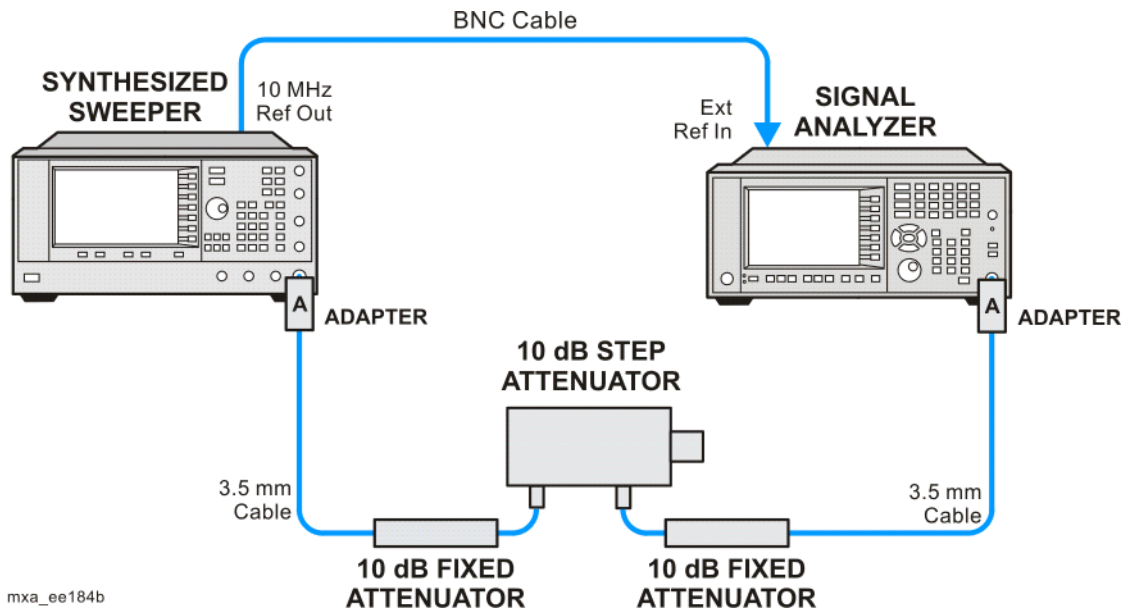
This test checks the scale fidelity of the instrument by maintaining a constant reference level and measuring signals of different amplitudes over most of the display range. This test sets the input attenuator to 10 dB and the Reference Level to 0 dBm. The external attenuator is set to 0 dB, and the amplitude of the source is adjusted to set the displayed signal at the reference level.

The instrument's internal marker is used to measure the reference amplitude. The Marker Delta function is activated and the RF input is reduced using the external precision step attenuator. Signal input levels from 0 dBm to -50 dBm are measured.

Item	Critical Specifications (for this test)	Recommended Keysight Model
Adapter, Type-N (m), to 3.5 mm (f)	Frequency: 10 MHz to 18 GHz VSWR: < 1.1:1	1250-1745
Adapter, 3.5 mm (f) to 3.5 mm (f)	Frequency: 10 MHz to 26.5 GHz VSWR: < 1.1:1	83059B
Attenuator, 10 dB Step	<b>Range:</b> 0-50 dB <b>Frequency:</b> 50 MHz <b>Accuracy:</b> $\pm 0.25$ dB	8495A
Attenuator, 10 dB fixed (2 required)	Frequency: 50 MHz VSWR: < 1.2:1	8493C, option 010
Cable, 3.5 mm, 1 meter (2 required)	Frequency: 10 MHz to 26.5 GHz VSWR: < 1.4:1	11500E
Cable, BNC 120 cm	Frequency: 10 MHz	10503A
Synthesized Sweeper	<b>Output Level Accuracy:</b> 0 to -15 dBm: $\pm 1.0$ dB	PSG



Figure 16-7 Scale Fidelity Setup



**NOTE** Averaging is used for all measurements to improve repeatability and reduce measurement uncertainty.

## Procedure

1. Configure the equipment as shown in [Figure 16-7](#).
2. Preset the Source and press **Mode, Spectrum Analyzer, Mode Preset** on the analyzer.
3. Set up the synthesized sweeper by pressing:
  - Frequency, 50, MHz**
  - Amplitude, +5, dBm**
  - RF On/Off, On**
4. Set up the signal analyzer by pressing:
  - Input/Output, More, Freq Ref In, External**
  - FREQ Channel, Center Freq, 50, MHz**
  - SPAN X Scale, Span, 1, MHz**
  - AMPTD Y Scale, Ref Level, 0, dBm**
  - Meas Setup, Average/Hold Number, 10, Enter**
  - Trace/Detector, Trace Average**
  - Peak Search**
5. Set the external 10 dB step attenuator to 0 dB.

6. Adjust the amplitude on the signal source until the marker amplitude on the analyzer reads  $-15 \text{ dBm} \pm 0.2 \text{ dB}$ .
7. On the analyzer, press the **Single, Restart** to trigger a 10 sweep average.
8. On the analyzer, activate the Marker Delta function by pressing **Peak Search, Marker Delta**.
9. Perform the following steps for each attenuator setting listed in the table below:
  - a. Select the next External attenuator setting.
  - b. Press the **Restart** key to trigger a 10 sweep average.
  - c. Enter the delta marker value into **Table 16-9**.
  - d. Check delta marker reading against the test limits.

Functional Tests  
Scale Fidelity

Table 16-9 Scale Fidelity Results

External Attenuator Setting	Minimum (dB)	Marker Delta Value (dB)	Maximum (dB)
0	N/A	Reference	N/A
10	-11.0		-9.0
20	-21.0		-19.0
30	-31.0		-29.0
40	-41.0		-39.0
50	-51.0		-49.0

## BBIQ Input Frequency Response (Option BBA only)

### Test Limits

Frequency Range	Limit Relative to 250 kHz
Frequency Range	Limit Relative to 250 kHz
250 kHz to 10 MHz (Standard)	$\pm 1.75$ dB
250 kHz to 25 MHz (Option B25)	$\pm 1.75$ dB
250 kHz to 40 MHz (Option S40 or SU1)	$\pm 1.75$ dB

This procedure tests the amplitude response of each of the BBIQ inputs versus frequency. For each input, a reference measurement is made at 250 kHz and then subsequent measurements are made at several frequencies up to the maximum IQ bandwidth. The amplitude difference between the measurement at 250 kHz and subsequent frequencies is calculated and compared to the test limit.

Item	Critical Specifications	Recommended Keysight Model
RF Signal Generator	Frequency: 250 kHz to 40 MHz Amplitude: $\sim -10$ dBm Flatness: $< \pm 0.75$ dB	E4438C
Cable, BNC	Connectors: BNC male Length: 23 cm (9 in) max	10502A
Cable, BNC, 120 cm	Connectors: BNC male Frequency: 250 kHz to 40 MHz	10503A
50 Ohm Termination	Connector: BNC male Frequency: 250 kHz to 40 MHz	11593A

Figure 16-8 BBIQ Input Frequency Response Setup (I Input)

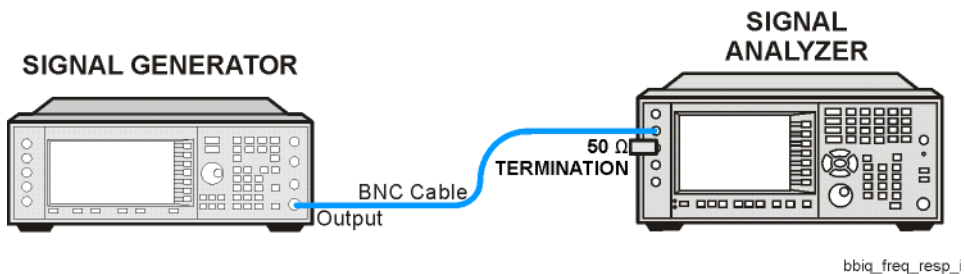


Figure 16-9 BBIQ Input Frequency Response Setup (I Input)

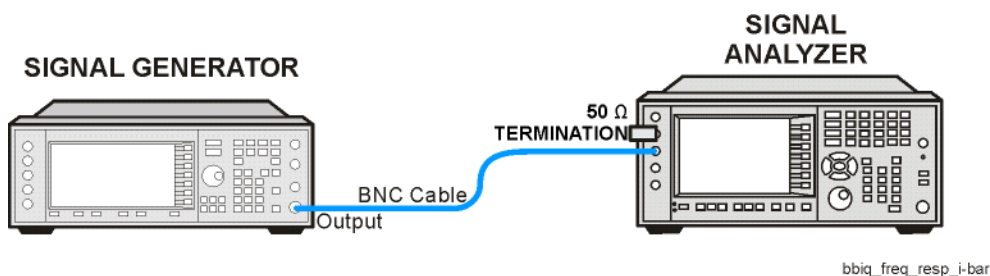


Figure 16-10 BBIQ Input Frequency Response Setup (Q Input)

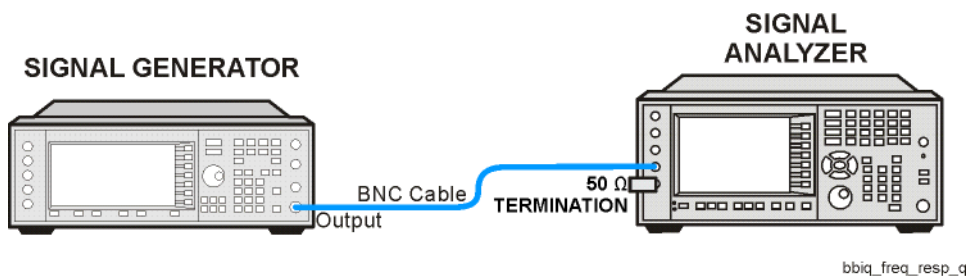
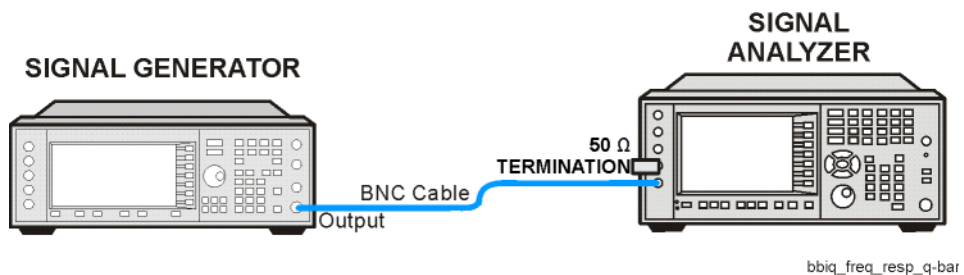


Figure 16-11 BBIQ Input Frequency Response Setup (Q Input)



## Procedure

1. On the X-Series analyzer, press **Mode, IQ Analyzer** (Basic). Press **Mode Preset**.
2. Press **Input/Output, I/Q** (to change to I/Q inputs), **I/Q** (to bring up the I/Q input menu), **I/Q Cable Calibrate**. Follow the instructions on screen. Use the short BNC cable listed above to perform the calibration. This process has several steps and will take about 3 minutes to perform.
3. Press **I/Q Path, I+jQ, I Setup, Differential** (On). Press **Return, Q Setup, Q Same as I** (Yes).
4. Preset the RF Signal Generator and set the controls as follows:

Frequency	250 kHz
Amplitude	-10 dBm
RF	On

### NOTE

Once the RF Signal Generator's Amplitude is set, do not change the RF Signal Generator's Amplitude setting during the rest of this procedure.

---

5. Connect the longer BNC cable between the RF Signal Generator's RF OUTPUT and the I input of the X-Series analyzer, see [Figure 16-7](#)
  6. Connect the 50 Ohm termination to the I input of the X-Series analyzer, see [Figure 16-7](#)
  7. Press **Mode Preset** on the X-Series analyzer. Press **System, Show, System**. Note if either of the options listed below are present:
    - N9020A-B25
    - N9020A-S40
    - N9020A-SU1
  8. If none of the options listed in [step 7](#) are present, the maximum IQ bandwidth is 10 MHz
  9. If N9020A-B25 is present, but N9020A-S40 and N9020A-SU1 are not present, the maximum IQ bandwidth is 25 MHz
  10. If either N9020A-S40 or N9020A-SU1 is present, the maximum IQ bandwidth is 40 MHz.
  11. Press **FREQ** on the X-Series analyzer and set the Center Freq equal to one half the maximum IQ bandwidth determined above. For example, if the maximum IQ bandwidth is 40 MHz, set the Center Freq to 20 MHz.
  12. Press **SPAN** on the X-Series analyzer and set the Span equal to the maximum IQ bandwidth determined above.
  13. Press **BW** on the X-Series analyzer and set the Res BW to 100 kHz.
-

**14.** Press **Peak Search** on the X-Series analyzer. Record the marker amplitude reading in **Table 16-10** for the I Input at 250 kHz.

**15.** Set the RF Signal Generator to each of the remaining frequencies listed in Table 1, up to the maximum IQ bandwidth of the X-Series analyzer. At each frequency, do the following:

- a. Press **Peak Search**
- b. Record the marker amplitude reading in **Table 16-10** for the I Input at the current RF Signal Generator frequency

Table 16-10 BBIQ Input Frequency Response, I and I Inputs

RF Signal Generator Frequency	I Input		I Input		Test Limits
	Marker Amplitude	Frequency Response	Marker Amplitude	Frequency Response	
250 kHz		0.0 dB		0.0 dB	±1.75 dB
2 MHz					±1.75 dB
5 MHz					±1.75 dB
7.5 MHz					±1.75 dB
9.9 MHz					±1.75 dB
Stop here if Maximum IQ Bandwidth is 10 MHz					
12.5 MHz					±1.75 dB
15 MHz					±1.75 dB
17.5 MHz					±1.75 dB
20 MHz					±1.75 dB
22.5 MHz					±1.75 dB
24.9 MHz					±1.75 dB
Stop here if Maximum IQ Bandwidth is 25 MHz					
30 MHz					±1.75 dB
35 MHz					±1.75 dB
39.9 MHz					±1.75 dB

**16.** Set the RF Signal Generator frequency to 250 kHz

**17.** Connect the BNC Cable between the RF Signal Generator RF Output and the I input on the X-Series analyzer, see **Figure 16-9**

**18.** Connect the 50 Ohm termination to the I input on the X-Series analyzer, see **Figure 16-9**

19. Press **Peak Search** on the X-Series analyzer. Record the marker amplitude reading in **Table 16-10** for the I Input at 250 kHz.
20. Set the RF Signal Generator to each of the remaining frequencies listed in Table 1, up to the maximum IQ bandwidth of the X-Series analyzer. At each frequency, do the following:
  - a. Press **Peak Search**
  - b. Record the marker amplitude reading in **Table 16-10** for the I Input at the current RF Signal Generator frequency

**NOTE**

Since the input is set for I + Q and the input signal is being applied to I only, the analyzer will measure 6 dB lower than the signal generator output; in this case

$$-10 \text{ dB} - +6 \text{ dB} = -16 \text{ dB}$$

This will be the case for I, I, Q, and Q inputs.  
This is because the Fourier transform of

$$A \sin(w+) = A_m(W-w) + 1/2 A_m(W+w).$$

Since a signal is placed at  $w$  or  $-w$ , the result will be  $20\log(1/2)$  lower.  
The transform is in voltage and not power.

---

21. Connect the BNC Cable between the RF Signal Generator RF Output and the Q input on the X-Series analyzer, see **Figure 16-10**
22. Connect the 50 Ohm termination to the Q input on the X-Series analyzer, see **Figure 16-10**
23. Set the RF Signal Generator frequency to 250 kHz.
24. Press **Peak Search** on the X-Series analyzer. Record the marker amplitude reading in **Table 16-11** for the Q Input at 250 kHz.
25. Set the RF Signal Generator to each of the remaining frequencies listed in **Table 16-11**, up to the maximum IQ bandwidth of the X-Series analyzer. At each frequency, do the following:

Press **Peak Search**

Record the marker amplitude reading in **Table 16-11** for the Q Input at the current RF Signal Generator frequency



Table 16-11 BBIQ Input Frequency Response, Q and Q Inputs

RF Signal Generator Frequency	I Input		I Input		Test Limits
	Marker Amplitude	Frequency Response	Marker Amplitude	Frequency Response	
250 kHz		0.0 dB		0.0 dB	±1.75 dB
2 MHz					±1.75 dB
5 MHz					±1.75 dB
7.5 MHz					±1.75 dB
9.9 MHz					±1.75 dB
<b>Stop here if Maximum IQ Band width is 10 MHz</b>					
12.5 MHz					±1.75 dB
15 MHz					±1.75 dB
17.5 MHz					±1.75 dB
20 MHz					±1.75 dB
22.5 MHz					±1.75 dB
24.9 MHz					±1.75 dB
<b>Stop here if Maximum IQ Band width is 25 MHz</b>					
30 MHz					±1.75 dB
35 MHz					±1.75 dB
39.9 MHz					±1.75 dB

26. Set the RF Signal Generator frequency to 250 kHz
27. Connect the BNC Cable between the RF Signal Generator RF Output and the Q input on the X-Series analyzer, see [Figure 16-11](#)
28. Connect the 50 Ohm termination to the Q input on the X-Series analyzer, see [Figure 16-11](#)
29. Press **Peak Search** on the X-Series analyzer. Record the marker amplitude reading in [Table 16-11](#) for the Q Input at 250 kHz.
30. Set the RF Signal Generator to each of the remaining frequencies listed in [Table 16-11](#), up to the maximum IQ band width of the X-Series analyzer. At each frequency, do the following:
  - a. Press **Peak Search**
  - b. Record the marker amplitude reading in [Table 16-11](#) for the Q Input at the current RF Signal Generator frequency

Functional Tests

BBIQ Input Frequency Response (Option BBA only)

**31.**In **Table 16-10** and **Table 16-11**, calculate the Frequency Response for each input by subtracting the Marker Amplitude at 250 kHz for that input from the Marker Amplitude for each frequency greater than 250 kHz.

$$\text{Frequency Response} = \text{Marker Amplitude (Freq > 250 kHz)} - \text{Marker Amplitude (250 kHz)}$$

**32.**Compare the Frequency Response values to the Test Limits.

## 17 Instrument Software

### What You Will Find in This Chapter

[Instrument Software Overview on page 636](#)

[Software Licensing on page 637](#)

[Software Updates on page 638](#)

[Instrument Measurement Application Software on page 638](#)

[89601 VSA Software on page 638](#)

## Instrument Software Overview

The instrument software, installed in every instrument, contains not only the spectrum analyzer measurement application, but also all of the other currently available measurement applications. However, only the licensed applications will be seen and available for use.

To view the currently licensed measurement applications press **System, Show, System**. In addition to listing the application model number and description you will also see the revision of each. However, the complete package itself also has a revision associated with it, which can also be found on this screen as the "Firmware Revision".

Since the instrument application software is distributed in one complete package, when an update is installed they are all updated at the same time. One of the benefits of this is that you cannot have revisions that are incompatible with each other installed in an instrument. However, there is one exception to this, which would be the 89601A/B VSA software. While the latest revision of the 89601A/B VSA software is installed in each instrument as it left the factory, it must be updated, and kept in sync with the rest of the instrument application software independently.

## Software Licensing

All application software needs to have a valid license in order to be available for use. This also includes the spectrum analyzer application (N9060A or N9060B).

## Software Updates

### Instrument Measurement Application Software

Updates are installed much like most other types of commercial software packages. The latest revision of the software, along with complete installation instructions, can be obtained as follows:

**Web Download:**

The latest revision of the software can be downloaded from:

[www.keysight.com/find/xseries\\_software](http://www.keysight.com/find/xseries_software)

### 89601 VSA Software

Updates for the 89601 VSA software can be downloaded from:

<http://sa.tm.keysight.com/89600/Software>

The revision of the 89601 VSA software must be compatible with the revision of the instrument measurement application software package that is installed in the instrument. To determine what revisions are compatible, and if a further updates are required, please see the software compatibility information on the instrument measurement application software download web page listed above.

## Index

RF front end  
see A13 RF front end assembly

## Numerics

50 ohm load, 17  
50 ohm/75 ohm minimum loss  
pad, 17  
75 ohm matching transformer, 17

## A

A10 input attenuator  
description, 142  
high band troubleshooting, 185  
low band troubleshooting, 158  
part number, 366  
removal, 474  
A11 low band switch  
description, 142  
high band troubleshooting, 189  
low band troubleshooting, 162  
part number, 366  
removal, 450, 454, 458  
A12 YTF  
description, 142  
high band troubleshooting, 190  
low band troubleshooting, 163  
part number, 366  
removal, 476  
A13 RF front end assembly  
description, 144  
removal, 479  
A14 L.O. synthesizer assembly  
description, 143, 280  
high band troubleshooting, 180  
low band troubleshooting, 153  
part number, 366  
removal, 484  
troubleshooting, 282  
A15 front end control assembly  
description, 145, 208  
high band troubleshooting, 183  
low band troubleshooting, 156  
part number, 366  
removal, 481  
troubleshooting, 212  
A16 reference assembly  
description, 290  
high band troubleshooting, 178  
low band troubleshooting, 151  
part number, 366  
removal, 487  
troubleshooting, 293  
A17 BBIQ LED Board  
description, 333  
A18 BBIQ Interface Board

description, 333  
A19 BBIQ Main Board  
description, 334  
A1A2 front panel interface board  
description, 332  
part number, 366  
removal, 540, 548  
A1A3 LCD  
description, 332  
part number, 366  
removal, 537, 546  
troubleshooting, 59  
A1A4 inverter board  
part number, 366  
removal, 540, 548  
A1A4 LCD Inverter Board  
description, 332  
A1A5 front panel daughter board  
part number, 366  
removal, 540, 548  
A1A5 Front Panel USB Interface Board  
description, 332  
A2 analog IF assembly  
description, 232, 251  
part number, 366  
removal, 511  
troubleshooting, 236, 255  
A25 Wide Band Analog IF assembly  
removal, 516  
A26 Wide Band Digital IF assembly  
removal, 516  
A3 digital IF assembly  
description, 243, 262  
part number, 366  
removal, 511  
troubleshooting, 246, 265  
A4 CPU assembly  
description, 306  
part number, 366  
removal, 495  
troubleshooting, 306  
A4BT1 CPU board battery  
part number, 366  
post-repair setup, 563  
replacement, 495  
A5 disk drive  
description, 308  
troubleshooting, 308  
A5 hard disk drive  
part number, 366  
recovery process, 312  
removal, 498  
A6 power supply  
description, 316  
part number, 366  
removal, 492  
troubleshooting, 322  
A7 midplane  
description, 324  
part number, 366  
troubleshooting, 327

A7 midplane assembly  
part number, 366  
A8 motherboard  
description, 330  
part number, 366  
removal, 521  
troubleshooting, 331  
A9 input attenuator  
description, 142  
high band troubleshooting, 185  
low band troubleshooting, 158  
part number, 366  
removal, 474  
AC probe, 17  
access to service menus, 347  
accessories, 16  
50 ohm load, 17  
50 ohm/75 ohm minimum loss  
pad, 17  
75 ohm matching transformer, 17  
AC probe, 17  
broadband preamplifiers, 17  
power splitters, 18  
RF limiters, 18  
transient limiters, 18  
adjustments  
equipment, 26  
required test equipment, 26  
test equipment, 26  
after repairs  
see post-repair procedures, 562  
Agilent Technologies  
Sales and Service offices, 39  
splash screen, 48  
Align menu description, 358  
alignment failure, 64  
Alignments key, 46  
amplifiers, 17  
amplitude accuracy test, 612  
option 1DS, 615  
amplitude linearity test, 624  
analog IF  
see A2 analog IF assembly  
application updating, 636  
attenuators, removal, 474

## B

B1, B2 fans  
part number, 366  
removal, 526  
troubleshooting, 55  
backlights, 60  
bail handle  
part number, 366  
removal, 442  
Band Lock menu description, 356  
basics, troubleshooting, 46  
battery

- see A4BT1 CPU board battery
- BBIQ
  - description, 333
  - Interface Board description, 333
  - LED Board description, 333
  - Main Board description, 334
- BBIQ frequency response, 628
- BBIQ Interface Board removal, 552
- BBIQ Main Board, Option BBA removal
  - A19 Main Board, Option BBA removal
    - , 558
- BBIQ removal, 549
- before troubleshooting, 19
- BIOS settings verification, 572
- blank display, 59
- block diagrams, 336
- boot priority, 576
- boot process
  - problems, 51
- boot up process, 47
- broadband preamplifiers, 17

## C

- cables
  - part numbers, 366
- calibration application software, 23
- call centers, 39
- cautions and warnings, 19
- chassis parts
  - part numbers, 366
- checking firmware revision, 46
- computer block diagram, 336
- connector
  - see RF input connector
- contacting Keysight, 39
- corrections menu description, 354
- CPU assembly
  - see A4 CPU assembly

## D

- DANL test, 604
- daughter board
  - see A1A5 front panel daughter board
- DC probes
  - use of, 17
- diagnostics menus, 347
- digital IF
  - see A3 digital IF assembly
- disk drive
  - see A5 hard disk drive
- disk drive recovery process, 312
- display
  - see A1A3 LCD
- display output, rear panel, 59
- displayed average noise level. See DANL, 604
- dress case
  - see outer case

## E

- electronic attenuator path, 140
- electrostatic discharge, 21
- enabling spread spectrum, 578, 583, 587, 588
- entitlement certificate, 14
- equipment
  - adjustments, 26
  - functional tests, 601
  - performance verification tests, 26
  - warm-up time, 600
- error messages, 46, 73
- error queues
  - front panel, 76
- ESD Information, 21
- ESD safety accessories, 18
- external hardware, 382, 383, 384, 385, 390, 392, 394, 396, 398, 400, 402, 404, 417, 419, 420, 421, 422, 424, 425, 426, 430, 433, 482, 541, 542, 543
- external VGA monitor, 59

## F

- fans
  - see B1, B2 fans
- firmware, 46
- firmware revision, checking, 46
- firmware updating, 636
- frequency ranges, 138
- frequency readout accuracy test, 607
- frequency response (flatness) test, 616
- BBIQ, 628
- frequency response (flatness) test
  - preamp on, 620
- front end assembly
  - see A13 RF front end assembly
- front end control board
  - see A15 front end control assembly
- front end troubleshooting kit, 24
- front frame
  - description, 332
  - part number, 366
  - removal, 531
- front panel error queue, 76
- front panel interface
  - see A1A2 front panel interface board, 366
- functional testing
  - performance verification, 599
- functional tests, 46
  - before performing, 600
  - equipment list, 601
  - introduction, 599
  - vs performance verification tests, 599
  - warm-up time, 600
  - See also individual functional tests, 599
- Functional Tests Guide on CD-ROM, 16

## G

- Getting Started Guide on CD-ROM, 16
- green LED, 48

## H

- handle
  - see bail handle
- hard disk drive
  - see A5 hard disk drive
- hardware
  - external, 382, 383, 384, 385, 390, 392, 394, 396, 398, 400, 402, 404, 417, 419, 420, 421, 422, 424, 425, 426, 430, 433, 482, 541, 542, 543
- high band path, 138
- high band signal level verification, 71
- high band troubleshooting, 174, 178

## I

- IF Flatness menu description, 354
- initial alignment failure, 64
- initialization problem, 63
- input attenuators
  - see A9 and A10 input attenuator
- input connector
  - see RF input connector
- instrument
  - return for service, 43
- instrument frequency ranges, 138
- instrument messages, 73
- Instrument Messages Guide on CD-ROM, 16
- instrument options, 15
- instrument packaging, 43
- instrument serial number, 42
- instrument upgrade, 15
- internal alignments, 64
- inverter board
  - see A1A4 inverter board
- Inverter Board, Option BBA removal
  - A1A4 Inverter Board, Option BBA removal
    - , 550

## K

- keyboard
  - USB, 25
- keypad
  - part number, 366
  - removal, 540, 548
- Keysight Technologies
  - contacting, 39

## L

- LCD



- see A1A3 LCD
- LED
  - front panel, 46
  - green, 48
  - power on, 53
  - standby, 51
  - yellow, 48, 51
- LED Board removal
  - A18 BBIQ Interface Board removal
  - A17 BBIQ LED Board removal, 552
- license key, 14
- licensing software, 637
- limiters
  - RF and transient, 18
- LO Band Lock menu description, 357
- load, 50 ohm, 17
- loading MXA software, 311
- low band path, 138
- low band preamplifier path, 140
- low band signal level verification, 70
- low band switch
  - see A11 low band switch
- low band troubleshooting, 146

## M

- major assembly locations, 439
- manual set, 16
- measurement application
  - updating, 636
- Measurement Guides and Programming Examples Guides on CD-ROM, 16
- message URL
  - [www.keysight.com/find/assist](http://www.keysight.com/find/assist), 41
- messages
  - error, 73
- messages, warning, 74
- midplane
  - see A7 midplane
- midplane assembly
  - removal, 518
- midplane bracket
  - part number, 366
- motherboard
  - see A8 motherboard
- mouse
  - USB, 25

## N

- N7814A
  - see calibration application software

## O

- operating system, 14
  - problems, 59
- Option BBA, 552
  - description, 333
- Option BBA removal
  - BBA removal, 549

- options, 16
- original instrument packing, 43
- other instrument packing, 44
- outer case (Option PRC), removal, 442
- outer case, removal, 440
- overview, MXA signal analyzer, 14

## P

- packaging, 43
- parts
  - replaceable, 366
- PCI enumeration error, 58
- performance verification tests
  - equipment, 26
  - required test equipment, 26
  - test equipment, 26
- performance verification tests vs functional tests, 599
- post-repair procedures, 562
- power amplifiers, 17
- power on LED, 53
- power splitters, 18
- power supply
  - see A6 power supply, 366
- preamplifiers, 17
- preload measurement
  - applications, 47
- preselector
  - see A12 YTF
- probes
  - AC and DC, 17

## R

- rear panel
  - removal, 486
- rear panel display output, 59
- recovery process, 312
- reference assembly
  - see A16 reference assembly
- reference bracket
  - part number, 366
  - removal, 445
- remove
  - see individual assemblies
- repairs
  - see post-repair procedures
- replace
  - see individual assemblies
- replaceable parts, 366
- required equipment, 26
- required test equipment
  - adjustments, 26
  - performance verification tests, 26
  - troubleshooting, 26
- return instrument for service, 43
- RF area components, 447
- RF Flatness menu description, 354
- RF input connector
  - part number, 366
  - removal, 529
- RF limiters, 18
- RF path block diagram, 336
- RF section
  - description, 138

- RPG knob
  - part number, 366

## S

- Safety Information, 437
- Sales and Service offices, 39
- second harmonic distortion test, 609
- separate analog IF assembly and digital IF assembly, 514
- serial number, 42
- service
  - equipment, 23
  - returning your instrument, 43
  - tools, 438
- service menus, 347
- service strategy, 14
- signal level verification, 70
- Snapshot Alignments menu
  - description, 354
- software licensing, 637
- specifications, 46
- Specifications Guide on CD-ROM, 16
- splash screen, 48, 57, 58
- splitters, 18
- spread spectrum, 578, 583, 587, 588
- standby LED, 51
- static safety accessories, 18
- static-safe workstation, 21
- status messages, 75
- storage device
  - USB, 25
- support URL, 39
- support web site, 39
- synthesizer
  - see A14 L.O. synthesizer assembly

## T

- test equipment
  - adjustments, 26
  - performance verification tests, 26
  - post-repair, 561
  - troubleshooting, 26
- tests. See functional tests
- timebase key description, 353
- top brace
  - part number, 366
  - removal, 445
- transient limiter, 18
- troubleshooting
  - basics, 46
  - before you start, 19
  - equipment needed, 26
  - high band, 174
  - low band, 146
  - see individual assemblies

## U

- updating firmware, 636
- updating measurement
  - applications, 636
- upgrades, 15

## Index

URL, [39](#), [46](#)  
USB keyboard and mouse, [25](#)  
USB storage device, [25](#)  
User's/Programmers Reference  
Guides on CD-ROM, [16](#)

## V

video controller, [63](#)  
video signal path integrity, [63](#)

## W

warning messages, [74](#)  
warnings and cautions, [19](#)  
web site URL, [46](#)  
wide band analog IF  
    see A25 Wide Band Analog IF  
    assembly  
wide band digital IF  
    see A26 Wide Band Digital IF  
    assembly

## Y

yellow LED, [48](#), [51](#)  
yig filter  
    see A12 YTF  
YTF  
    see A12 YTF